



*Assembly Guide & Warranty Card Included

FORCE

LEG EXTENSION/LEG CURL



OWNER'S MANUAL

Model # SD1000

Revision 071621

FORCE STRENGTH OWNERS MANUAL

IMPORTANT:

All Products shown are prototype. Actual product delivered may vary.
Product specifications, features & software are subject to change without notice.
For the most up to date owner's manual please visit www.truefitness.com.
For documents in additional languages please visit www.truefitness.com/resources/document-library/

IMPORTANTE:

Todos los productos mostrados son prototipos. La realidad el producto suministrado puede diferir.
Especificaciones de productos, características y software están sujetas a cambios sin previo aviso.
Para la más actualizada de este manual del propietario, por favor visite www.truefitness.com
Para los documentos en otros idiomas, por favor visite www.truefitness.com/resources/document-library/

IMPORTANT:

Tous les produits présentés sont prototype. Le produit réel livré peut varier.
Spécifications du produit, caractéristiques et logiciels sont sujettes à modification sans préavis.
Pour la plus à jour le manuel du propriétaire s'il vous plaît visitez www.truefitness.com.
Pour documents dans des langues supplémentaires, veuillez www.truefitness.com/resources/document-library/ de visite

重要提示 :

显示所有产品的原型。实际交付的产品可能有所不同
产品规格，功能和软件如有更改，恕不另行通知
迄今为止对于大多数的使用说明书，请访问www.truefitness.com
对于其他语言的文档，请访问www.truefitness.com/resources/document-library/

هام:

جميع المنتجات المعروضة هي النموذج. قد تختلف المنتج الفعلي تسليمها.
مواصفات المنتج، والميزات والبرامج قابلة للتغيير دون إشعار.
www.truefitness.com لمعظم ما يصل حتى الآن دليل المالك يرجى زيارة
www.truefitness.com/resources/document-library/ للمستندات في لغات إضافية، يرجى زيارة

WICHTIG:

Alle hier gezeigten Produkte sind Prototypen. Das tatsächliche Produkt ausgeliefert wird, kann variieren.
Produkt-Spezifikationen, Funktionen und Software können sich ohne vorherige Ankündigung ändern.
In den meisten Fällen bis zu Bedienungsanleitung Bisher besuchen Sie bitte www.truefitness.com.
Für Dokumente in weiteren Sprachen finden Sie unter www.truefitness.com/resources/document-library/

BELANGRIJK:

Alle getoonde producten zijn prototype. Daadwerkelijke product geleverd kan verschillen.
Product specificaties, eigenschappen & software zijn onderhevig aan verandering zonder kennisgeving.
Voor de meest actuele handleiding van de eigenaar kunt u terecht www.truefitness.com.
Voor documenten in andere talen kunt u terecht op www.truefitness.com/resources/document-library/

ВАЖНО:

Все товары указаны прототипа. Фактический продукт, поставляемый могут отличаться.
Технические характеристики, особенности и программного обеспечения могут быть изменены без предварительного уведомления.
Для получения самой последней на сегодняшний день руководство по эксплуатации пожалуйста, посетите www.truefitness.com.
Для документов на другие языки, пожалуйста, посетите www.truefitness.com/resources/document-library/

FORCE STRENGTH OWNERS MANUAL

Frank Trulaske began TRUE Fitness over thirty-five year ago with the simple philosophy of delivering superior fitness products, service and support. Today, TRUE is the global leader in premium fitness equipment for the commercial and residential markets. Our goal is to be the leader in technology, innovation, performance, safety and style. TRUE has received many awards for its product over the years and remains the benchmark for the industry. Fitness facilities and consumers invest in TRUE products for their durable commercial platforms used in all its products, both commercial and residential alike.

The proud manufacturing tradition of quality and the culture of innovation at TRUE have given rise to a full line of extraordinary cardio and strength equipment. As a result, people all over the world are benefiting from the TRUE experience. Innovation across the full product line has made TRUE successful and is a trademark of the TRUE heritage. TRUE's patented Heart Rate Control technology is just one of the remarkable ways we deliver simple and superior performance every user can enjoy, and most importantly, use to achieve personal health and fitness goals.

At the heart of our success is the relentless and systematic life testing of both our products and their components. We have dedicated employees who understand our philosophy is to deliver the best products in the world.

Our goal is to deliver the world's best premium equipment for our customers' health and fitness solutions.

FORCE STRENGTH OWNERS MANUAL

TABLE OF CONTENTS:

Chapter 1: Safety Instructions

Safety Instructions.....	1
Space Requirements.....	3
Working Dimensions.....	3
Warning Decals.....	4
Proper Training Position.....	5

Chapter 2: Assembly Instructions

Pre-Assembly Check List.....	7
Assembly Steps	10

Chapter 3: Product Overview

Product Overview.....	36
-----------------------	----

Chapter 4: Care & Maintenance

Care & Maintenance.....	37
Daily Inspection & Maintenance.....	37
Weekly Inspection & Maintenance.....	37
Other Scheduled Preventive Maintenance.....	38
Cleaning the Equipment.....	38
Cable Inspection & Maintenance.....	39

Chapter 5: Customer Service

Contacting Service.....	41
Contacting Sales.....	41
Reporting Freight Claims or Parts Damage.....	42



Chapter 6: Additional Information

Warranty Registration.....	43
----------------------------	----











CHAPTER 1: SAFETY INSTRUCTIONS

IMPORTANT SAFETY INSTRUCTIONS SAVE THESE SAFETY INSTRUCTIONS

Force series strength equipment is intended for a commercial or institutional setting. This owner's manual should be accessible to all personal trainers, staff members, and members.

-  WARNING: All EXERCISERS MUST READ ALL INSTRUCTIONS BEFORE USING STRENGTH EQUIPMENT.
-  WARNING: Over-exercising may result in serious injury or death. If you feel faint, stop exercising immediately.
-  WARNING: Equipment should be immediately taken out of use if it fails to work properly

TRUE STRONGLY recommends seeing a physician for a complete medical exam before undertaking an exercise program, particularly if the user has a family history of high blood pressure or heart disease, is over the age of 45, smokes, has high cholesterol, is obese or has not exercised regularly in the past year. Additionally, TRUE recommends consulting a fitness professional on the correct use of this product. If at any time while exercising the user experiences faintness, dizziness, pain or shortness of breath, he or she must stop immediately.

-  WARNING: To reduce the risk of injury, facility personnel should inspect the equipment daily for potential issue, such as loose hardware, worn or frayed cables, cracked pulleys or welds.
-  WARNING: To reduce the risk of injury, facility personnel should provide direct supervision of the use of strength equipment and provide knowledge about the safe operation of the equipment to users if they recognize potential issues.
-  WARNING: Do not move the equipment by lifting the moving arms, plates or adjustment handles/knobs.
-  WARNING: This product contains chemicals known to the state of California to cause cancer and birth defects or other reproductive harm.
*for additional information visit <http://oehha.ca.gov/prop65>
-  WARNING: Keep equipment stable on flat ground. True Fitness recommends for all strength equipment to be bolted down to the floor to avoid toppling during improper use.
-  WARNING: Replace warning labels that may be worn, damaged or missing.
-  WARNING: Replace any non-working or damaged components; remove the unit from service until repair is performed.
-  WARNING: To reduce the risk of injury, follow these instructions:
 - Do not attempt to free any jammed equipment without appropriate assistance.
 - Do not use strength equipment if the top plate or weight stack is pinned in a raised position.
 - Do not use strength equipment if the weight stack selector pin is bent or damaged.
 - Do not place the equipment in a wet location or outdoors.
 - Do not use equipment if dropped or otherwise damaged.
 - Do not attempt to lift more weight than you can control safely.
-  WARNING: Do not operate the equipment while being covered with a blanket, plastic, or anything that restricts operation.
-  WARNING: Risk of personal injury-crushing hazard when strength equipment is in operation - Keep feet, hands, and fingers away from moving parts.

CHAPTER 1: SAFETY INSTRUCTIONS

CAUTION:

- Health related injuries may result from incorrect or excessive use of exercise equipment.
- Take care when getting on or off strength equipment.
- If you do not understand how to use/operate a piece of equipment seek assistance from facility staff or trainer to demonstrate safe and proper use.
- Any changes or modifications to this equipment could void the product warranty.
- Always follow all posted safety instructions and warnings for proper operation.
- Close supervision is necessary when used near or disabled persons or children under the age of 15.
- Do not use this product outdoors, near water, while wet, or in areas of high humidity including extreme temperature changes.
- Never insert objects into any openings in this product. If an object should drop inside, carefully retrieve it. If the item cannot be reached, contact TRUE Customer Service.
- Never place liquids of any type directly on the unit except in the accessory tray or bottle holders. Containers with lids are recommended.
- Wear shoes with rubber or high traction soles. Do not use shoes with heels, leather soles, cleats or spikes. Make sure no stones are embedded in the soles. Do not use this product in bare feet. Keep all loose clothing, shoelaces and towels away from moving parts.
- Do not reach into or underneath the unit, or tip it on its side during operation.
- Use correct ergonomic positioning while operating strength equipment.
- Do not allow animals on or near the equipment while in operation.
- Do not exceed maximum user weight of 300 lbs. (136 kg).
- Avoid exiting strength equipment if any part is still in motion.
- Do not use if you have a cold or fever.
- When using this exercise machine, basic precautions should always be followed.
- Use this equipment only for its intended use as described in this manual.
- Do not use attachments not recommended by the manufacturer.
- Allow only trained personnel to service this equipment.
- Avoid the possibility of bystanders being struck or caught between moving parts by making sure that they are out of reach while equipment is in motion.
- Allow only one person at a time on the equipment while it's in operation.
- It is the sole responsibility of the owner/operator to ensure regular and scheduled maintenance is performed.
- This appliance can be used by children aged from 8 years and above and persons with reduced physical, sensory or mental capabilities or lack of experience and knowledge if they have been given supervision or instruction concerning use of the appliance in a safe way and understand the hazards involved.
- Children shall not play with the appliance.
- Cleaning and user maintenance shall not be made by children without supervision.
- Always check the equipment before using it. If you spot a potential problem, contact the facility staff immediately.
- Do not drop or slam the weight stack while exercising.
- Do not use equipment or attempt to fix if broken or jammed.
- Do not use the equipment for support during stretching.
- Do not use any other means other than the one provided to incrementally increase the weight resistance.
- Always check that the weight selector pin is fully inserted into the weight stack before using.

CHAPTER 1: SAFETY INSTRUCTIONS

SPACE REQUIREMENTS:

TRUE's recommendation is to leave a 40" (1.0m) safety zone on all sides of the unit.

Additionally for Functional Trainers there should be enough room left for full extension of all cable in all directions. (See Fig 1)

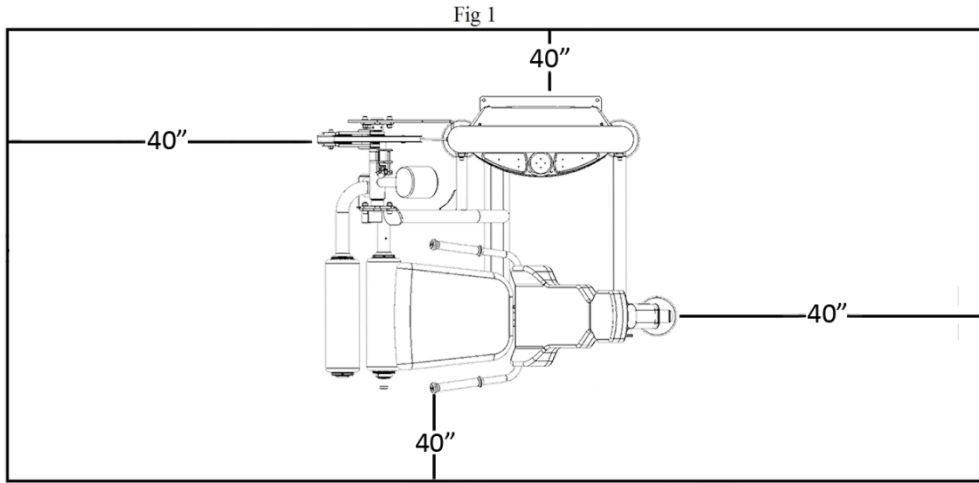

WORKING DIMENSIONS:

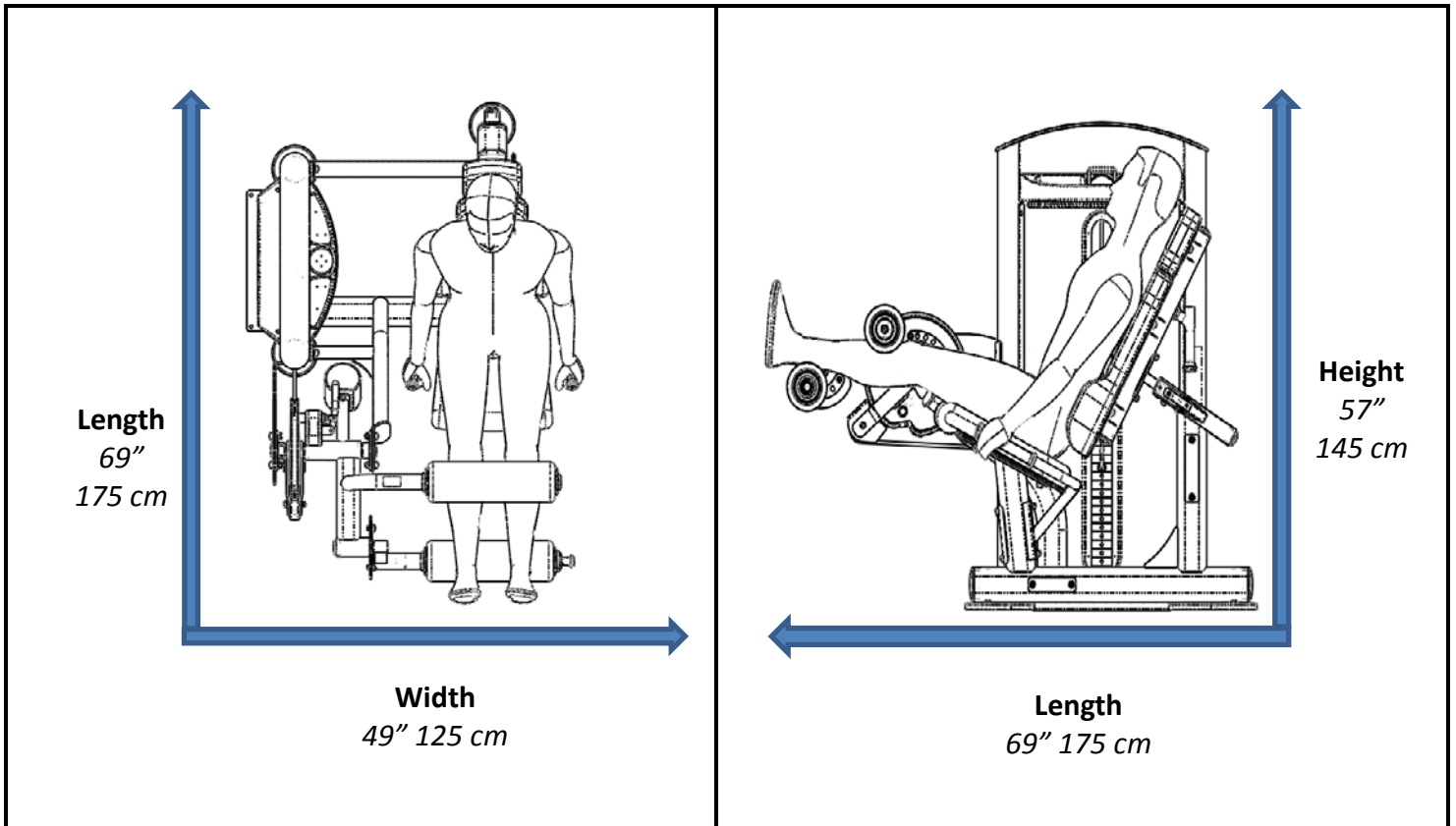

CHAPTER 1: SAFETY INSTRUCTIONS

WARNING DECALS:

⚠ WARNING: Replace warning labels that may be worn, damaged or missing.

*To replace any worn or missing warning decals contact TRUE FITNESS by one of the following: www.truefitness.com or contact customer service at 800-883-8783.

FORCE Weight Stack Labels: SWLAB175 (175 lb. Regular Weight Stack) and SWLAB255 (255 lb. Heavy Weight Stack).

Part Number: 7SM0045MD

COMMERCIAL MAINTENANCE SCHEDULE				
	DAILY	WEEKLY	MONTHLY	6 MONTHS
INSPECT: Cables for wear, tension and proper connection	X			
INSPECT: All nuts and bolts and tighten if needed		X		
INSPECT: All anti-slip surfaces and replace as needed		X		
INSPECT: All adjustment pins, weight stack pins, set screws, gas shocks, snap links, pulleys	X			
INSPECT: All accessory bars and handles		X		
INSPECT: All safety and instructional decals	X			
INSPECT: All weight stack shields	X			
CLEAN: Guide rods and lubricate with a teflon lubricant			X	
CLEAN: Upholstery	X			
LUBRICATE: Pivot bearings and linear bearings				X

⚠ WARNING!

Replace damaged or worn parts with genuine True Fitness replacement parts. Failure to do so will void warranty and could result in serious injury or death. There is a risk assumed by individuals who use this type of equipment. To minimize the risk, always follow these rules.

1. Consult your physician before beginning any exercise program to insure physical readiness.
2. Never attempt to exceed your personal performance capabilities.
3. Stop exercising if you experience pain or dizziness and seek medical attention.
4. Read and understand the provided instructional information before using this equipment.
5. Inspect equipment before each use. Do not use equipment if any parts show wear or damage until those parts have been replaced by an authorized service provider. Failure to replace worn or damaged parts may result in injury or additional damage to the machine.
6. Follow a routine maintenance schedule as communicated in the owner's manual.
7. Keep bystanders clear of all moving parts to prevent injury.
8. If the equipment becomes inoperable for any reason, prevent it from being operated until an authorized service provider can repair it.
9. Children should not be allowed to use this equipment without adult supervision.
10. To ensure equipment cannot be tipped, bolt equipment to the exercise floor as communicated in the owner's manual.
11. Contact your authorized dealer or service provider if you have any questions on the proper use or maintenance of this equipment.

ASTM F1749 Part Number: 7SM0045MD

⚠ WARNING!

PINCH POINTS



ASTM F1749 Part Number: 7SD0301

⚠ CAUTION!

MOVING PARTS



ASTM F1749 Part Number: 7SD0398

⚠ WARNING!

SERIOUS INJURY CAN OCCUR ON THIS EQUIPMENT IF THE PIN IS NOT COMPLETELY INSERTED BEFORE USE.

ASTM F1749 Part Number: 7SD0399

TRUE
FITNESS TECHNOLOGY, INC.
865 HOFF ROAD, OFALLON, MISSOURI 63366 USA

Model No.
SD1000

Serial No. / Date Code
15-SD001234J

MADE IN CHINA

⚠ WARNING!

SERIOUS INJURY CAN OCCUR ON THIS EQUIPMENT IF THE PIN IS NOT COMPLETELY INSERTED BEFORE USE.

MAXIMUM HEIGHT UNDER NUT TO BOLT HEAD.
MAKE SURE LOCKING NUT IS TIGHT.

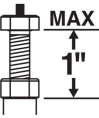

SERIOUS INJURY CAN OCCUR ON THIS EQUIPMENT IF THE CABLES AND THEIR ATTACHMENT POINTS ARE NOT INSPECTED OFTEN. REPLACE AT FIRST SIGNS OF WEAR.

©2012 TRUE Part Number: 7SM0045MD

LEG CURL / LEG EXTENSION

FORCE SERIES • SD1000

TARGET MUSCLES: HAMSTRINGS

1. Select appropriate weight.
2. Adjust back pad so knees are aligned with pivot point.
3. Adjust rotation arm and ankle pad to desired starting position.
4. Place feet over outer pad and rotate to a 90 degree leg position.
5. Perform the exercise in a slow controlled manner.

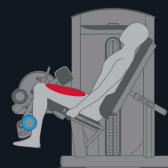

TARGET MUSCLES: QUADRICEPS

1. Select appropriate weight.
2. Adjust back pad so knees are aligned with pivot point.
3. Adjust rotation arm and ankle pad to desired starting position.
4. Place feet behind lower pad and rotate to an extended leg position.
5. Perform the exercise in a slow controlled manner.



LBL-PR-SD00BK

CHAPTER 1: SAFETY INSTRUCTIONS

PROPER TRAINING POSITION:

Target Muscles: Hamstrings

- A. Select appropriate weight.
- B. Adjust back pad so knees are aligned with red aluminum cap.
- C. Adjust rotation arm and ankle pad to desired starting position.
- D. Place feet over outer pad and rotate leg 90 degrees.
- E. Perform the exercise in a slow, controlled manner.

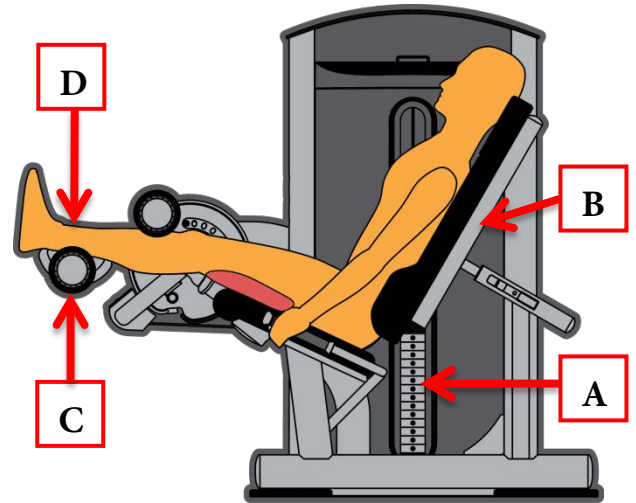

Target Muscles: Quadriceps

- A. Select appropriate weight.
- B. Adjust back pad so knees are aligned with red aluminum cap.
- C. Adjust rotation arm and ankle pad to desired starting position.
- D. Place feet behind lower pad and extend leg to desired position.
- E. Perform the exercise in a slow, controlled manner.

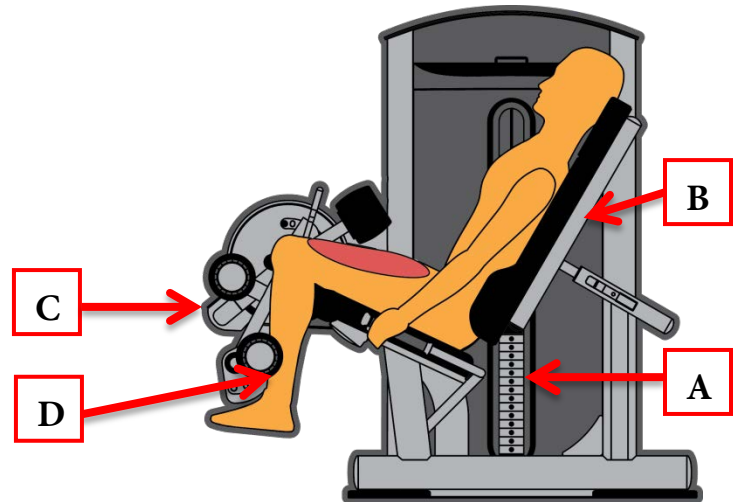

CHAPTER 2: ASSEMBLY GUIDE

IMPORTANT SAFETY INSTRUCTIONS

- Read all instructions before using the equipment. These instructions are written to ensure the user's safety and to protect the unit.
- Do not allow children on or near the equipment.
- Use the equipment only for its intended purpose as described in this guide.
- Do not use accessory attachments that are not recommended by the manufacturer as they may cause injuries or damage the machine.
- Wear proper exercise clothing and shoes for a workout.
- Use caution when entering and exiting the machine.
- Never attempt to exceed your personal performance capabilities.
- If you feel any pain or become dizzy, stop your workout immediately and seek medical attention.
- Never attempt to operate the unit if you suspect that it is not working properly or appears damaged.
- Only allow authorized TRUE service providers to repair the machine.
- Never drop or insert anything into any opening in the equipment.
- Always inspect the unit and its cables before each use. Make sure that all fasteners and cables are secure and in good working condition.
- Frayed or worn cables can be dangerous and may cause injury. Periodically check these cables for any indication of wear.
- Keep hands, limbs, loose clothing and hair well out of the way of moving parts.
- Never attempt to use this machine if it is not on stable, level and dry surface.

Personal Safety During Assembly:

- Read each step in the assembly instructions and follow the steps in sequence. Do not skip ahead. If you skip ahead, you may learn later that you have to disassemble components and that you may have damaged the equipment.
- Assemble and operate the equipment on a solid, level and dry surface. Locate the unit a few feet from walls in an open area to provide easy access.
- Before beginning assembly please take the time to read instructions thoroughly.
- The assembly of this product requires two people to ensure that it is safely and properly assembled.
- Please use the various lists in this manual to make sure that all parts have been included in your shipment.
- When ordering, use part number and description from the lists. Use only True Fitness replacement part when servicing. Failure to do so will void your warranty and could result in personal injury or damage your machine.
- This equipment is designed to provide the smoothest, most effective exercise motion possible. After assembly, you should check all functions to ensure correct operation. If you experience problems, first recheck the assembly instructions to locate any possible errors made during assembly. If you are unable to correct the problem, call your authorized dealer. Be sure to have your serial number and this manual when calling. When all parts have been accounted for, continue on.

CHAPTER 2: ASSEMBLY GUIDE

PRE-ASSEMBLY CHECKLIST:

Box One Contents:

Item No.	Description	QTY.
1	Weight Stack Frame	1
2	Cam Support Bracket	1
3	Outer Top Shroud Support	1
4	Lower Shroud Supports	2
5	Roller Pads	2
6	Seat Pad	1
7	Back Pad	1
8	Head Pad	1
9	Inner Shroud Supports	2
10	Right Outer Shroud Support	1
11	Left Outer Shroud Support	1
12	Stability Foot	1
13	Guide Rods	2
14	Top Plate & Guide Rod	1

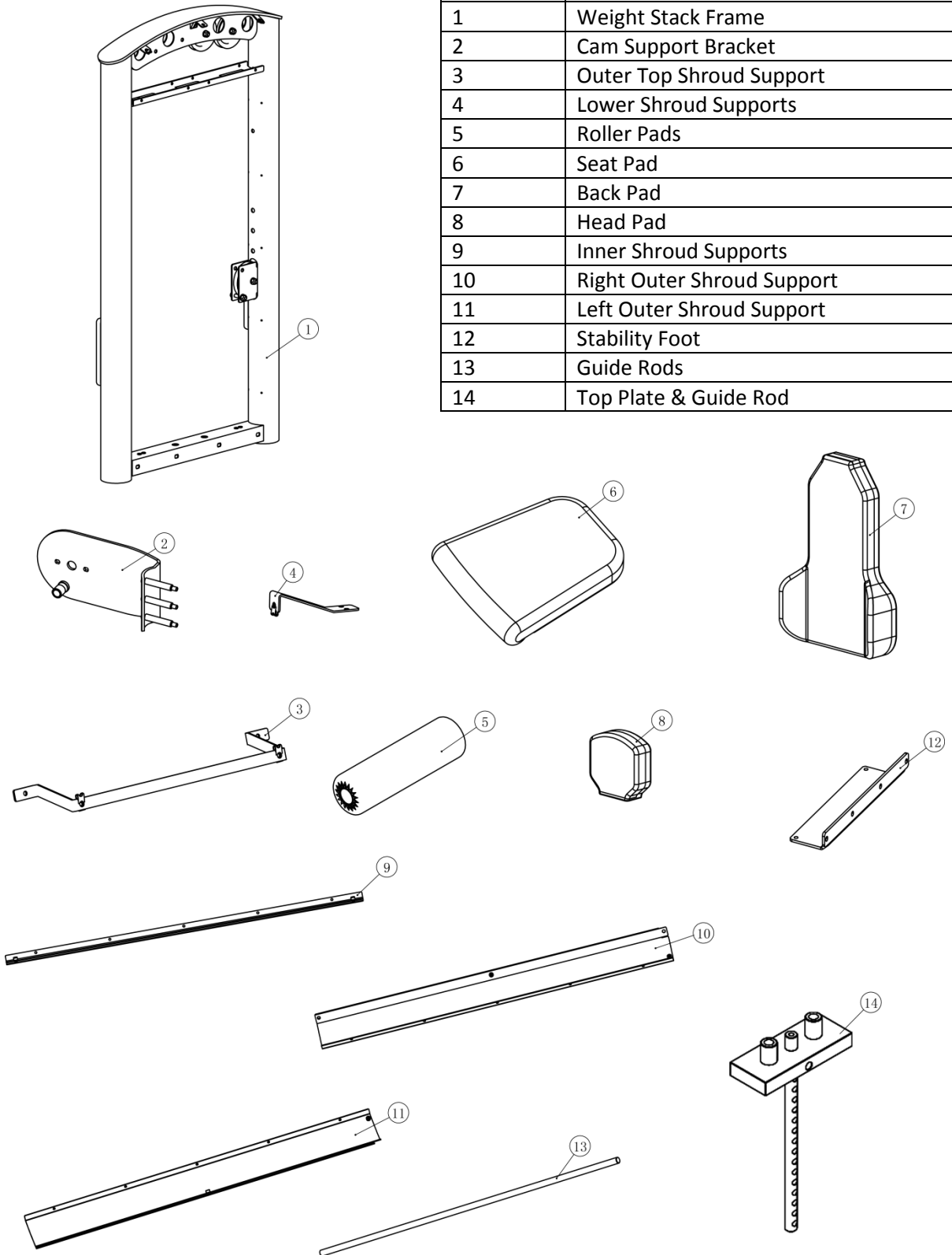

CHAPTER 2: ASSEMBLY GUIDE

PRE-ASSEMBLY CHECKLIST:

Box Two Contents:

Item No.	Description	QTY.
1	Ankle Support Arm	1
2	Seat Frame	1
3	Movement Arm	1
4	Back Pad Frame	1
5	Directional Pulley	1
6	Cam	1
7	Handle Bar	1
8	Base/Pivot Support	1
9	Frame Cross Support	1
10	Cable Assembly	1
11	Cam Pivot Rod	1
12	Counter-Weight	1
13	Seat Pad Support	1
14	Cam Pivot Bearing	2
15	Adjustable Foot Plate	4

*Hardware Pack (not pictured) is included in box two as well.

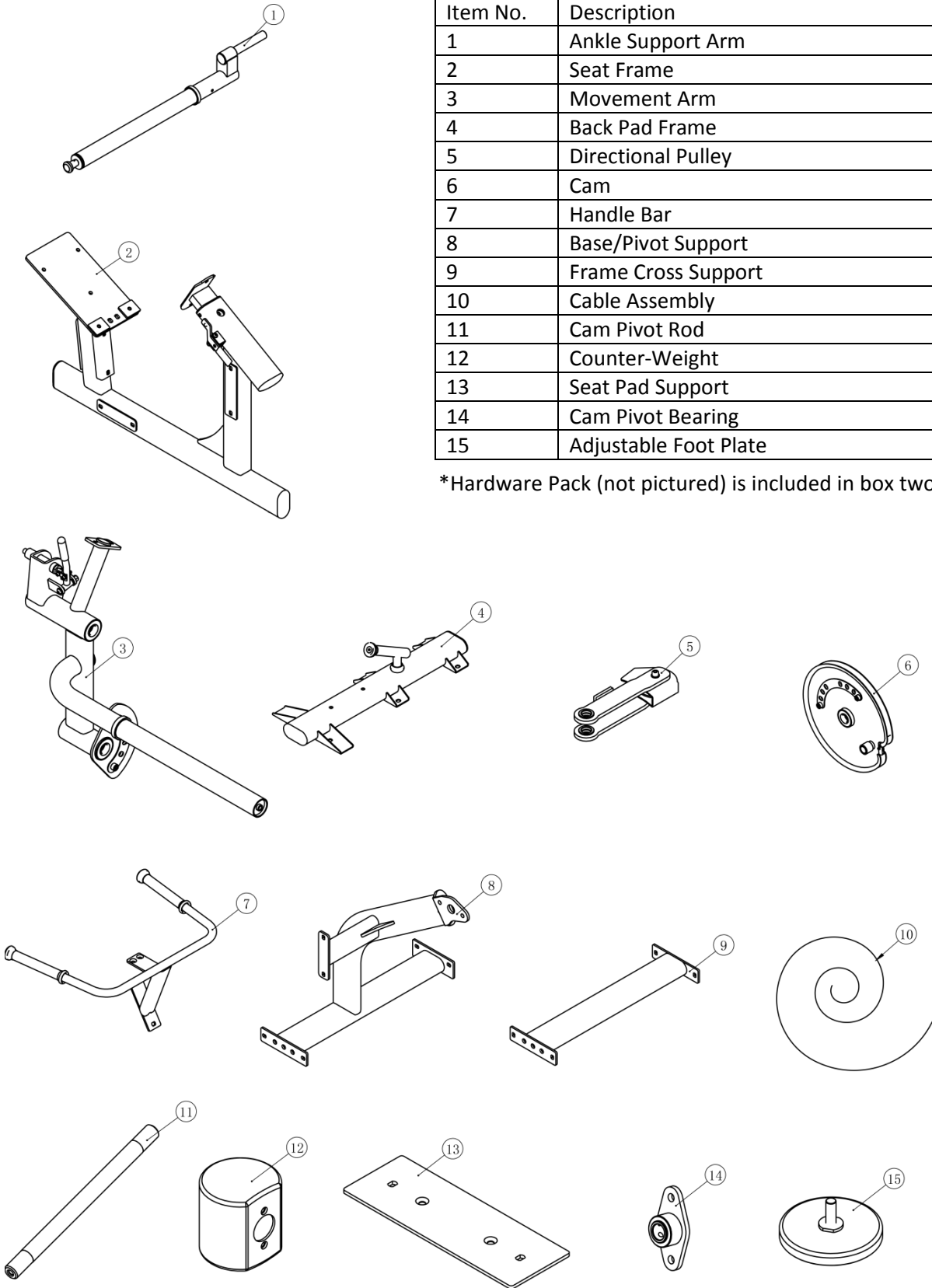

CHAPTER 2: ASSEMBLY GUIDE

PRE-ASSEMBLY CHECKLIST:

Box Three Contents:

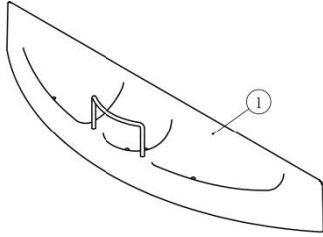

Item No.	Description	QTY.
1	Accessory Tray	1
2	Placard Frame	1
3	Outer Shroud Cap	1
4	Rear Shroud	1
5	Front Shroud	1

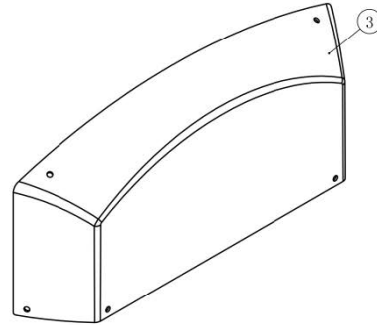
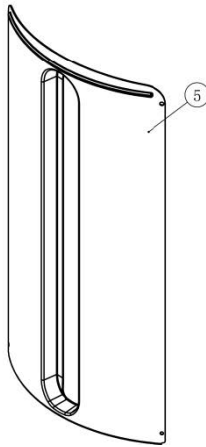
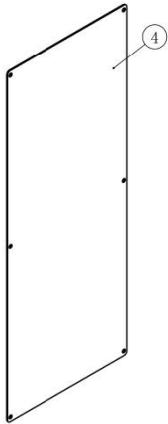
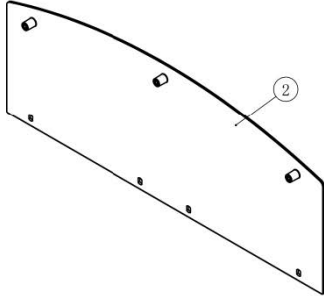

Weight Plate Cartons:

Weight Plates are packaged (4) per box. The shipment should contain (4) Boxes of weight plates for a total of 16 weight plates. The weight plates are available in two different sizes: 10 lbs. and 15 lbs. The 10 lbs. plates are used for the standard weight stack and the 15 lbs. plates are used for the heavy weight stack. Ensure the correct weight stack is being installed on this machine.

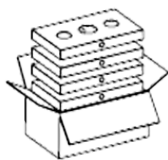
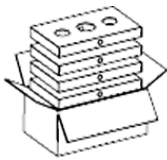

(4) x 10lb. Weight Plates
10 LB Weight Plate Box

OR

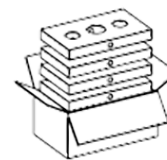
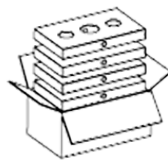

15 LB Weight Plate Box
(4) x 15 lb. Weight plates

CHAPTER 2: ASSEMBLY GUIDE

UNIT ASSEMBLY STEPS:

STEP 1 Frame Assembly:

1. Attach 2 Adjustable Foot Plates to the bottom of the Upright Assembly.
2. Secure the Base/Pivot Support and Stability Foot to the Upright Assembly as shown.

ITEM	Description	Qty
46	Lock Washer #10	2
49	Flat Washer 11x20x2	10
51	M10 Nylon Lock Nut	4
59	M10x20 Socket Head Cap Screw	2
63	M10x100 Socket Head Cap Screw	4

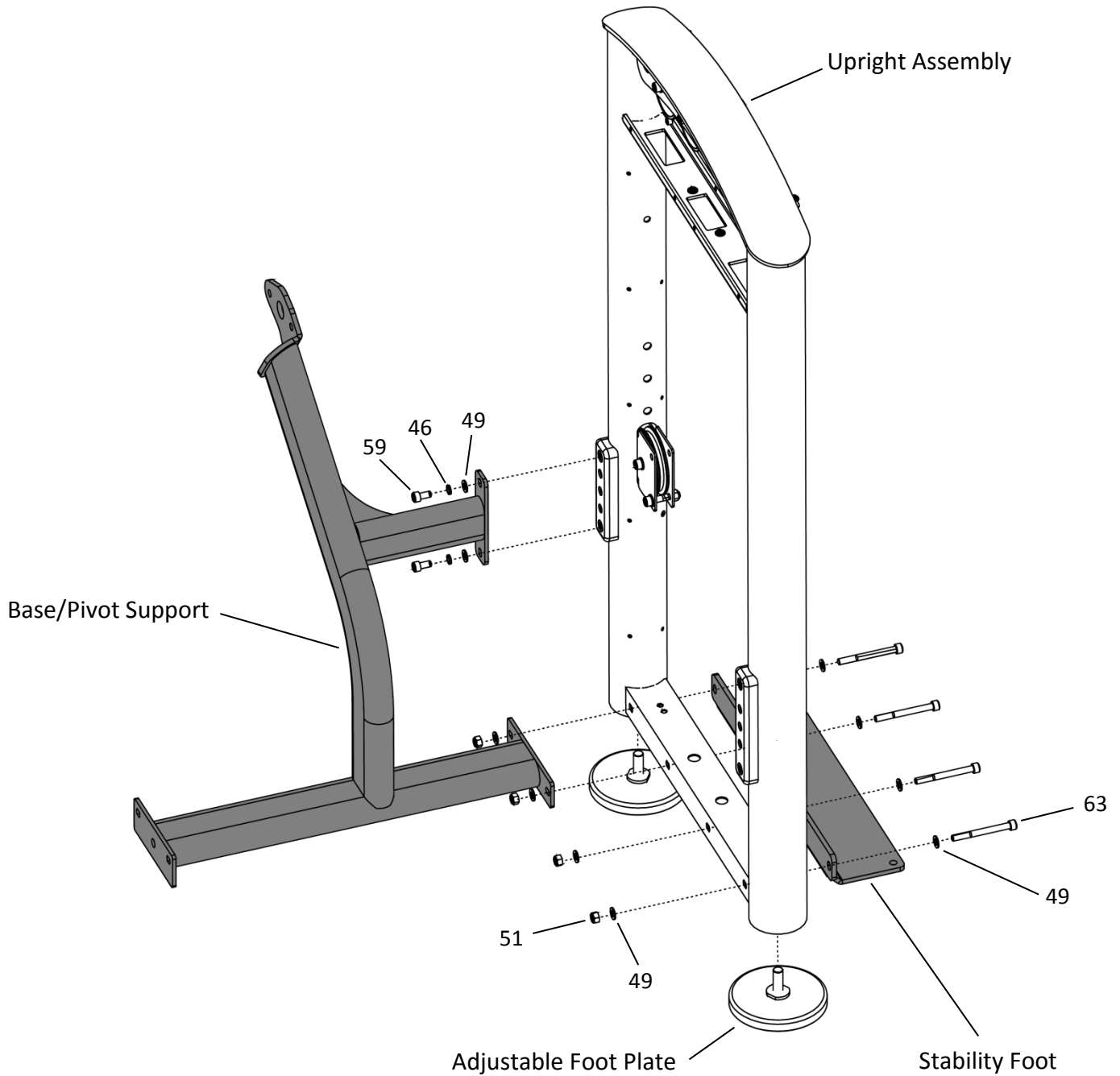

CHAPTER 2: ASSEMBLY GUIDE

UNIT ASSEMBLY STEPS (CONTINUED):

STEP 2 Seat Frame Assembly:

1. Attach 2 adjustable foot plates to the bottom of the Seat Frame.
2. Secure the Seat Frame to the Base/Pivot Support as shown below.

ITEM	Description	Qty
49	Flat Washer 11x20x2	4
51	M10 Nylon Lock Nut	2
62	M10x75 Socket Head Cap Screw	2

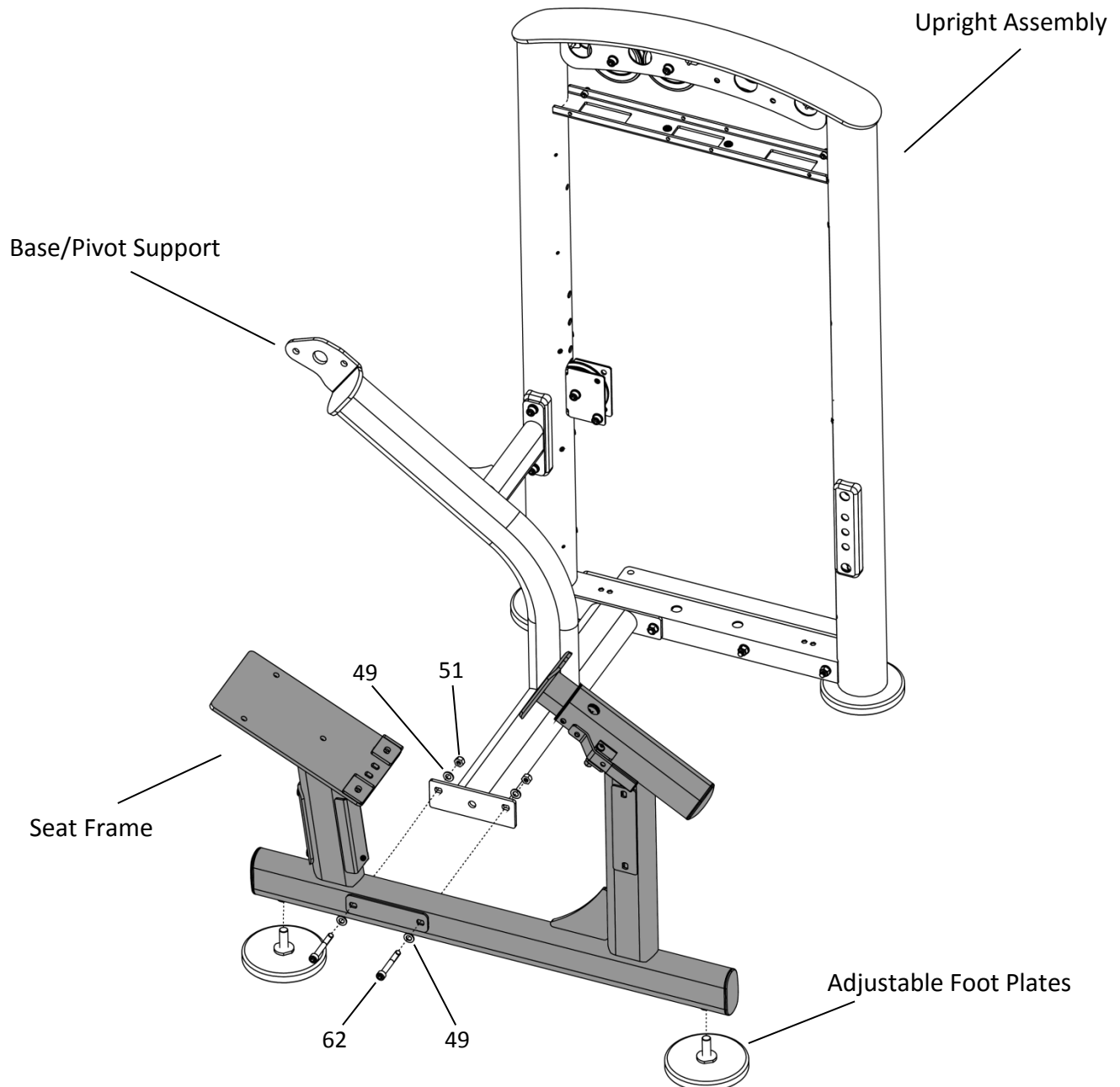

CHAPTER 2: ASSEMBLY GUIDE

UNIT ASSEMBLY STEPS (CONTINUED):

STEP 3 Frame Cross Support:

1. Install the Frame Cross Support as shown.

ITEM	Description	Qty
46	Lock Washer #10	2
49	Flat Washer 11x20x2	6
51	M10 Nylon Lock Nut	2
59	M10x20 Socket Head Cap Screw	2
62	M10x75 Socket Head Cap Screw	2

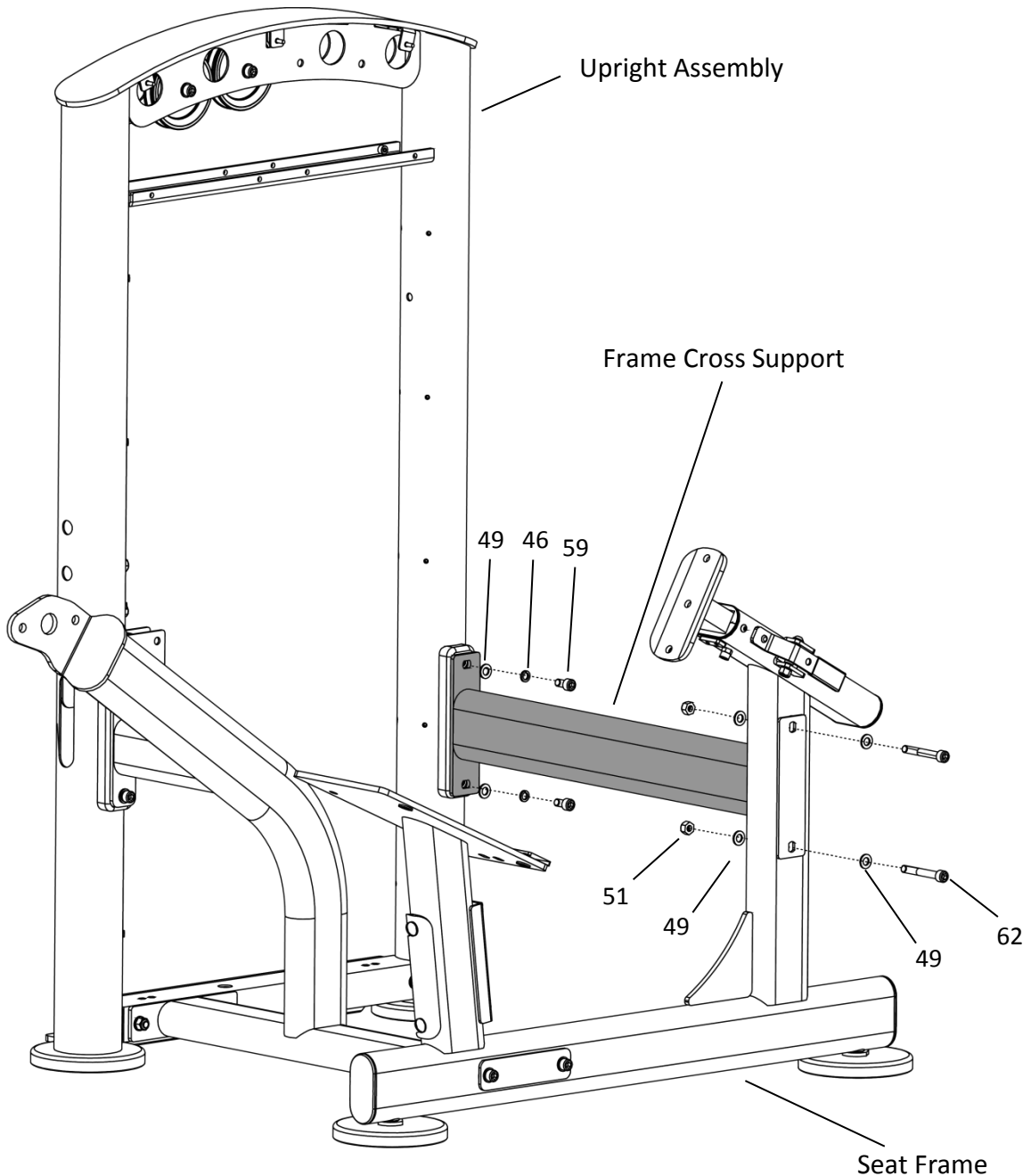

CHAPTER 2: ASSEMBLY GUIDE

UNIT ASSEMBLY STEPS (CONTINUED):

STEP 4 Cam Support Bracket:

1. Install the Cam Support Bracket as shown.

ITEM	Description	Qty
50	Flat Washer 13x24x2.5	3
52	M12 Nylon Lock Nut	3

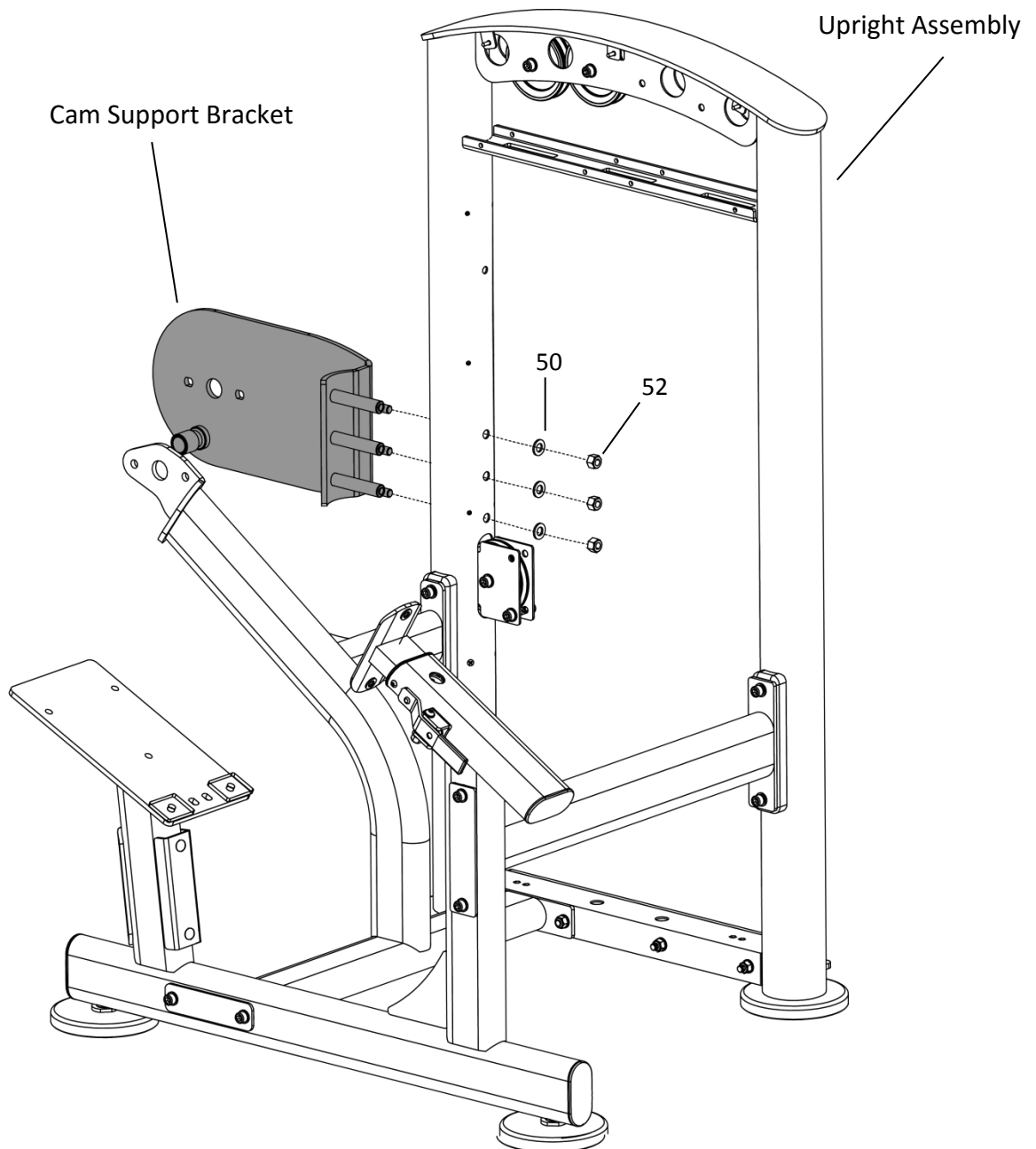

CHAPTER 2: ASSEMBLY GUIDE

UNIT ASSEMBLY STEPS (CONTINUED):

STEP 5 Lower Shroud Supports:

1. Install the Lower Shroud Supports as shown.

ITEM	Description	Qty
44	#6 Lock Washer	4
47	Flat Washer 6.6x12x1.6	4
56	M6x20 Button Head Cap Screw	4

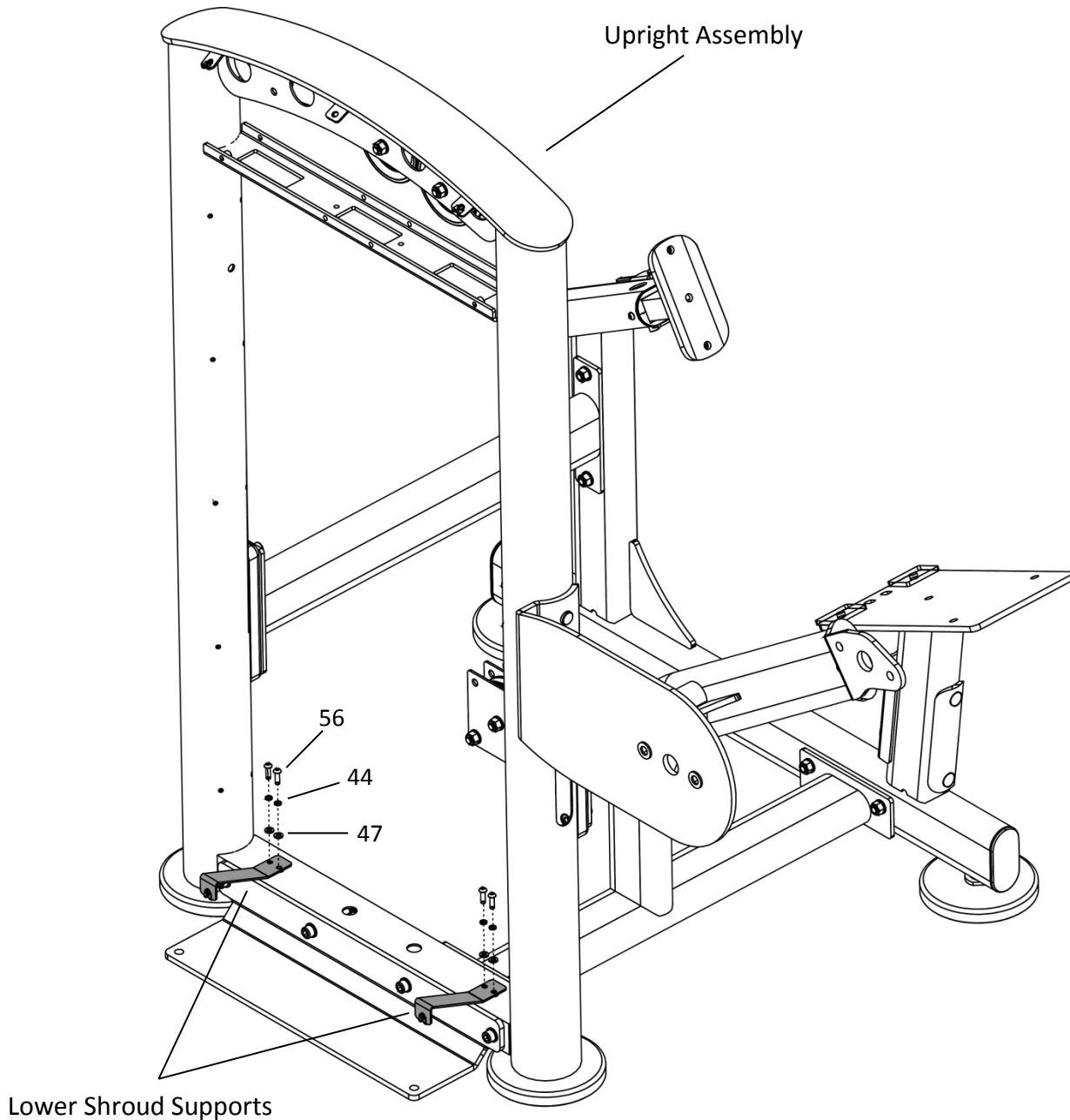

CHAPTER 2: ASSEMBLY GUIDE

UNIT ASSEMBLY STEPS (CONTINUED):

STEP 6 Inner Shroud Supports:

1. Install the Inner Shroud Supports as shown.

ITEM	Description	Qty
53	M5x16 Phillips-Head Screw	10

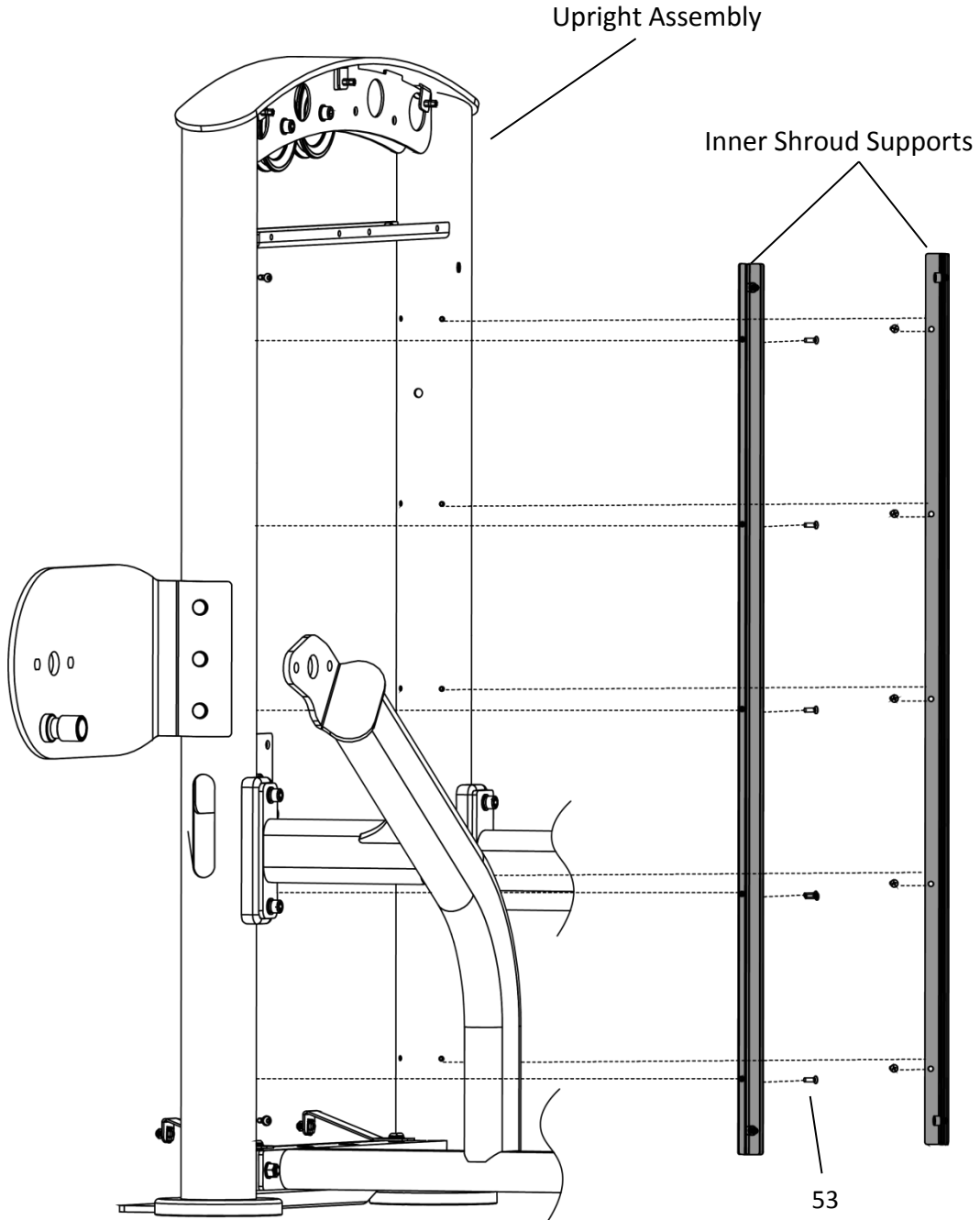

CHAPTER 2: ASSEMBLY GUIDE

UNIT ASSEMBLY STEPS (CONTINUED):

STEP 7 Cam Assembly:

1. Using the diagram below, construct the Cam Assembly.

ITEM	Description	Qty
42	M8x8 Socket Head Set Screw	4

2. Tighten the Socket Set Screws on each Cam Pivot Bearing.

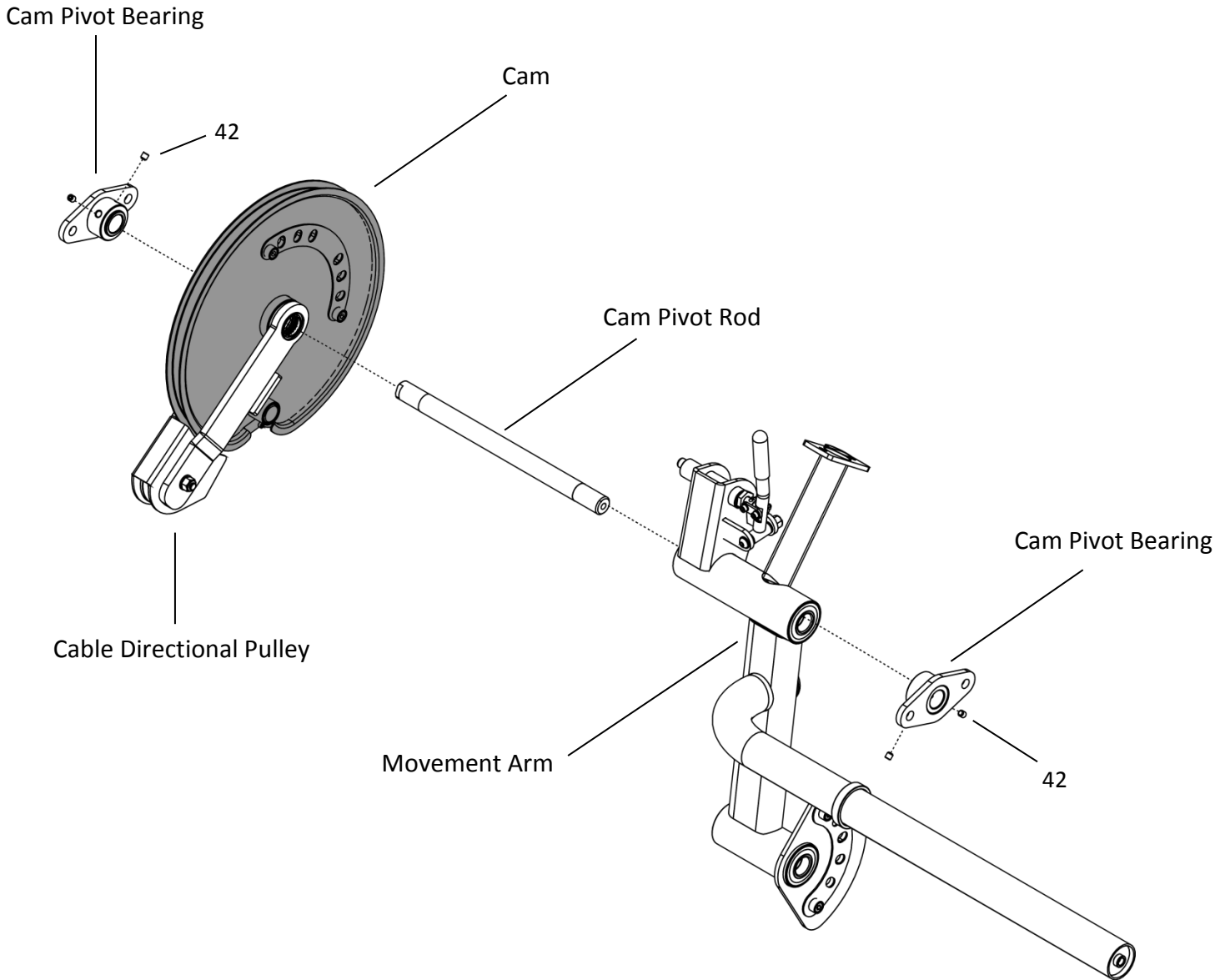

CHAPTER 2: ASSEMBLY GUIDE

UNIT ASSEMBLY STEPS (CONTINUED):

STEP 8 Install Cam Assembly:

1. Install the Cam Assembly as shown.

*Note: Ensure the red aluminum cap is installed to denote the appropriate knee location.

ITEM	Description	Qty
40	Aluminum Cap 50x10.5x8	2
50	Flat Washer 13x24x2.5	8
52	M12 Nylon Lock Nut	4
54	M10x25 Flat Head Cap Screw	2
65	M12x35 Socket Head Cap Screw	4

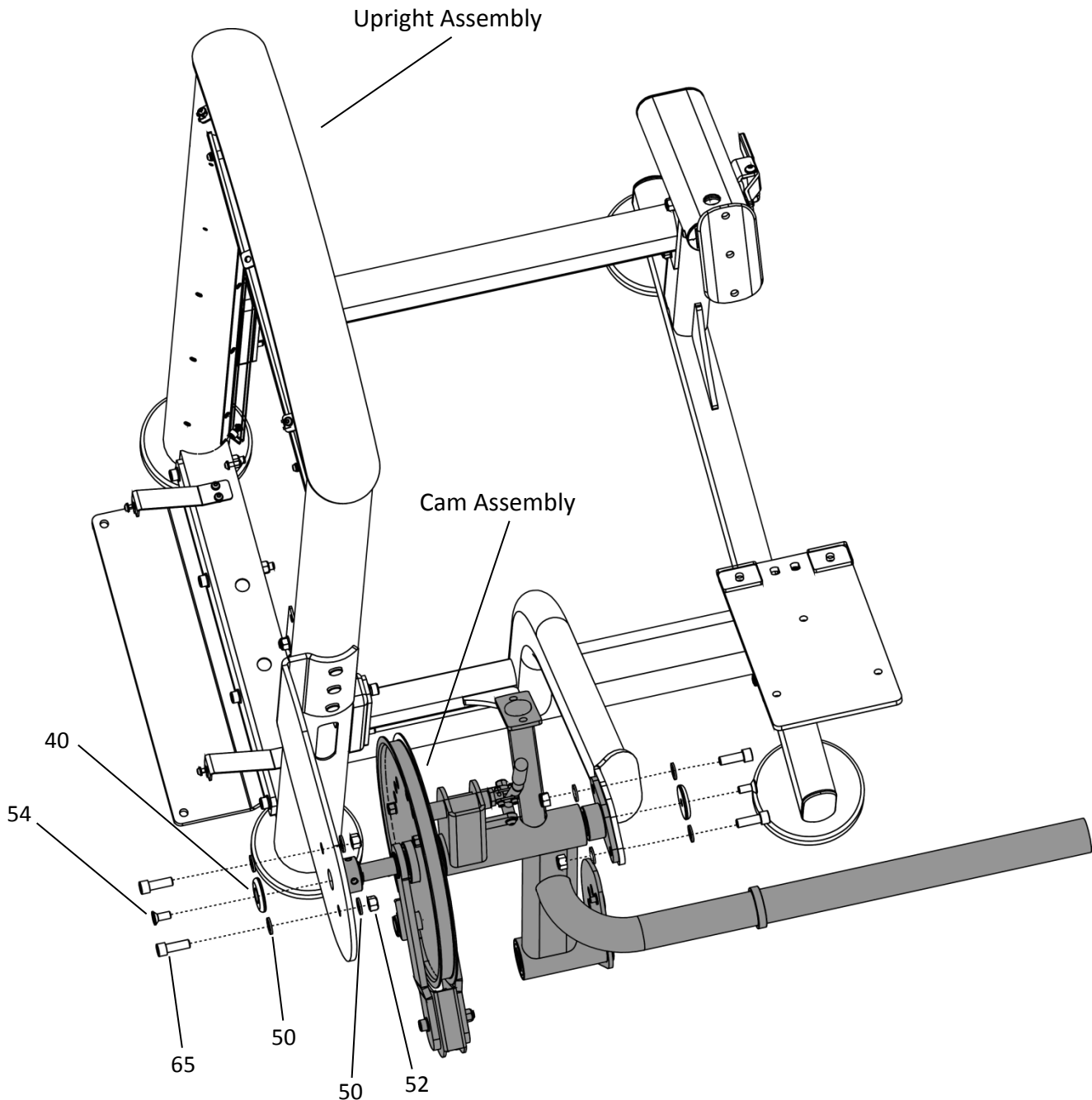

CHAPTER 2: ASSEMBLY GUIDE

UNIT ASSEMBLY STEPS (CONTINUED):

STEP 9 Ankle Support Arm:

1. Attach the Ankle Support Arm to the Cam Assembly as shown.

ITEM	Description	Qty
41	Aluminum Cap 50x10.5x8	1
54	M10x25 Flat Head Cap Screw	1

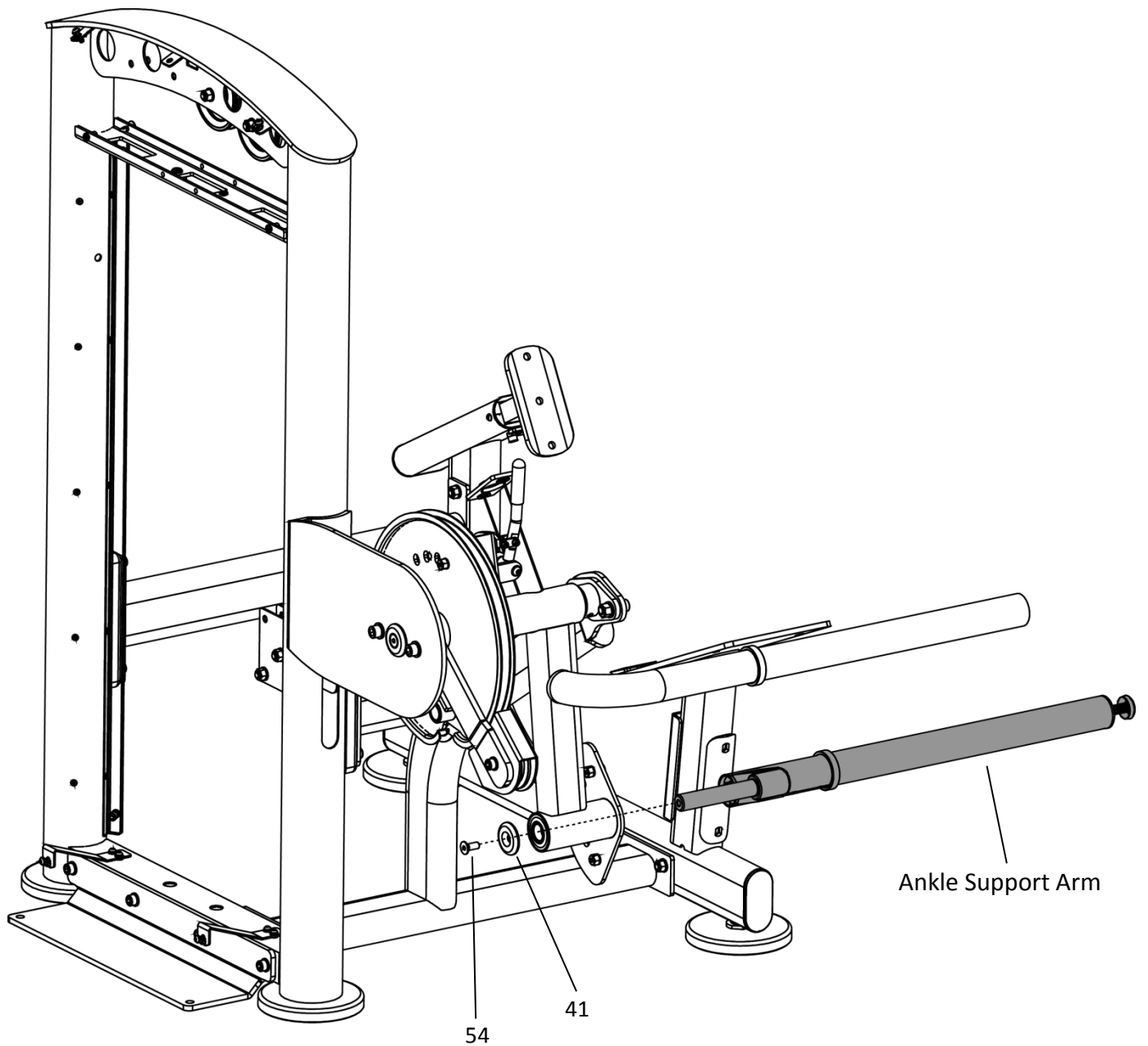

CHAPTER 2: ASSEMBLY GUIDE

UNIT ASSEMBLY STEPS (CONTINUED):

STEP 10 Counter-Weight:

1. Attach the Counter-Weight to the Cam Assembly as shown.

ITEM	Description	Qty
49	Flat Washer 11x20x2	2
60	M10x25 Socket Head Cap Screw	2

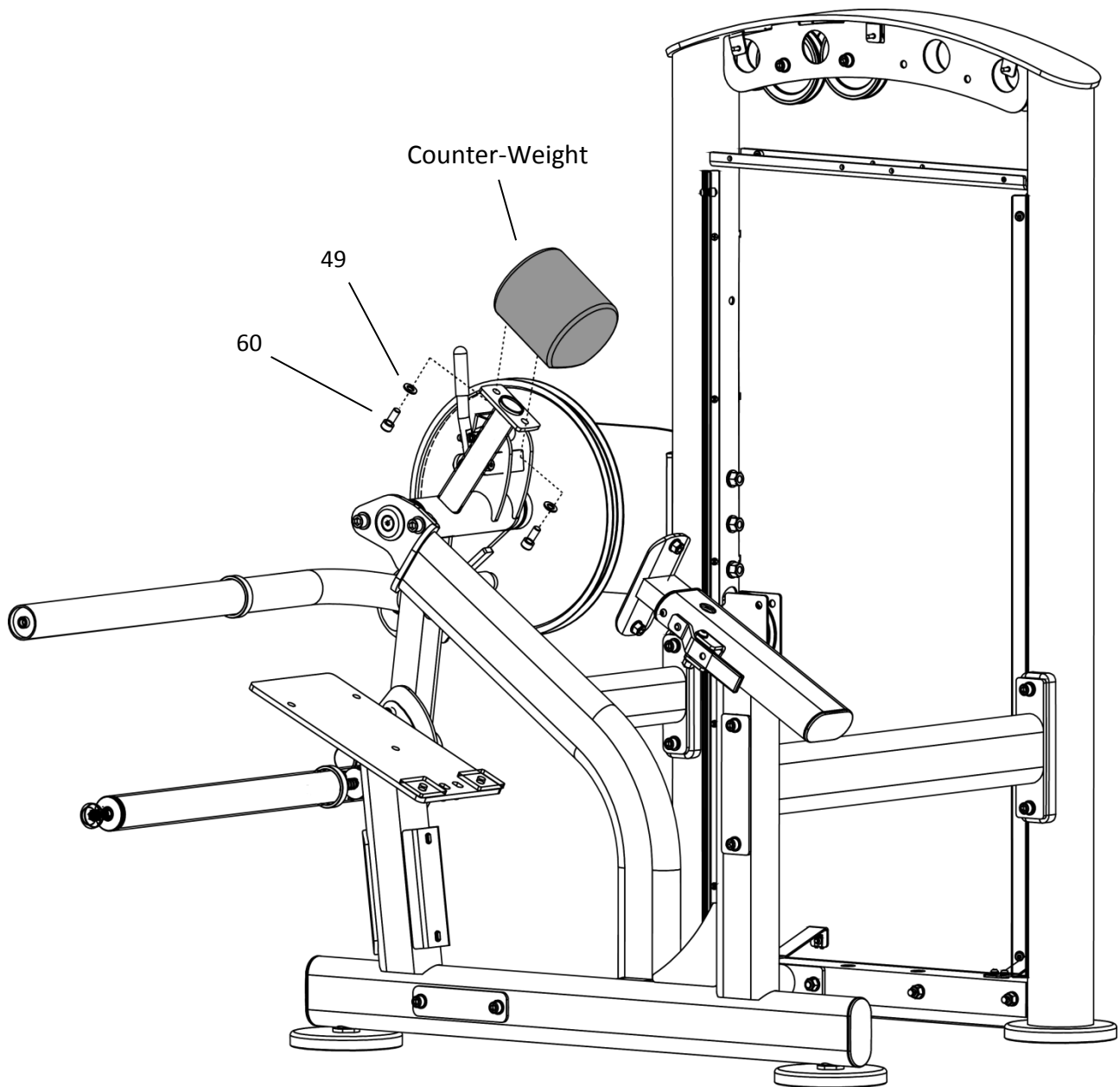

CHAPTER 2: ASSEMBLY GUIDE

UNIT ASSEMBLY STEPS (CONTINUED):

STEP 11 Handle Bar:

1. Attach the Handle Bar to the Seat Frame as shown.

ITEM	Description	Qty
49	Flat Washer 11x20x2	6
51	M10 Nylon Lock Nut	4
55	M10x30 Flat Head Cap Screw	2
64	M10x135 Socket Head cap Screw	2

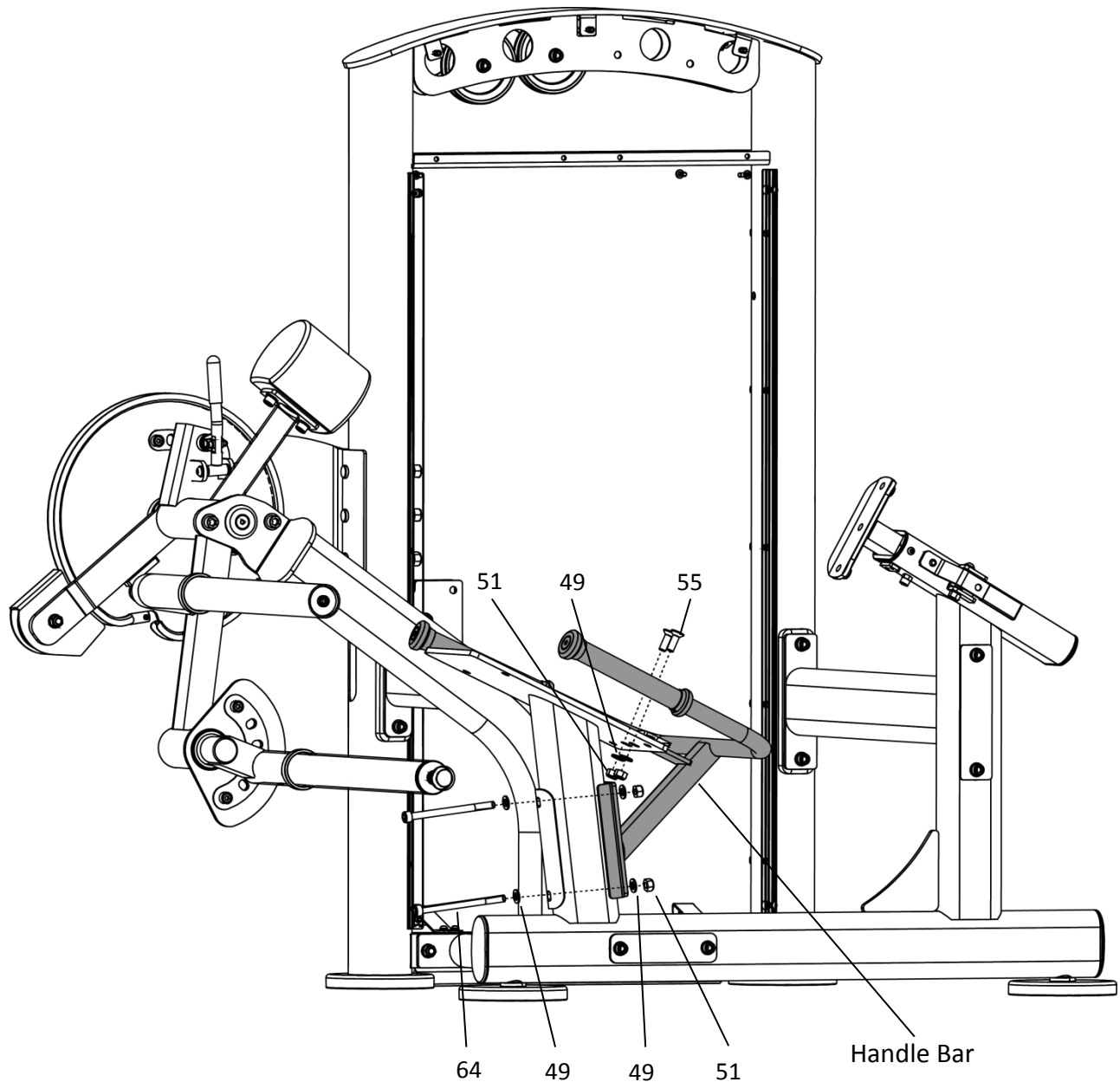

CHAPTER 2: ASSEMBLY GUIDE

UNIT ASSEMBLY STEPS (CONTINUED):

STEP 12 Seat Pad Frame:

1. Attach the Back Pad Frame to the Seat Frame as shown.

ITEM	Description	Qty
49	Flat Washer 11x20x2	4
51	M10 Nylon Lock Nut	2
57	M10x30 Button Head Cap Screw	2

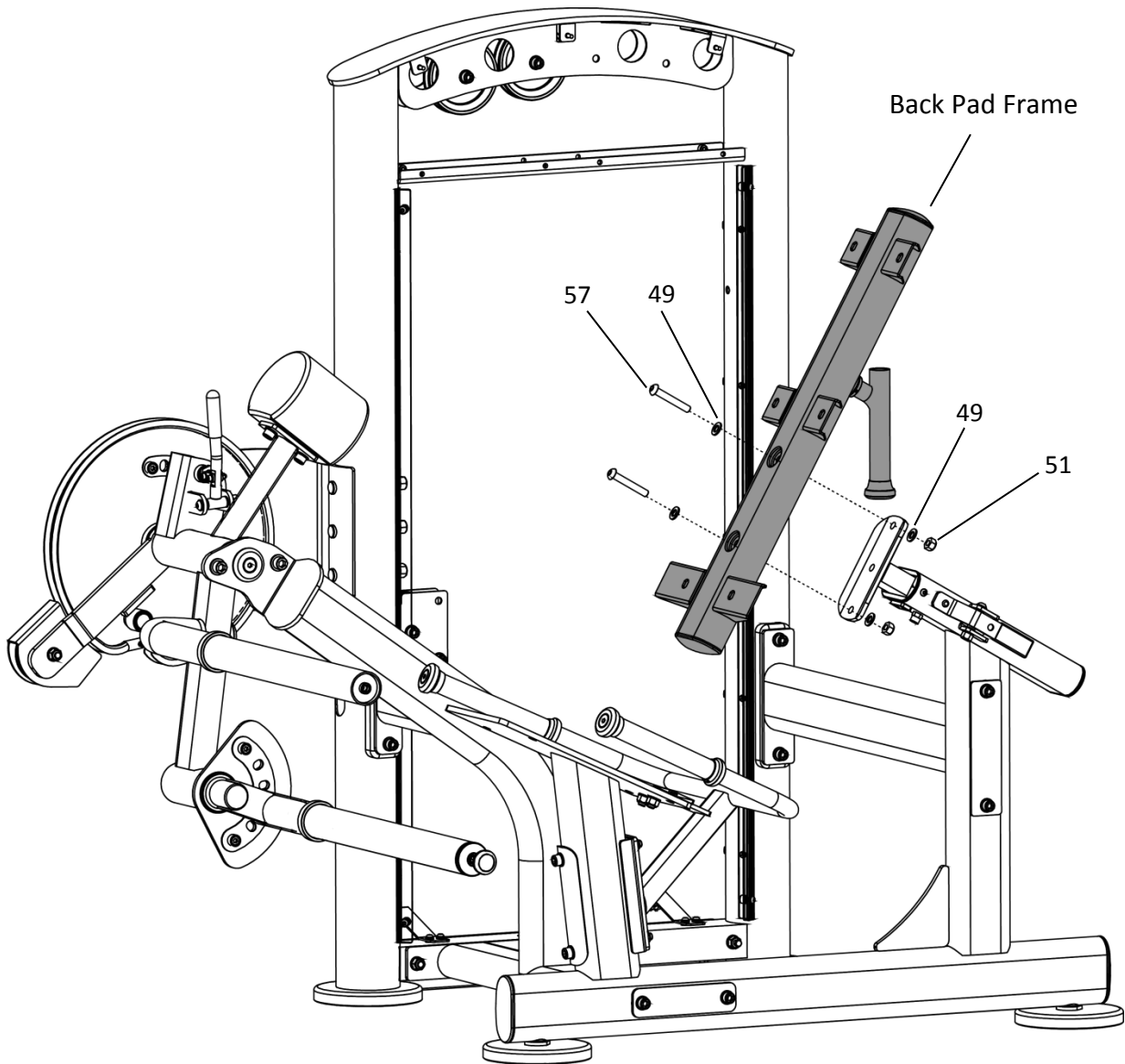

CHAPTER 2: ASSEMBLY GUIDE

UNIT ASSEMBLY STEPS (CONTINUED):

STEP 13 Seat Pad Support:

1. Attach the Seat Pad Support to the Seat Frame as shown.

ITEM	Description	Qty
49	Flat Washer 11x20x2	2
51	M10 Nylon Lock Nut	2
55	M10x30 Flat Head Cap Screw	2

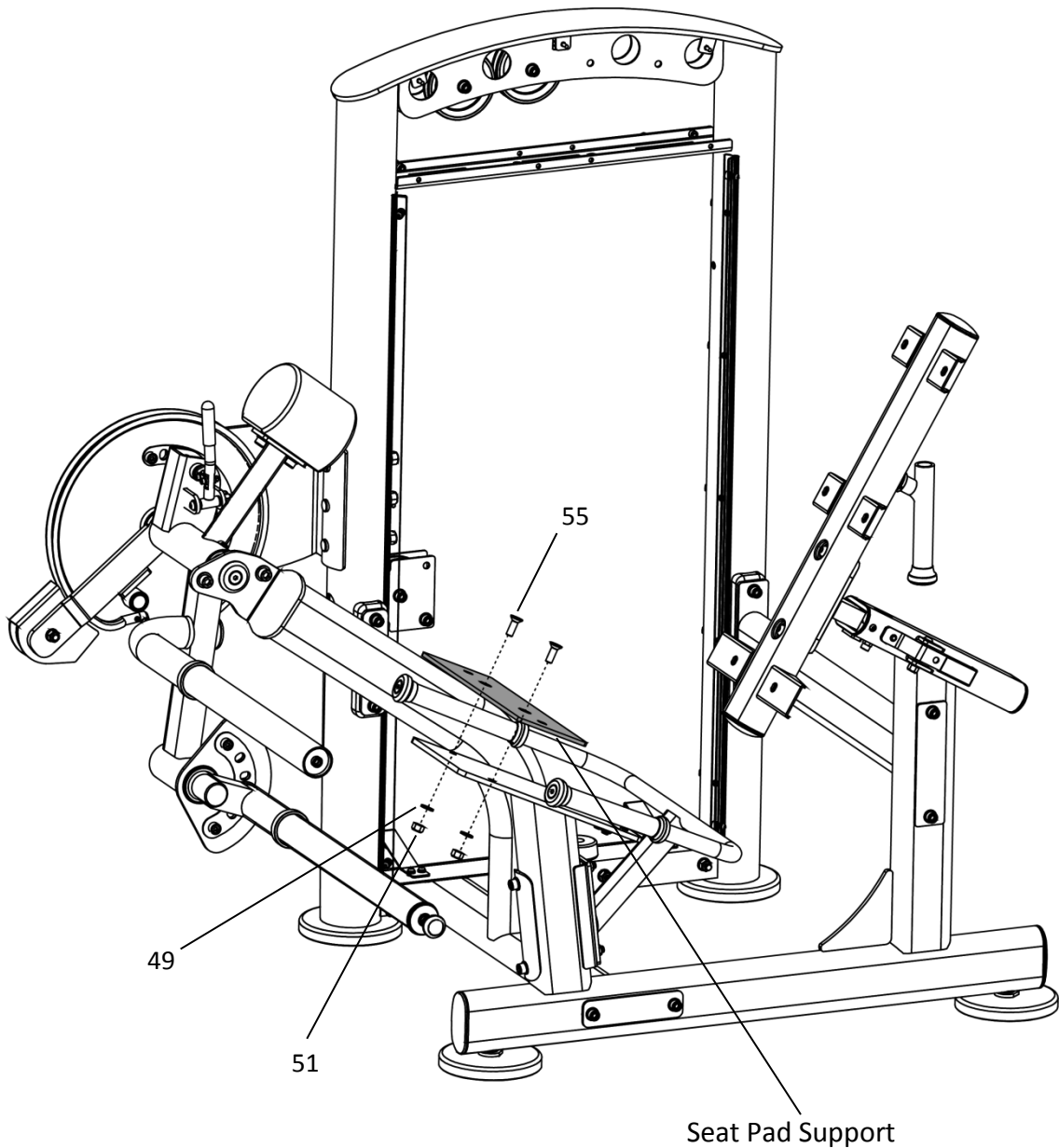

CHAPTER 2: ASSEMBLY GUIDE

UNIT ASSEMBLY STEPS (CONTINUED):

STEP 14 Weight Stack Assembly:

1. Assemble and install the guide rods and weight stack to the upright assembly as shown below.

ITEM	Description	Qty
36	Rubber Weight Bumper	2
37	Rubber Plug	2
45	#8 Lock Washer	2
48	Flat Washer 9x16x1.6	2
58	M8x30 Socket Head Cap Screw	2

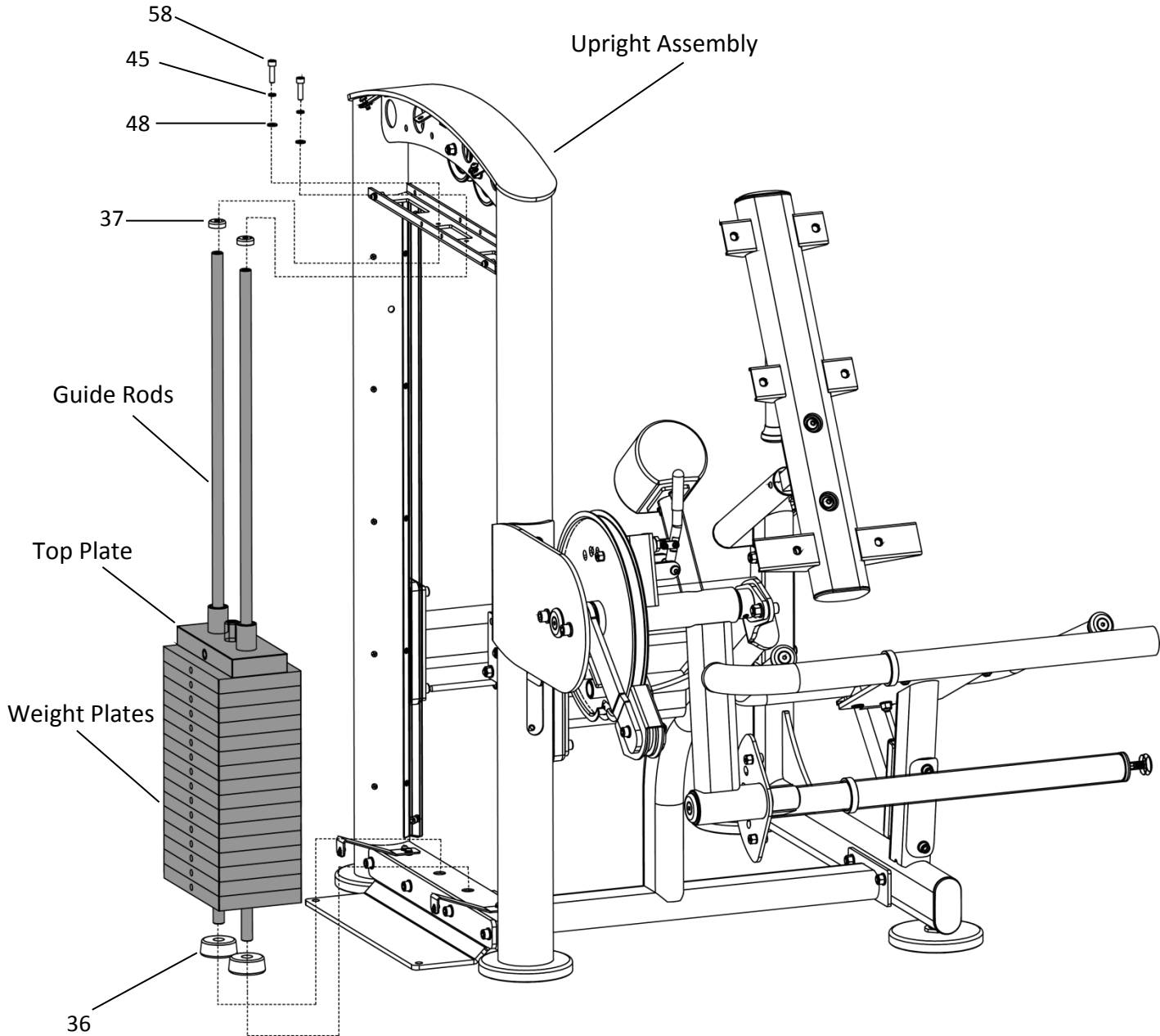

CHAPTER 2: ASSEMBLY GUIDE

UNIT ASSEMBLY STEPS (CONTINUED):

STEP 15 Cable Routing:

1. Route the cable as shown.
2. Verify that there is no more than one inch (25mm) of the cable thread is left exposed.
3. Tighten the cable nut on the cable bolt against the top plate.

ITEM	Description	Qty
15	Cable Assy	1

⚠ CAUTION:

A minimum of 1/2 inch (12.7mm) of the threaded portion of the cable bolt must be threaded into the top plate.

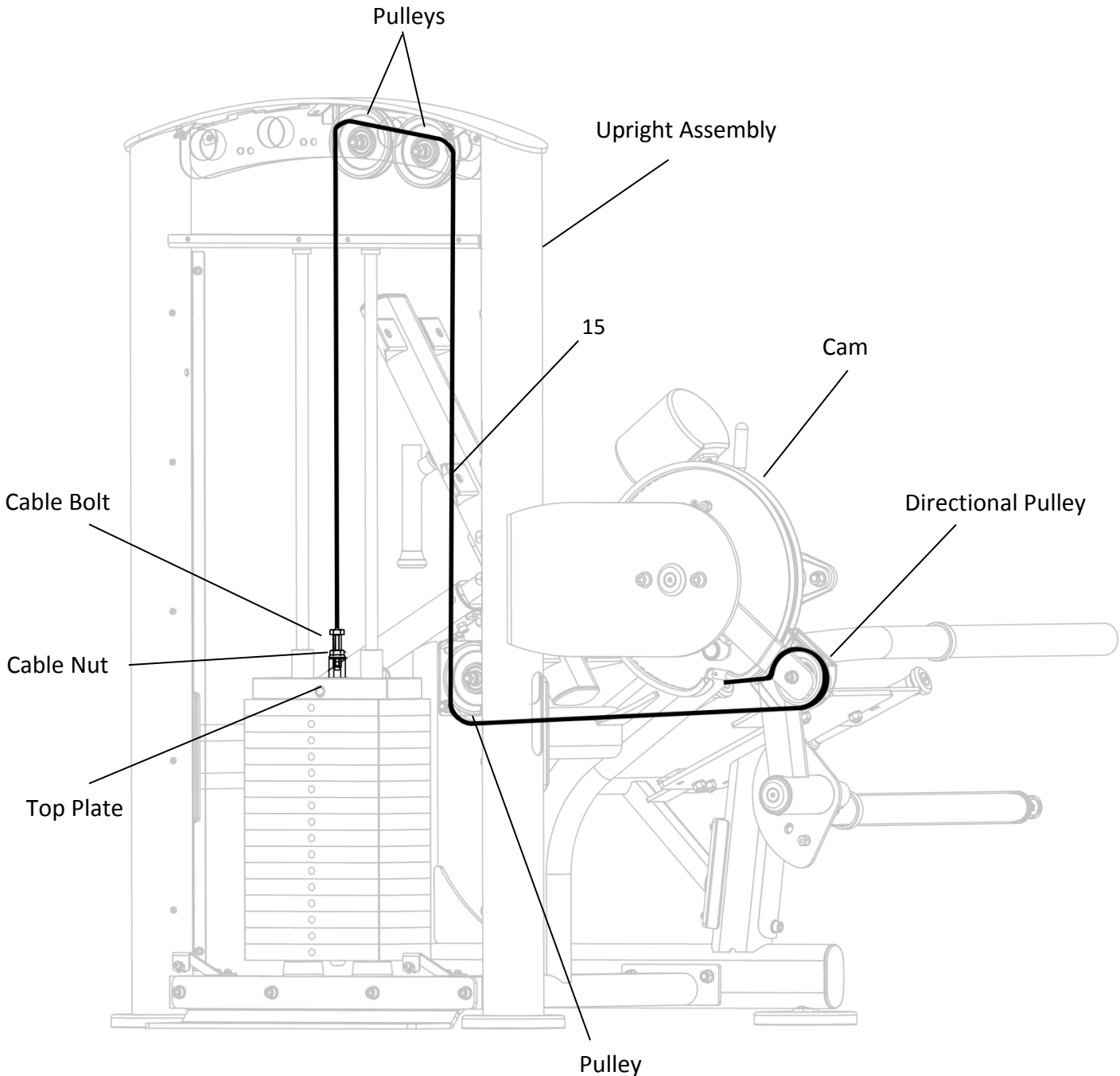

CHAPTER 2: ASSEMBLY GUIDE

UNIT ASSEMBLY STEPS (CONTINUED):

STEP 16 Outer Top Shroud Support:

1. Attach the Outer Top Shroud Support to the Upright Assembly as shown.

ITEM	Description	Qty
44	#6 Lock Washer	2
47	Flat Washer 6.6x12x1.6	2
56	M6x20 Button Head Cap Screw	2

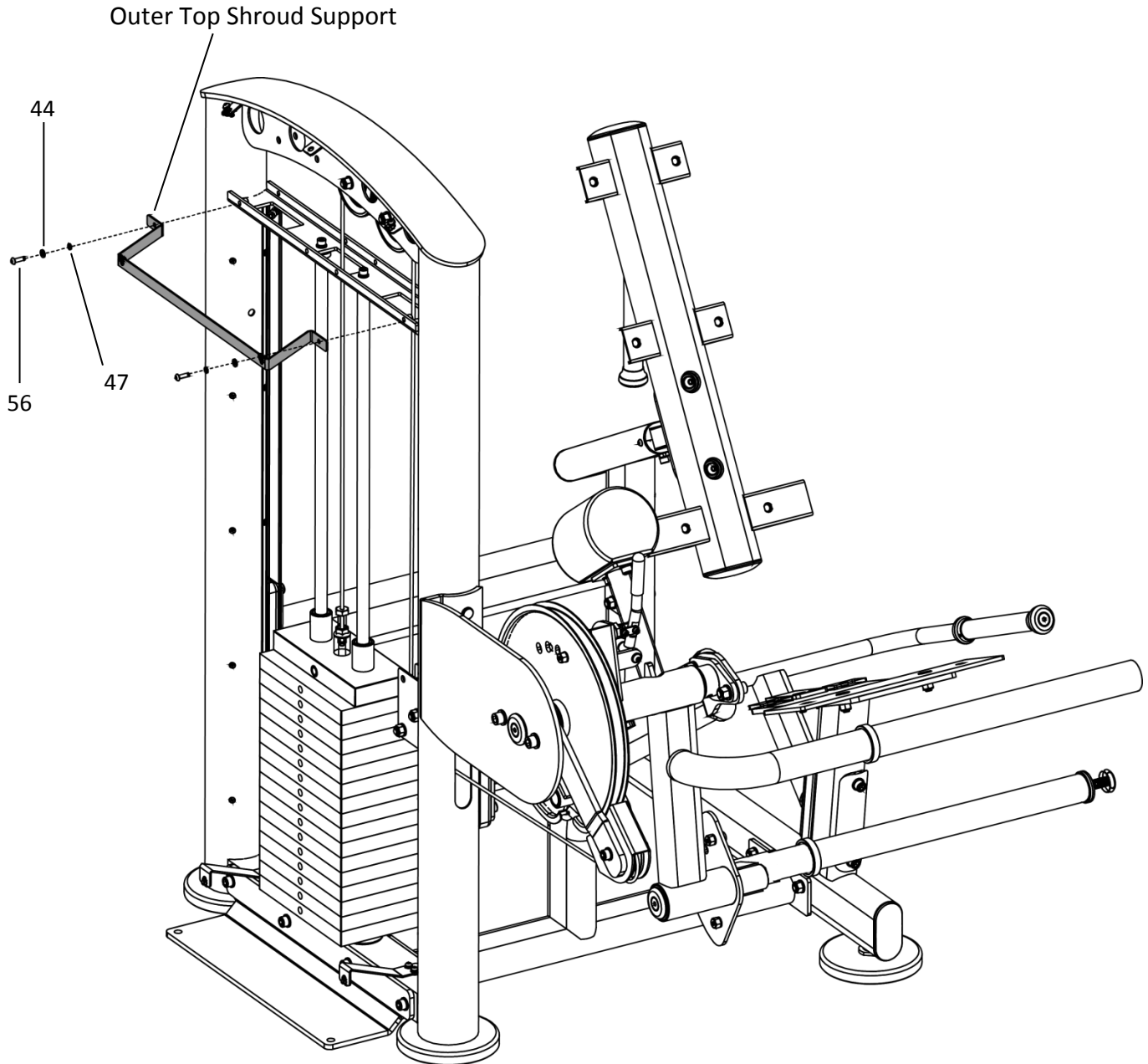

CHAPTER 2: ASSEMBLY GUIDE

UNIT ASSEMBLY STEPS (CONTINUED):

STEP 17 Outer Shroud Supports:

1. Attach the Outer Shroud Supports to the Upright Assembly as shown below.

ITEM	Description	Qty
53	M5x16 Countersunk Pan Head Screw	10

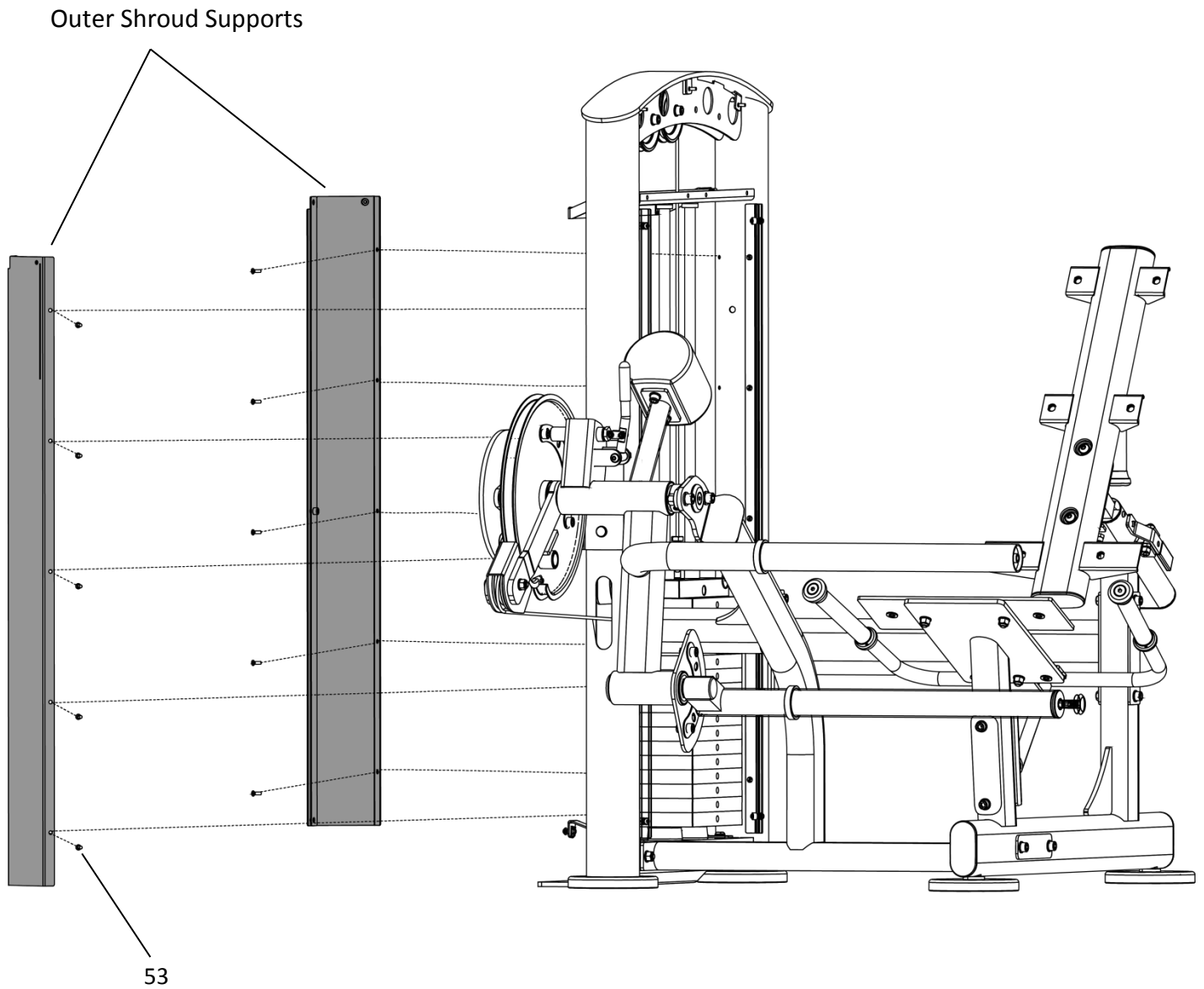

CHAPTER 2: ASSEMBLY GUIDE

UNIT ASSEMBLY STEPS (CONTINUED):

STEP 18 Seat Pad:

1. Attach the Seat Pad to the Seat Frame as shown.

ITEM	Description	Qty
49	Flat Washer 11x20x2	4
61	M10x30 Socket Head Cap Screw	4

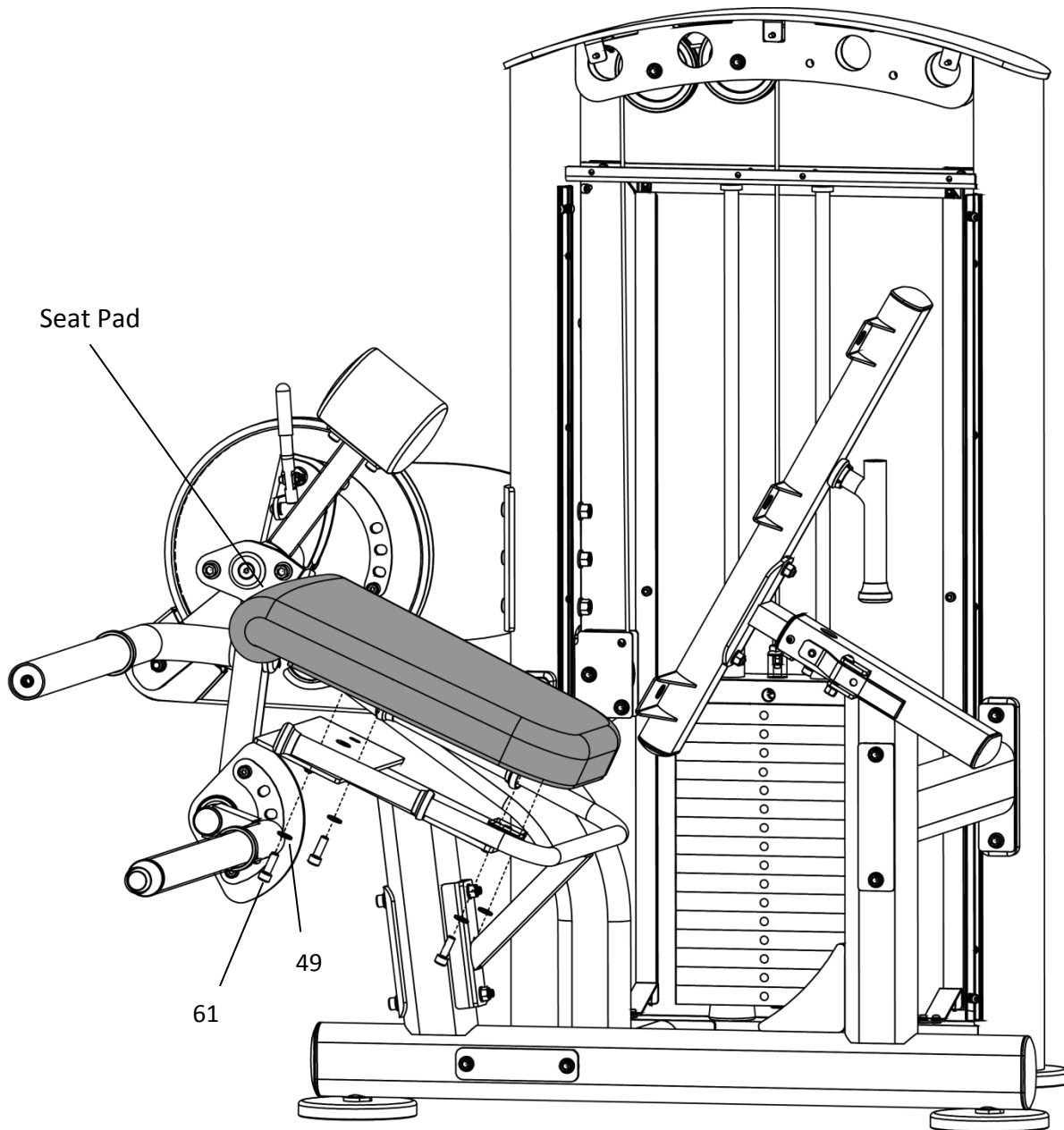

CHAPTER 2: ASSEMBLY GUIDE

UNIT ASSEMBLY STEPS (CONTINUED):

STEP 19 Roller Pads:

1. Install the Roller Pads as shown.

ITEM	Description	Qty
35	Aluminum End Cap 60x10.5x10.9	1
38	Large Collar 90x51.2x8.5	4
39	Small Collar	1
43	Socket Head Set Screw 10-32x6.4	2
54	M10x25 Flat Head Cap Screw	1

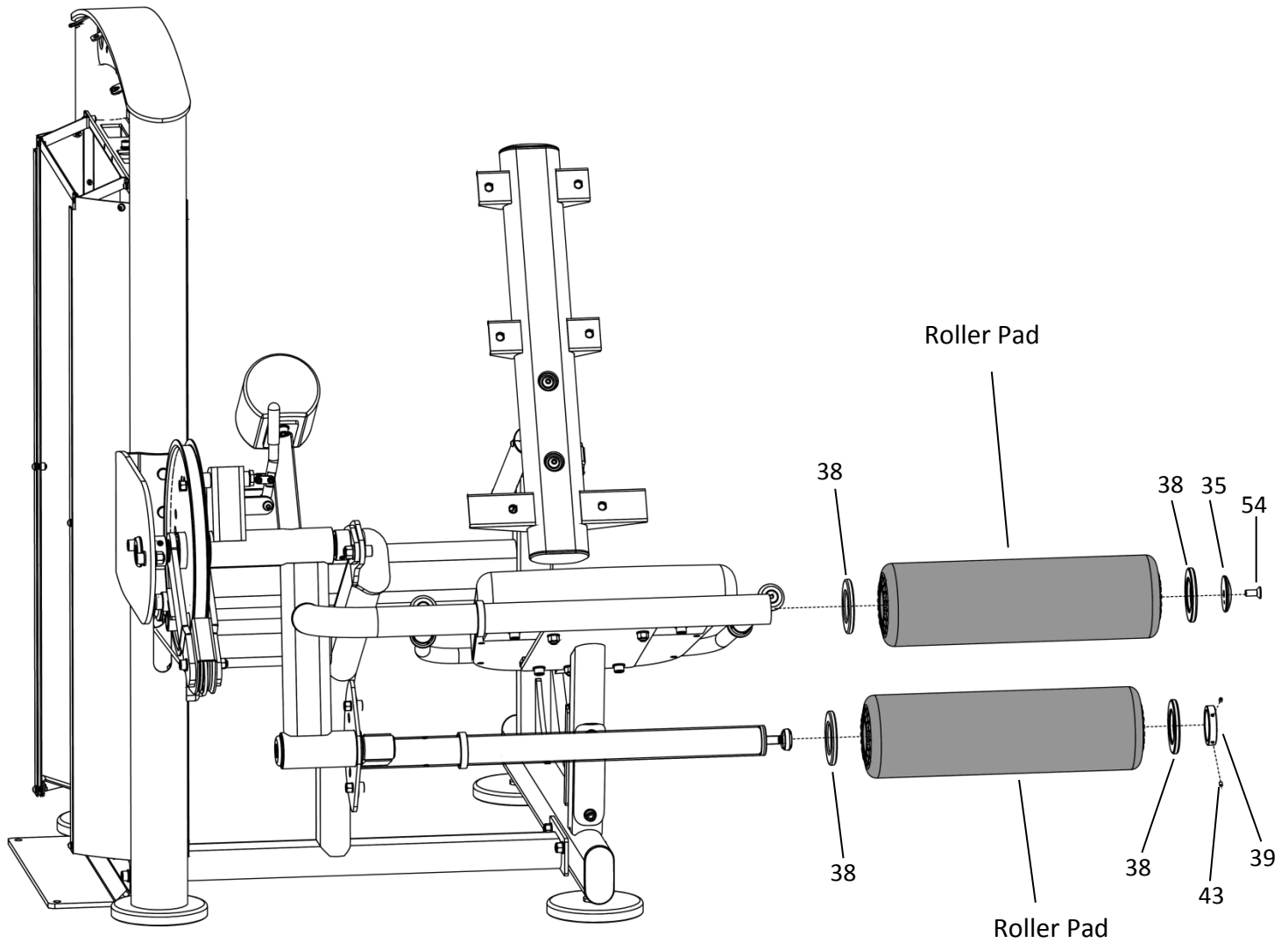

CHAPTER 2: ASSEMBLY GUIDE

UNIT ASSEMBLY STEPS (CONTINUED):

STEP 20 Head and Back Pads:

1. Install the Head and Back Pads as shown.

ITEM	Description	Qty
49	Flat Washer 11x20x2	6
61	M10x30 Socket Head Cap Screw	6

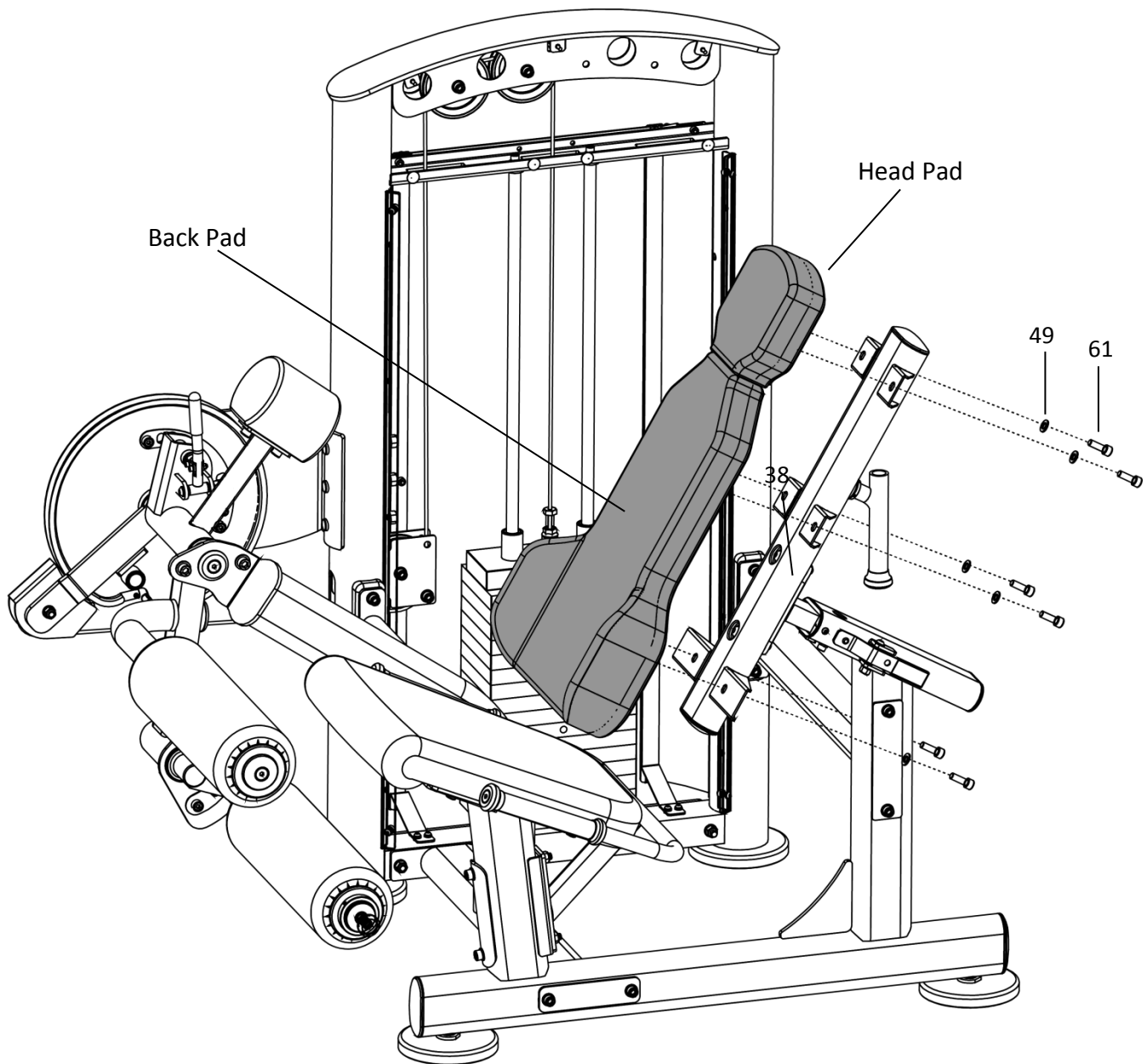

CHAPTER 2: ASSEMBLY GUIDE

UNIT ASSEMBLY STEPS (CONTINUED):

STEP 21 Placard Frame:

1. Attach the Placard Frame to the Upright Assembly as shown below.

ITEM	Description	Qty
34	Button Clip	4
53	M5x16 Countersunk Pan Head Screw	3

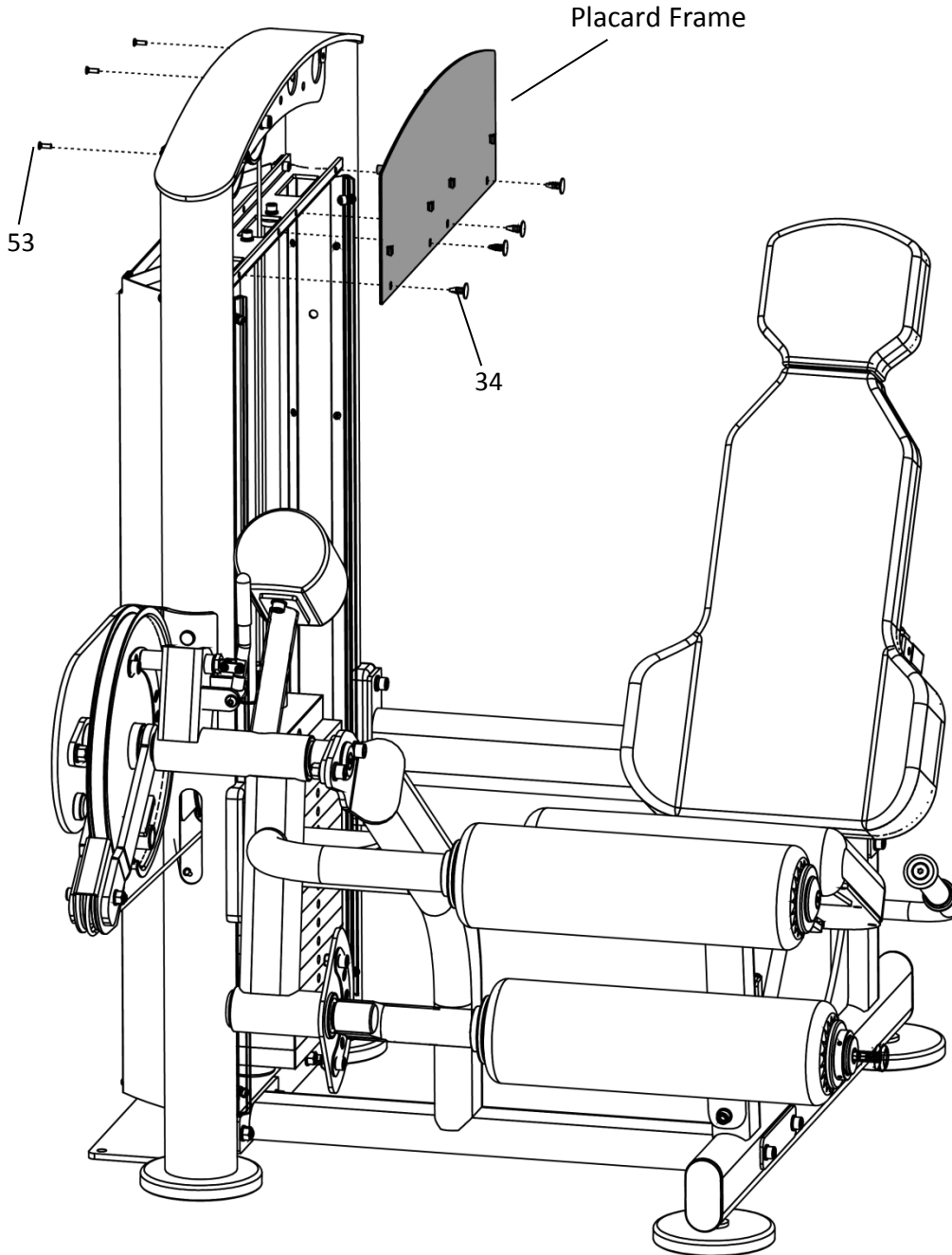

CHAPTER 2: ASSEMBLY GUIDE

UNIT ASSEMBLY STEPS (CONTINUED):

STEP 22 Inner Shroud:

1. Slide the Inner Shroud down into the Inner Shroud Supports.

ITEM	Description	Qty
47	Flat Washer 6.6x12x1.6	4
56	M6x20 Button Head Cap Screw	4

2. Secure the shroud with four screws and four washers as shown below.

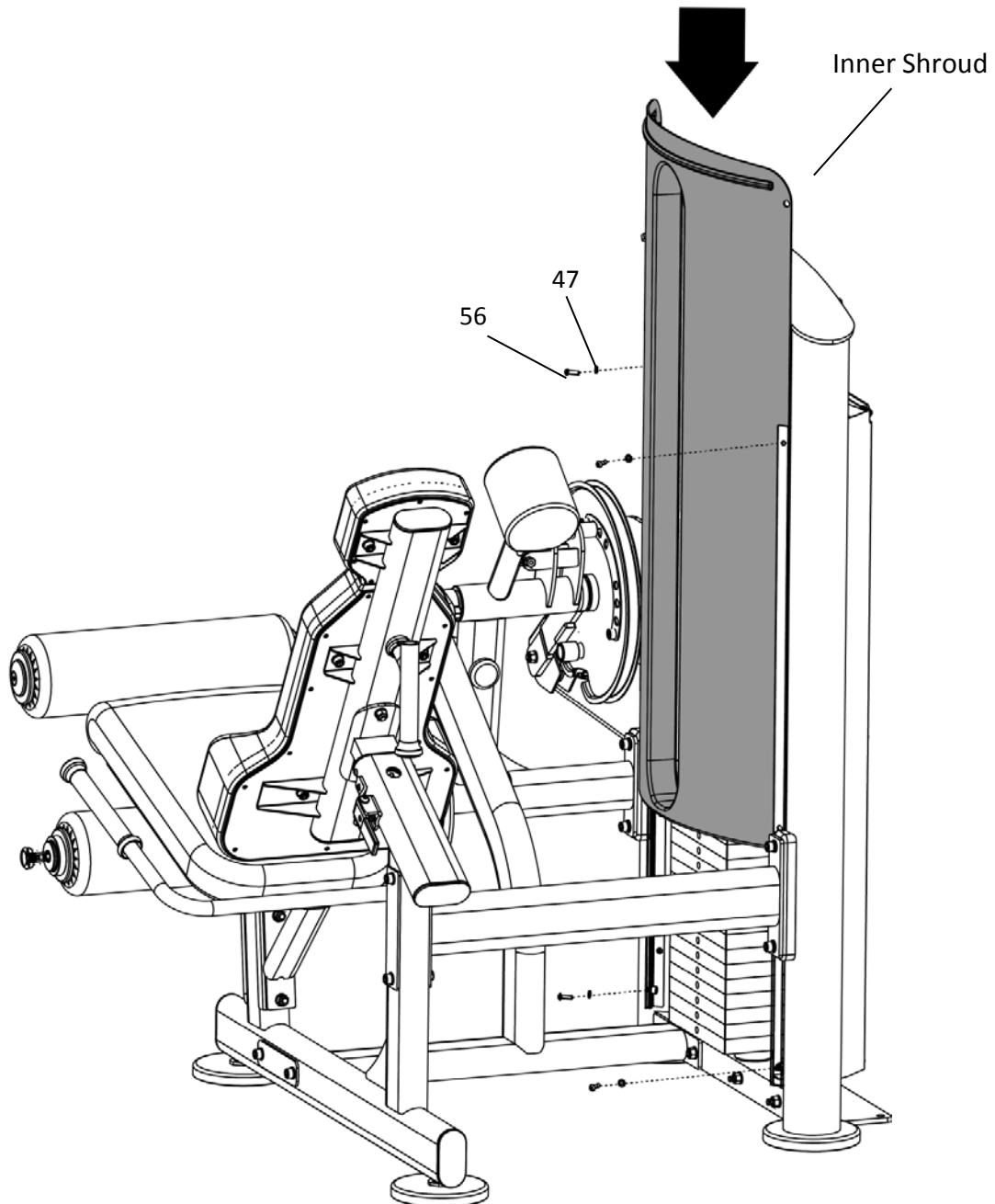

CHAPTER 2: ASSEMBLY GUIDE

UNIT ASSEMBLY STEPS (CONTINUED):

STEP 23 Accessory Tray:

1. Secure the Accessory Tray to the Placard Frame by snapping it into place followed by sliding it down onto the front shroud.

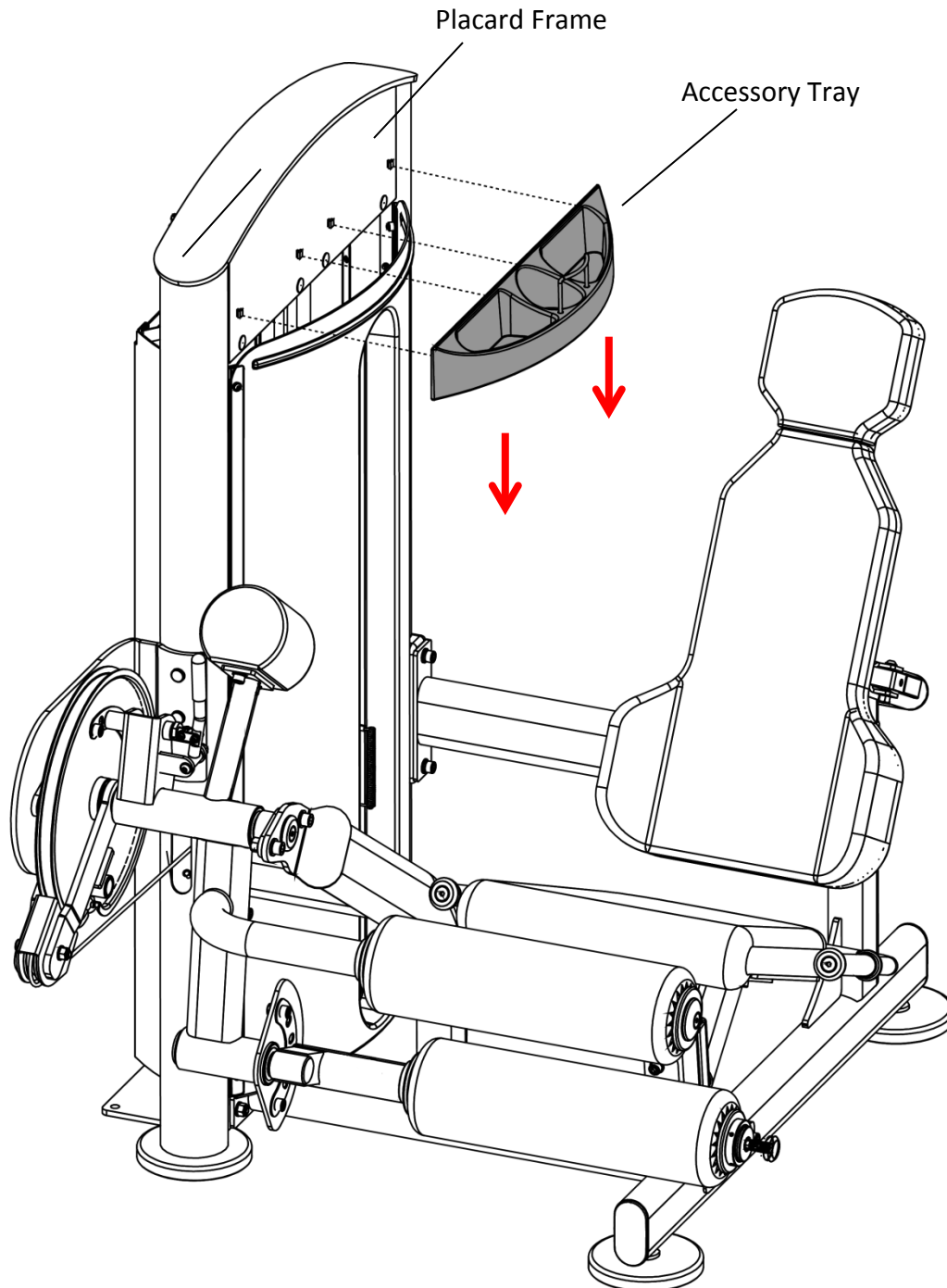

CHAPTER 2: ASSEMBLY GUIDE

UNIT ASSEMBLY STEPS (CONTINUED):

STEP 24 Outer Shroud:

1. Slide the Outer Shroud down into the Outer Shroud Supports.

ITEM	Description	Qty
47	Flat Washer 6.6x12x1.6	4
56	M6x20 Button Head Cap Screw	4

2. Secure the shroud with four screws and four washers as shown below.

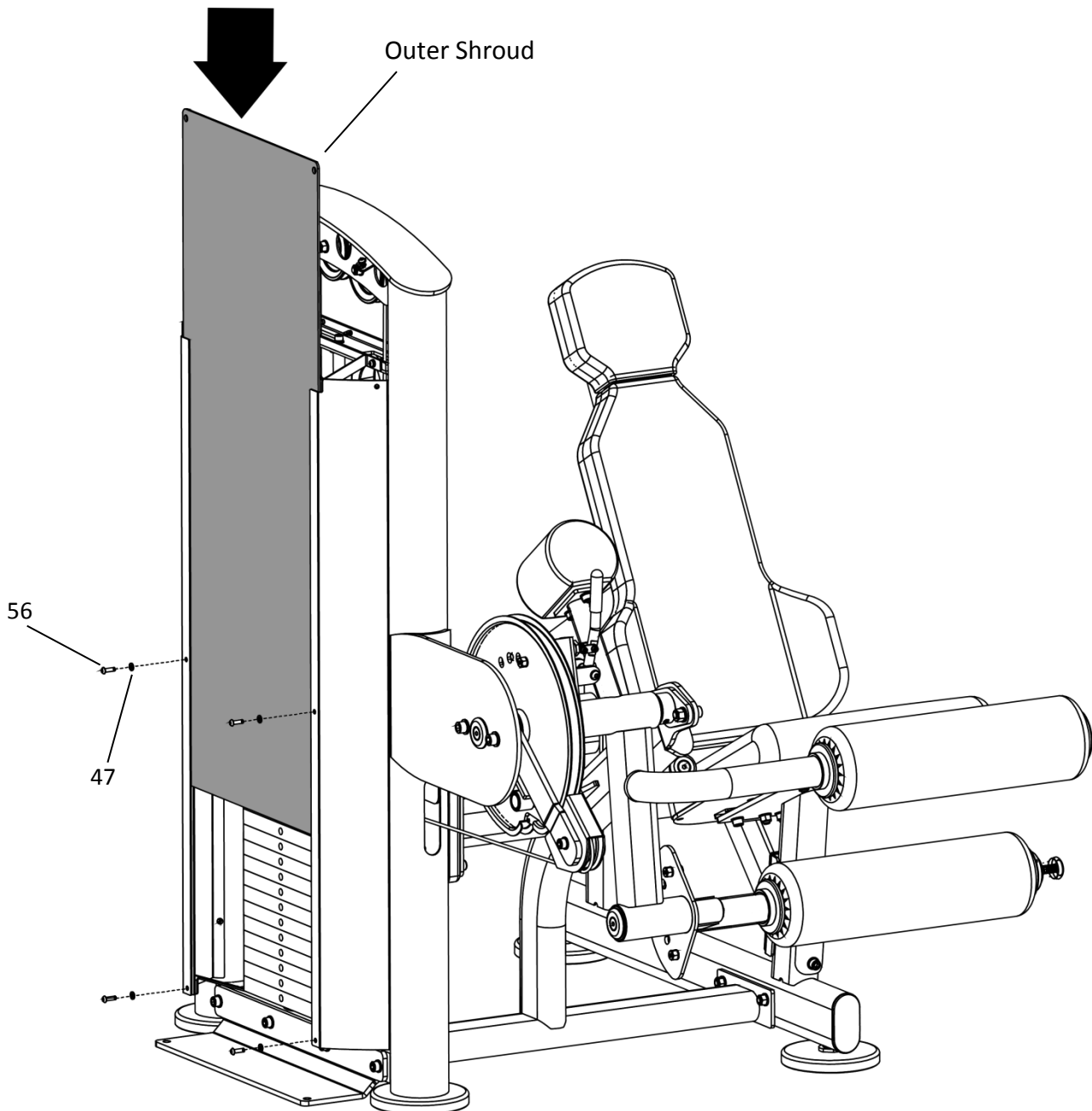

CHAPTER 2: ASSEMBLY GUIDE

UNIT ASSEMBLY STEPS (CONTINUED):

STEP 25 Outer Shroud Cap:

1. Install the Outer Shroud Cap as shown.

ITEM	Description	Qty
47	Flat Washer 6.6x12x1.6	6
56	M6x20 Button Head Cap Screw	6

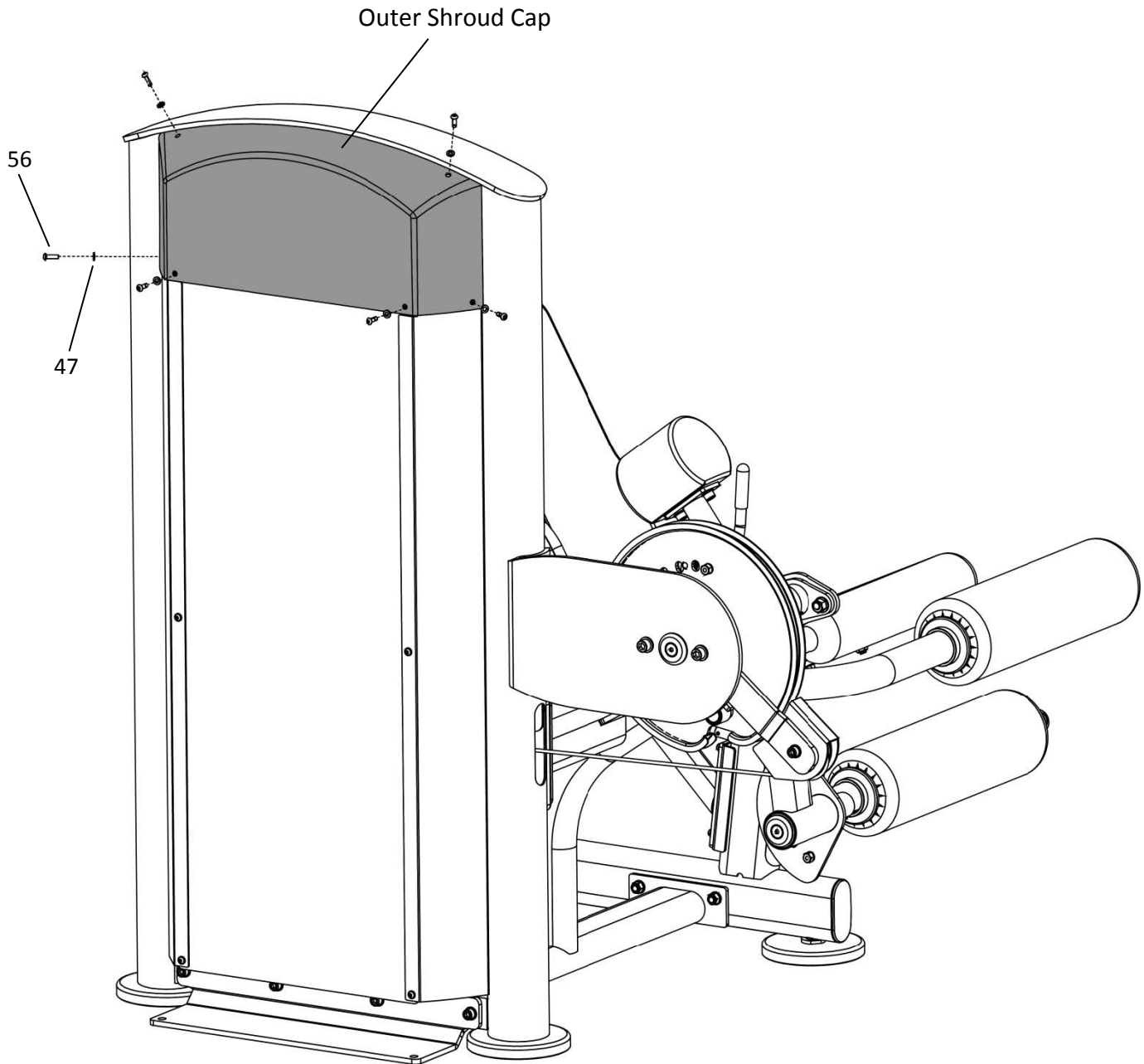

CHAPTER 2: ASSEMBLY GUIDE

UNIT ASSEMBLY STEPS (CONTINUED):

STEP 26 Selector Pin:

1. Install the Selector Pin as shown.
2. Attach the Selector Pin restraint ring to the weight cable.

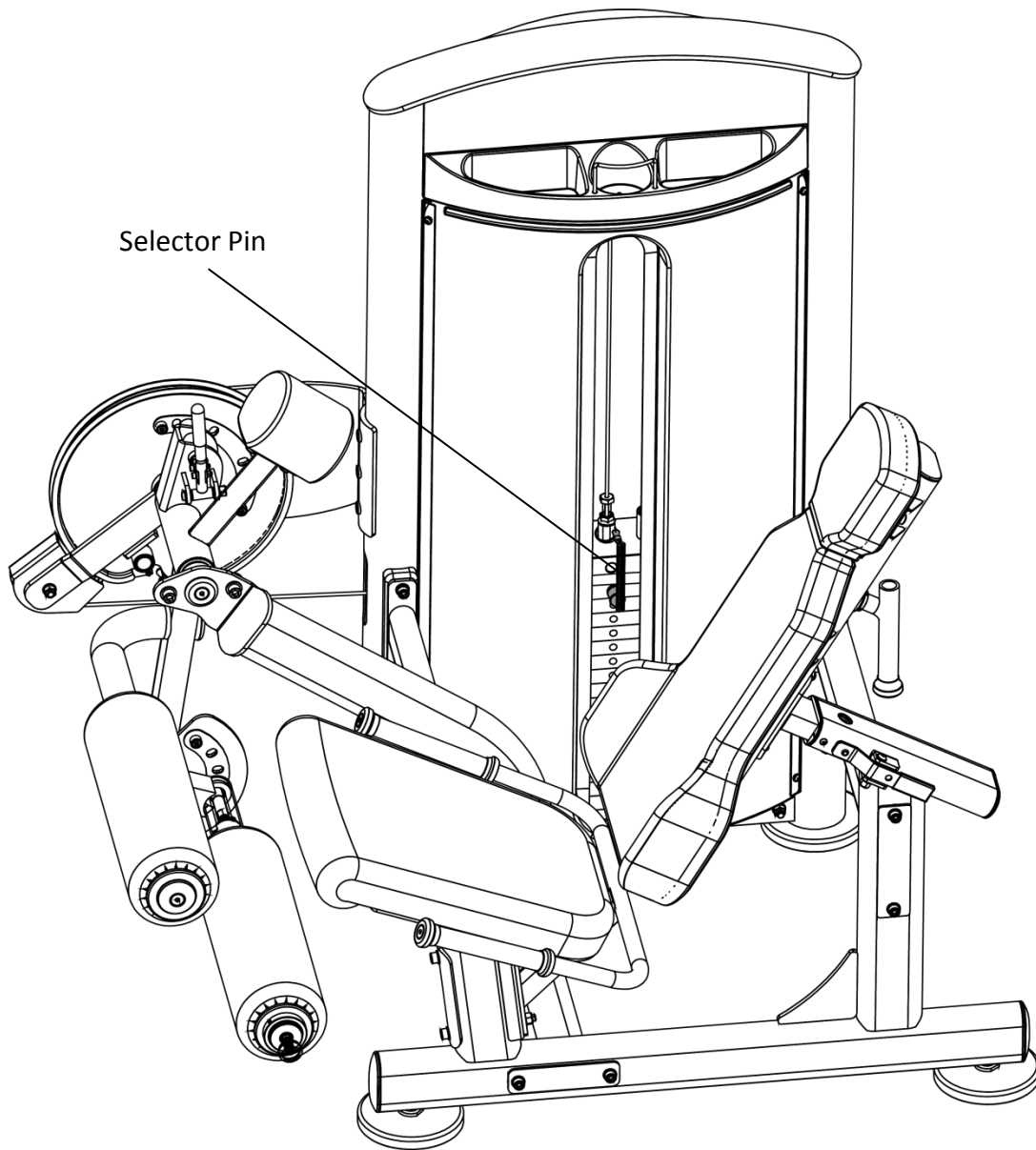

CHAPTER 3: PRODUCT OVERVIEW

PRODUCT OVERVIEW:

Movement Arm Adjustment Lever

Weight Stack Adjustment Pin



Ankle Pad Adjustment Pin

Back Pad Adjustment Lever

CHAPTER 4: CARE & MAINTENANCE

CARE & MAINTENANCE:

Preventative maintenance is crucial to maintaining the function and safety of this equipment. Your facility must establish written guidelines for preventative maintenance and keep written or online records of the maintenance performed on these products. As a minimum, the items presented in the Safety Instructions section of this document and the items that follow here, should be included in your maintenance program.

IMPORTANT: Always purchase replacement parts from TRUE Fitness. Parts are tested and manufactured specifically for TRUE Fitness equipment. Use of unapproved parts may cause serious injury and/or void the limited warranty.

DAILY INSPECTION & MAINTENANCE:

The following items are critical to the safety of users and maintenance staff as well as to ensure the optimum performance of the machines. These inspections should be performed each day before the equipment is subject to use. TRUE Fitness is not responsible for performing or scheduling regular maintenance or inspections.

- Inspect cables for wear, tension and proper connection (as described in the cable inspection section below).
- Inspect all adjustment pins, weight stack pins, set screws, gas shocks, snap links, and pulleys.
- Inspect all safety and instructional decals.
- Inspect all weight stack shields.
- Verify that rubber hand grips are intact and secure.
- Verify that anti-skid foot grips are intact and secure
- Verify that the weight stack selector pin is attached with the coiled lanyard to the top plate.

WEEKLY INSPECTION & MAINTENANCE:

The following items are critical to the safety of users and maintenance staff as well as ensuring the optimum performance of the machines. These inspections should be performed each week. TRUE Fitness is not responsible for performing or scheduling regular maintenance or inspections.

- Check entire length of cable & end fittings for any signs of wear. Replace immediately as required. (Refer to Daily Maintenance Section).
- Verify that A minimum of 1/2 inch (12.7mm) of the threaded portion of the cable bolt is threaded into the top plate and that the nut is tight. (See Cable Inspection & Maintenance Section).
- Perform a function test by placing the selector pin in the TOP PLATE and Cycling the machine through the intended motion. Verify that the machine operates smoothly without binding. Select a moderate weight and repeat.
- Verify that each pulley rotates freely when performing the exercise. A pulley that does not rotate will cause extreme cable wear and could lead to cable failure. Determine cause of the pulley issue and remedy immediately.
- Verify that the adjustment pop pins retract easily and fully engage (when released) into each adjustment disc hole/slot. The pop pins are spring loaded so they should return to the engaged position when you release the knob.
- Verify that all hardware (nuts/bolts and fasteners) is tight and that associated frame members are secure. Apply a few small drops of a thread locking compound such as Loctite on any loose bolts.
- Inspect frame for integrity and function. Replace any components at the first sign of wear with only TRUE supplied parts.

CHAPTER 4: CARE & MAINTENANCE

OTHER SCHEDULED PREVENTIVE MAINTENANCE:

TRUE recommends that scheduled maintenance be performed by a qualified service technician. Please contact your dealer or visit www.truefitness.com to contact a local TRUE authorized service technician.

Monthly:

Clean guide rods and lubricate with a Teflon lubricant.

Every 6 months:

Lubricate pivot bearings with lithium grease.

CLEANING THE EQUIPMENT:

Daily Cleaning:

Wipe all machines with a water dampened cloth and dry completely. This includes painted parts, chrome plated parts (except guide rods), plastic parts, and upholstered pads. It is important not to leave parts damp. This will increase the potential for corrosion to occur.

CAUTION:

Certain anti-bacterial cleaners and other harsh cleaning agents can induce corrosion on the machine components. These solutions can also dry out and cause cracking and splitting of the upholstery.

Heavy Duty Cleaning:

Guide Rods: Clean and lubricate with a Teflon Spray. Be sure to coat the entire guide rod. Spraying lubricant into the cap plate bushings is also recommended.

Chromed Adjustment Tubes: Wipe away dust and dirt before applying a Teflon spray lubricant. TRUE Fitness recommends using TriFlow or a similar brand.

Painted Frames: If you have scuff marks, grease or a heavy dirt buildup on frame components, start with a mild soap solution or a diluted solution of a product such as Simple Green. If you cannot remove the marks using those methods, use a car polish/cleaner. DO NOT use solvents such as lacquer thinner, mineral spirits or acetone. For deeper scuff marks, use an automobile finish rubbing compound.

Upholstery: For heavy duty cleaning, use a mild soap solution. This method should be sufficient in the majority of instances. In severe stain cases, you can use a solution of 5-10% household bleach diluted with water. Be sure to test an inconspicuous area first. DO NOT use chemical cleaners on the vinyl upholstery. You can also use a lanolin based hand cleaner to clean your upholstery. Wipe off after cleaning with a damp cloth and thoroughly dry.

Plastic Parts: Use a mild soap solution to clean dirt and grease marks.

Labels: Use a mild soap solution to clean dirt and grease marks.

Shrouds: Use a mild soap solution to clean dirt and grease marks.

CAUTION:

Do not use any acidic cleaners. Doing so will weaken the paint or powder coatings and may void the TRUE Fitness Warranty. Never pour or spray liquids on any part of the equipment. Allow the equipment to dry completely before using.

CHAPTER 4: CARE & MAINTENANCE

▲ CAUTION:

If you determine that the equipment needs service, make sure that the equipment cannot be used inadvertently and ensure other users know that the machine needs service.

*To order parts or to contact a TRUE Authorized Service representative, please visit www.truefitness.com

CABLE INSPECTION & MAINTENANCE:







One of the most critical areas that require frequent inspection on any weight machine is the cable or belt system that lifts the weight stack. Sudden failure of a worn cable can in some instances, result in injury to the user. It is the responsibility of the facility to inspect the cables frequently.

Cables are components that wear over time. This means that the more often a piece of equipment is used, the greater the likelihood that cable wear will occur. This holds true for equipment made by any manufacturer and applies to urethane belts as well as wire rope cables. Listed below are the areas of the cable that require inspection.

*TRUE Fitness recommends that all cables be replaced on an annual basis to maintain the safety of all users.

Cable Wear:

Inspect all cables for any signs of wear. Pay close attention to the cable in the area of the end fittings and attachment points. Inspect the areas around the pulleys and/or cams. Shown below are examples of cables that exhibit signs of potential failure. If any of these conditions are apparent, the machine should immediately be taken out of service and repaired. Be sure to use only cables supplied by TRUE Fitness. DO NOT use cables that have fittings attached with hand-crimp tools.

Twisted Cable (Zig-Zag pattern): 	Break in the Cable Cover: 
Break/Bend in Cable: 	Tear in the Cable Cover: 
Stretched Cable Covering: 	Crimp Connector Dislodged: 

CHAPTER 4: CARE & MAINTENANCE

CABLE INSPECTION & MAINTENANCE (CONTINUED):

Cable Tension:

Ensure that the cables are adjusted to remove any slack using the threaded end fittings. These are normally located at the weight stack connection. Depending upon the machine, there may be multiple threaded fittings on multiple cables. You can determine if there is too much slack by performing the exercise. As you start to move a load arm or handle, the weight stack should lift immediately. If not, the cable tension needs to be adjusted.

To adjust the cable tension, loosen the cable nut that is located on the Cable Bolt connected to the Top Plate. Tighten the cable bolt until the top plate is barely lifted off of the first weight plate and then re-tighten the cable nut.

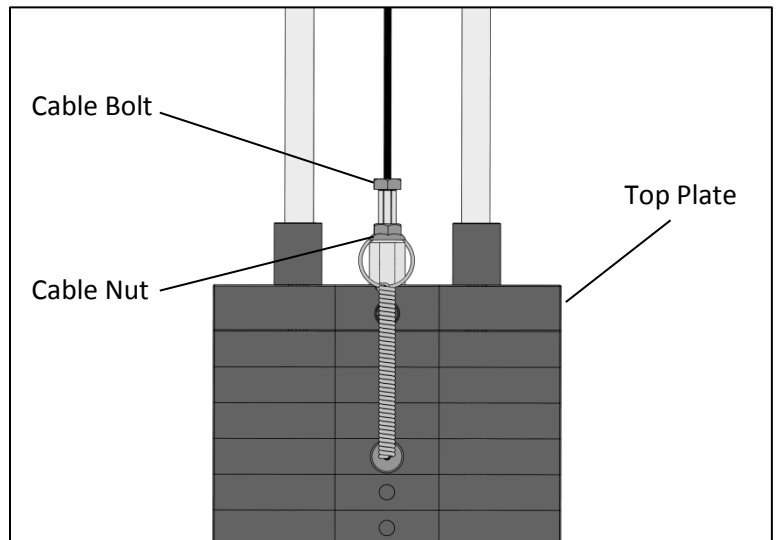

▲ CAUTION:

A minimum of 1/2 inch (12.7mm) of the threaded portion of the cable bolt must be threaded into the top plate.

*No more than 1 inch (25.4mm) of the threaded portion of the cable bolt should be visible.

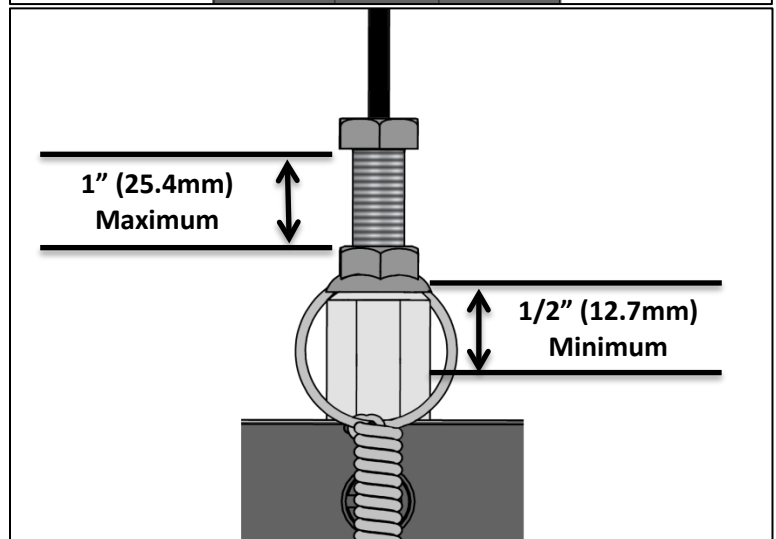

Handle Fittings (if applicable):

Inspect the cable fittings where any handles are attached to the end of the cable. The fittings supplied with this machine are load rated snap-links. Ensure that the snap-link opens and closes easily and is fully engaged when closed. Replace the snap-link as needed.



CHAPTER 5: CUSTOMER SERVICE

CONTACTING SERVICE:

TRUE Fitness recommends that you gather the serial number, model number, and a brief description of the reason for the request. After information has been gathered you may choose to contact your selling dealer or local service company to set an appointment. (If you are not familiar with who is in your area, you may visit our website at www.truefitness.com and use our dealer locator to obtain the contact information for the closest dealer).

You may also contact TRUE Fitness' customer support team by calling 800.883.8783 or e-mailing us at service@truefitness.com Monday – Friday during normal business hours.

TRUE FITNESS SERVICE DEPARTMENT

865 HOFF ROAD

ST. LOUIS, MO 63366

1.800.883.8783

HOURS OF OPERATION: 8:30 A.M. - 5:00 P.M. CST

E-MAIL: service@truefitness.com

CONTACTING SALES:

Interested in TRUE Products? Please contact us with any sales or product inquires so that we may direct you to the appropriate sales representative to answer your questions.

TRUE FITNESS HOME OFFICE

865 HOFF ROAD

ST. LOUIS, MO 63366

1.800.426.6570

HOURS OF OPERATION: 8:30 A.M. - 5:00 P.M. CST

E-MAIL: sales@truefitness.com

CHAPTER 5: CUSTOMER SERVICE

REPORTING FREIGHT OR PARTS DAMAGE:

Unfortunately, sometimes materials can be damaged during shipment. If materials are damaged during shipment, please follow the guidelines below to determine the appropriate process for you to follow in case of damages.

Severe Damage:

Obvious damage to external packaging / internal product. Please **refuse** the shipment and it will be returned to TRUE Fitness by the carrier. Contact the TRUE Fitness customer support team by calling 800.883.8783 or sales support team by calling 800.426.6570 Monday-Friday during normal business hours to notify us that the shipment has been refused. Once we have received the damaged shipment, a replacement shipment will be sent to you. Only refuse the damaged piece if the shipment is multiple boxes.

Slight Damage:

The box may have minimal damages and you are not sure if the actual product is damaged or not. You **must** sign the bill of lading as damaged when accepting the shipment. Once you have opened the box and you have determined something is indeed damaged please gather the serial number, model number, description and photos of damages. Please make sure the photos include the damaged product as well as the damaged box the product arrived in. Contact the TRUE Fitness customer support team by calling 800.883.8783 or sales support team by calling 800.426.6570 Monday-Friday during normal business hours.

Concealed Damage:

You may receive a shipment that looks intact and discover once the box has been opened that there are hidden damages. Please notify the carrier **immediately**. We will not be able to file a claim if the carrier is not notified in a timely manner. Once you have called the carrier you will need to gather the serial number, model number, description and photos of damages. Contact the TRUE Fitness customer support team by calling 800.883.8783 or sales support team by calling 800.426.6570 Monday-Friday during normal business hours.

CHAPTER 6: ADDITIONAL INFORMATION



COMMERCIAL LIMITED WARRANTY FORCE STRENGTH LINE

Save Time and Register Online!
Activate Multiple Warranties at truefitness.com

All TRUE® Fitness products are distributed by TRUE and are warranted to the original registered product purchaser and the parts of the TRUE product (the "Product") listed below, under normal use and service, shall be free of manufacturing defects in workmanship and materials only for the period of time beginning from the original date of purchase set forth below:

Frame*	Lifetime
Parts	
Bearings, Bushings and Weight Plates	5 Years
Guide Rods and Pulleys	5 Years
Cables and Belts	1 Year
Cosmetics, Coatings, Grips and Upholstery	6 Months
Labor	
Frame	1 Year
Bearings, Bushings, Weight Plates	1 Year
Guide Rods and Pulleys	1 Year
Cables and Belts	1 Year
Cosmetics, Coatings, Grips and Upholstery	6 Months

NOTE: Warranty valid for USA and Canada only.
NOTE: Failure to register this product will result in no servicing or authorization of parts to be shipped.
NOTE: Buying after-market products from a 3rd party will result in voided warranty.

Frame: The frame is warranted for defects in material and workmanship for as long as the original purchaser owns the Product. The frame is warranted for labor and freight (for parts shipped from TRUE) for one year from date of purchase. * This limited warranty on structural frame does not include paint or coatings.

Parts: The Force Strength Line's mechanical parts are warranted for defects in material and workmanship for five years with one year labor warranty. Cables and belts are warranted for defects in material and workmanship for one year with one year labor warranty. This limited warranty does not cover damage or equipment failure resulting from or caused by improper assembly/installation, failure to follow instructions and warnings in owner's manual, accident, misuse, abuse, unauthorized modification, or failure to provide reasonable and necessary maintenance.

Cosmetics: The Force Strength Line cosmetic parts, coatings, grips and upholstery are warranted for defects in material and workmanship for six months with labor warranty to match the parts warranty period. This limited warranty does not cover damage or equipment failure resulting from or caused by improper assembly/installation, failure to follow instructions and warnings in owner's manual, accident, misuse, abuse, unauthorized modification, or failure to provide reasonable and necessary maintenance. This limited warranty will apply to but may not be limited to plastic covers, shrouds, caps, badges, overlays, paint, coatings, soft step inserts and grips.

Labor: Labor is covered for a period of one year from the date of purchase unless otherwise expressed within this limited warranty as long as a TRUE authorized service provider performs the service. Service that requires over 50 miles of travel may be subject to additional charges. Reasonable and necessary maintenance guidelines can be found in the owner's manual.

Claims Procedure: TRUE Limited Warranty service may be obtained by contacting the authorized TRUE dealer from whom the Product was purchased. If the dealer from whom the Product was purchased is no longer an authorized TRUE dealer, then TRUE Limited Warranty service may be obtained by contacting TRUE directly at:

TRUE Fitness, Service Department
865 Hoff Road, St. Louis, MO 63366
1.800.883.8783
Hours of operation 8:30am - 5:00 pm CST

truefitness.com / 800.426.6570 / 1.636.272.7100

CHAPTER 6: ADDITIONAL INFORMATION



COMMERCIAL LIMITED WARRANTY FORCE STRENGTH LINE

Save Time and Register Online!
Activate Multiple Warranties at truefitness.com

The above Limited Warranty is subject to and will be in accordance with the conditions set forth below:

1. This Limited Warranty can be processed only if the Warranty Registration Form is completed on-line; or if the attached form is filled in, signed by the original purchaser and mailed to TRUE within 30 days of purchaser's receipt of this Product. The serial number must be intact on the Product for this Limited Warranty to be valid.
2. This Limited Warranty applies to the product only while the Product remains in the possession of the original purchaser and is not transferable.
3. This Limited Warranty becomes VALID ONLY if the Product is initially assembled/installed by a TRUE authorized dealer/ technician (if anyone other than a TRUE authorized dealer/ technician initially assembles and installs the Product, this Limited Warranty will be void unless the written authorization of TRUE is first obtained).
4. This Limited Warranty does not cover damage or equipment failure resulting from or caused by improper assembly/ installation, failure to follow instructions and warnings in owner's manual, accident, misuse, abuse, unauthorized modification, or failure to provide reasonable and necessary maintenance (as referenced in the owner's manual.)
5. This Limited Warranty applies only to the cost of repair or replacement of parts and does not include labor (beyond the above warranty period), transportation, service, return and freight charges associated there with expressly specified herein.
6. This Limited Warranty shall not apply to: Service calls to correct installation of the equipment or instruction to owners on how to use the equipment; or any labor costs incurred beyond the applicable labor warranty period.
7. This Limited Warranty is in lieu of all warranties, express or implied, and in lieu of all other obligations or liabilities on the part of TRUE, under no circumstances shall TRUE be liable by virtue of this Limited Warranty or otherwise from damage to any person or property whatsoever for any special, indirect, incidental, secondary or consequential losses, damages or expenses in connection with exercise products. Any implied warranty is limited in duration to the time period covered by the Limited Warranty. Some states do not allow limitations on how long an implied warranty lasts, or the exclusion may not apply to you. This Limited Warranty grants you specific legal rights and you may also have other rights, which vary from state to state.

NOTE TO AUTHORIZED WARRANTY LABOR PROVIDERS:
Warranty labor reimbursement or warranty parts rights may not be transferred to, reassigned to, a third party without the express written consent of TRUE. Even jobbing out warranty labor requires TRUE's written approval.

FORCE STRENGTH LINE SERIAL NUMBER:

The Force Strength Line comes with one serial number on the base of the machine. Please write down your serial number below and keep for your records.

SERIAL NUMBER:

SAMPLE SERIAL NUMBER STICKER:



Keep this page for your records

CHAPTER 6: ADDITIONAL INFORMATION



COMMERCIAL LIMITED WARRANTY FORCE STRENGTH LINE

Thank you for purchasing a TRUE product. To validate the TRUE product warranty the fast and easy way, please go on-line now to truefitness.com/support and register your product. The information you provide will never be distributed to any other individuals or agencies for any purpose. If you prefer to mail your warranty card, have the owner of the product complete the information below and return it to TRUE Fitness within 30 days from the date of equipment installation.

To mail your warranty information, please fill in the information below and mail to: Service Dept., TRUE Fitness, 865 Hoff Road, St. Louis, MO 63366 (or save postage and register online at truefitness.com)



Commercial Warranty Registration

**PLEASE PROVIDE YOUR SERIAL NUMBER BELOW.
REQUIRED FOR WARRANTY REGISTRATION:**

SERIAL NUMBER:

Model Type _____

Date of Purchase _____

Your Company Name _____

Contact First Name _____

Contact Last Name _____

Address _____

City _____ State _____ ZIP _____

Email Address _____ Website _____

Phone _____ Fax _____

1. Where did you first learn about TRUE?

- a. Dealer b. Website
 c. Advertisement d. Referral
 e. Current Customer f. Other _____

2. Why did you purchase a TRUE product?

- a. Design/Appearance b. Dealer Suggestion
 c. Price/Value d. Quality Construction
 e. Performance f. TRUE Reputation
 g. Other _____

3. Please indicate your type of facility:

- a. Apartment/Condo b. Corporate Fitness Center
 c. Municipality d. Health Club/Gym/Spa
 e. Hotel/Resort f. Military Base
 g. Student Rec Center h. Other

4. What other types of equipment does your company currently own?

- a. Treadmill Brand _____
 b. Bike Brand _____
 c. Elliptical Brand _____
 d. Free Weights/Gym Brand _____

5. How many people use your facility on a daily basis?

- a. <25 b. 25-75
 c. 76-150 d. 150+

6. Do you plan to purchase more fitness equipment in the next 6-12 months?

- Yes No

7. If you answered "yes" to question 6, what type do you plan to purchase?

- a. Treadmill b. Elliptical
 c. Stationary Bike d. Free Weights
 e. Gym f. Other _____

8. Would you recommend TRUE to other club owners?

- Yes No

9. You are a valued TRUE customer and your suggestions allow us to continually improve your experience. Is there anything else you would like us to know? Please explain: