

 **TRUE FITNESS**



APEX CROSS TRAINER

OWNER'S MANUAL AND ASSEMBLY GUIDE

IMPORTANT—PLEASE READ

All products shown are prototype. Actual product delivered may vary. Product specifications, features, and software are subject to change without notice.

For the most up-to-date version of this manual, please see our website: <https://truefitness.com/services-support/user-manuals/>

CONTACTING OUR SUPPORT TEAM

To contact TRUE for any of your pre or post installation questions, please call our toll-free numbers Monday - Friday 8:30am - 5:00pm (CST):

- Commercial Direct Customers and Corporate Accounts | 800.868.8783
- Retail Customers and Distributors | 800.883.8783

Or email us:

- Commercial Direct Customers and Corporate Accounts | service.direct@truefitness.com
- Retail Customers and Distributors | service@truefitness.com
- Service International | int.service@truefitness.com

When contacting TRUE, please have the following information ready:

- Serial Number of Unit
- Contact Information—Full Name, Email, and Phone Number
- Address of Facility or Residence
- Detailed Description Regarding Symptom of the Unit (along with pictures or video if applicable)

NOTE: Authorized service providers, dealers, and distributors may also use TRUE's online resource | portal.truefitness.com.

CONTACTING OUR SALES TEAM

Interested in owning more TRUE products? Please contact us with any product inquires so that we may direct you to the appropriate sales representative to help answer your questions.

- Phone | 800.426.6570
- Email | sales@truefitness.com
- Hours | Monday - Friday 8:30am - 5:00pm (CST)

REPORTING FREIGHT CLAIMS OR PARTS DAMAGE

Unfortunately, sometimes materials can be damaged during shipment. If materials are damaged during shipment, please follow the guidelines below to determine the appropriate process for you to follow.

Severe Damage—Obvious damage to external packaging and internal product.

Please refuse the shipment and it will be returned to TRUE by the carrier. Contact TRUE product support by calling 800.883.8783 or sales support by calling 800.426.6570 Monday–Friday during normal business hours to notify us that the shipment has been refused. Once we have received the damaged shipment, a replacement shipment will be sent to you. If the shipment comes in multiple boxes, only refuse boxes with damage.

Slight Damage—Minimal damage to external packaging with unknown internal damage to product.

If the shipment has minimal damages and you are not sure if the actual product is damaged, you must sign the bill of lading as damaged when accepting the shipment. Once you have opened the box and you have determined something is indeed damaged, please gather the serial number, model number, description of damage, and photos of damage. Please make sure the photos include the damaged product as well as the damaged box the product arrived in. Contact TRUE product support (service@truefitness.com | 800.883.8783) or TRUE sales support (sales@truefitness.com | 800.426.6570) Monday–Friday during normal business hours.

Concealed Damage—No damage to external packaging but internal damage to product.

You may receive a shipment that looks intact and discover once the box has been opened that there are hidden damages. Please notify the carrier immediately. TRUE will not be able to file a claim if the carrier is not notified in a timely manner. Once you have called the carrier you will need to gather the serial number, model number, description of damage, and photos of damage. Contact TRUE product support (service@truefitness.com | 800.883.8783) or TRUE sales support (sales@truefitness.com | 800.426.6570) Monday–Friday during normal business hours.

TABLE OF CONTENTS

SAFETY INSTRUCTIONS

| | |
|--|----|
| IMPORTANT SAFETY INSTRUCTIONS—SAVE THESE INSTRUCTIONS..... | 5 |
| POWER REQUIREMENTS..... | 7 |
| SPACE REQUIREMENTS..... | 8 |
| SPECIFICATIONS..... | 8 |
| WARNING DECALS..... | 9 |
| COMPLIANCES..... | 9 |
| PROPER USE..... | 10 |

ASSEMBLY INSTRUCTIONS

| | |
|----------------------------|----|
| PREASSEMBLY CHECKLIST..... | 11 |
| ASSEMBLY STEPS..... | 14 |

PRODUCT FEATURES

| | |
|-----------------------|----|
| BASE OVERVIEW..... | 25 |
| CONSOLE OVERVIEW..... | 26 |

CARE AND MAINTENANCE

| | |
|-------------------------------|----|
| INSPECTION..... | 28 |
| CLEANING THE EQUIPMENT..... | 28 |
| LEVELING THE MACHINE..... | 28 |
| PREVENTATIVE MAINTENANCE..... | 29 |
| LONG TERM STORAGE..... | 29 |

ADDITIONAL INFORMATION

| | |
|----------------------|----|
| TROUBLESHOOTING..... | 30 |
|----------------------|----|

WARRANTY INFORMATION

| | |
|--------------------------------------|----|
| COMMERCIAL WARRANTY | 32 |
| LIMITED-USE COMMERCIAL WARRANTY..... | 33 |
| IN-HOME USE WARRANTY..... | 33 |
| WARRANTY DETAILS..... | 34 |
| WARRANTY REGISTRATION..... | 35 |

SAFETY INSTRUCTIONS

IMPORTANT SAFETY INSTRUCTIONS—SAVE THESE INSTRUCTIONS

This equipment is intended for a commercial or institutional setting. This owner's manual should be accessible to all personal trainers, faculty, and members.

- Read and understand all instructions and warnings prior to use.
- Obtain a medical exam before beginning any exercise program. If at any time during exercise you feel faint, dizzy, or experience pain, stop and consult your physician.
- Obtain proper instruction prior to use.
- This unit is intended for commercial use only.
- Inspect the unit for incorrect, worn, or loose components and do not use until corrected, replaced, or tightened prior to use.
- Do not wear loose or dangling clothing while using the unit.
- Care should be used when mounting or dismounting the unit.
- Read, understand, and test the emergency stop procedures before use.
- Disconnect all power before servicing the unit.
- Do not exceed maximum user weight of 400 lbs / 181 kg.
- Keep the top side of the moving surface clean and dry.
- Keep children and animals away.
- Use caution when moving and assembling unit.
- All exercise equipment is potentially hazardous. If attention is not paid to the conditions of equipment usage, death, or serious injury could occur.

⚠ WARNING: To reduce the risk of burns, fire, and electric shock or injury to persons, follow these instructions:

- Heart rate monitoring systems may be inaccurate. Over-exercising may result in serious injury or death. If you feel faint, dizzy, or experience pain, stop exercising immediately.
- Health related injuries may result from incorrect or excessive use of exercise equipment.
- TRUE STRONGLY recommends seeing a physician for a complete medical exam before undertaking an exercise program, particularly if the user has a family history of high blood pressure or heart disease, is over the age of 45, smokes, has high cholesterol, is obese or has not exercised regularly in the past year. Additionally, TRUE recommends consulting a fitness professional on the correct use of this product.
- Equipment should be immediately taken out of use if it fails to work properly or when a warning is presented electronically.
- When using this exercise machine, basic precautions should always be followed.
- Use this equipment only for its intended use as described in this manual.
- Do not move the equipment by lifting the console. Do not use the console as a handlebar during a workout.
- This product can expose you to chemicals including Toluene and Acrylamide which are known to the State of California to cause Cancer and birth defects or other reproductive harm. For more information, go to www.P65Warnings.ca.gov.
- Keep equipment stable on flat ground.
- Risk of personal injury—crushing hazard when equipment is in operation. Keep feet, hands, and fingers away from moving parts.
- Replace warning labels that may be worn, damaged, or missing.
- Replace any non-working or damaged components, remove the unit from service until repair is performed.
- Do not operate the equipment while being covered with a blanket, pillow, plastic, or anything that insulates or stops airflow. Keep air openings free of lint, hair or any obstructing material.
- Any changes or modifications to this equipment could void the product warranty.
- Do not use this product in areas where aerosol spray products are being used or where oxygen is being administered. Such substances create the danger of combustion and explosion.
- Do not use this product outdoors, near water, while wet, or in areas of high humidity including extreme temperature changes.
- Close supervision is necessary when used near children under the age of 15, or disabled persons.

- Wear shoes with rubber or high traction soles. Do not use shoes with heels, leather soles, cleats or spikes. Make sure no stones are embedded in the soles. Do not use this product in bare feet. Keep all loose clothing, shoelaces and towels away from moving parts.
- Use upper exercise arms to maintain balance when mounting and dismounting the machine and for additional stability while exercising.
- Avoid the possibility of bystanders being struck or caught between moving parts by making sure that they are out of reach of the equipment while it is in motion.
- Do not use typing or web surfing features at excessive speeds. Always stabilize yourself when using typing or web surfing features. (Varies by console option.)
- Never place liquids of any type directly on the unit except in the accessory tray or bottle holders. Containers with lids are recommended.
- Always follow the console instructions for proper operation.
- Use correct ergonomic positioning while operating this equipment.
- Allow only one person at a time on the equipment while it's operating.
- Do not allow animals on or near the equipment while in operation.
- Do not reach into or underneath the unit, or tip it on its side during operation.
- Do not use if you have a cold or fever.
- This equipment is not intended for use by persons with reduced physical, sensory, or mental capabilities, or lack of experience and knowledge, unless they are supervised or have been given instruction concerning use of the equipment by a person responsible for their safety.
- Children shall not play with the appliance.
- Cleaning and user maintenance shall not be made by children without supervision.
- Do not use attachments not recommended by the manufacturer.
- Allow only trained personnel to service this equipment.
- It is the sole responsibility of the owner/operator to ensure regular and scheduled maintenance is performed.
- This machine is self-generated and does not require the use of an electrical outlet with the LED console. Optional touch screen or PVS consoles require 110V AC input and 9V DC 1.5 amp output for console operation only.
- The batteries within self-generated equipment contain materials that are considered hazardous to the environment. Federal law requires proper disposal of these batteries.

⚠ DANGER: To reduce the risk of electric shock, always unplug this product when not in use, before cleaning, or attempting any maintenance activity. Do not handle the plug with wet hands.

- To disconnect, turn power OFF at the ON/OFF switch if applicable, then remove plug from electrical outlet.
- Use a TRUE AC power cord.
- Position this product so the power cord plug is accessible to the user.
- Keep the power cord away from heated surfaces. Do not pull the equipment by the power cord or use the cord as a handle. Do not run the power cord along the side or under the equipment.
- If the electrical supply cord is damaged it must be replaced by the manufacturer, an authorized service agent, or a similarly qualified person to avoid a hazard.
- This product must be connected to a properly grounded electrical outlet.
- Never insert objects into any openings in this product. If an object should drop inside, turn off the power, unplug the power cord from the outlet and carefully retrieve it. If the item cannot be reached, contact TRUE product support.
- To avoid serious injury, remove and store the power cord when the machine is not in use.
- This appliance should never be left unattended when plugged in.
- Do not use any type of extension cord with this product.
- Never operate a TRUE product if it has a damaged power cord or electrical plug, or if it has been dropped, damaged, or even partially immersed in water.

NOTE: Power warnings, grounding instructions, and power requirements are only applicable when this product is being used with the optional power supply. Non-LED consoles require the optional power supply.

POWER REQUIREMENTS

Read and understand all instructions before plugging any TRUE power cord into an electrical outlet.

DEDICATED LINE

This product does not require a dedicated line.

GROUNDING INSTRUCTIONS



This product must be grounded. If the product malfunctions or breakdowns, grounding provides a path of least resistance for electric current to reduce the risk of electric shock. This product is equipped with a cord having an equipment grounding conductor and a grounding plug. The plug must be plugged into an appropriate outlet that is properly installed and grounded in accordance with all local codes and ordinances.

▲ DANGER:

- Improper connection of the equipment grounding conductor can result in risk of electrical shock.
- Check with a qualified electrician or service provider if you are in doubt as to whether the equipment is properly grounded or installed on a dedicated line.
- Seek a qualified electrician to perform any modifications to the cord or plug. TRUE is not responsible for injuries or damages as a result of cord or plug modification.

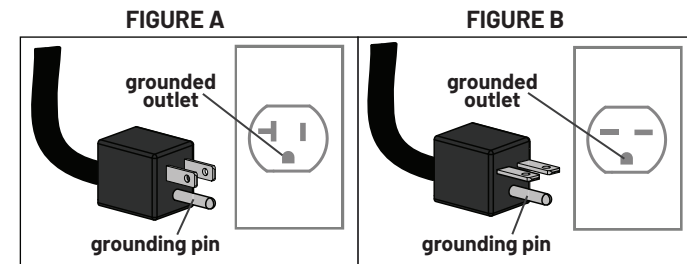
- To reduce the risk of burns, fire, electric shock, or injury, it is imperative to connect each product to a properly grounded 110V or 220V electrical outlet. The voltage required for your unit is located on the serial number decal (usually on the front of the unit). Depending on where you live voltage requirements differ.
- Some TRUE products require a circuit rated 110V, 60 Hz, and 20 amps. In the United States, most residential homes have circuits rated 110V, 60 Hz, and 15 amps. If your unit requires a 20 amp outlet, contact an electrician to install a dedicated 20 amp circuit prior to use.
- **110 Volt**—This model is for use on a nominal 110V circuit and has a grounding plug that looks like the plug illustrated in figure A. Make sure the product is connected to an outlet having the same configuration as the plug. No adapter should be used with this product.
- **220 Volt**—This model is for use on a circuit having a nominal rating no less than 208V and more than 240V and is factory equipped with a specific electric cord and has a grounding plug that looks like the plug illustrated in figure B. Make sure that the product is connected to an outlet having the same configuration as the plug in figure B. No adapter should be used with this product. If the product must be reconnected for use on a different type of electric circuit, the reconnection should be made by qualified service personnel.



| Power Information | | | | | | |
|-------------------|------------------|----------------|----------------------|--|--|------------------------------|
| Model | Line Voltage (V) | Frequency (Hz) | Rated Current (Amps) | Number of Units per Circuit | Plug/Outlet | Max Power Dissipation (Watt) |
| XC1-XA-35 | 110 | 50/60Hz | 20 | Up to 3 cross trainers per circuit—DO NOT exceed | NEMA 5-20  | 550 watts per cross trainer |
| | 220 | 50/60Hz | 8 | Up to 3 cross trainers per circuit—DO NOT exceed | NEMA 6-15  | 550 watts per cross trainer |

NOTES:

- The plug configuration for the power adapter may vary by country.
- Power warnings, grounding instructions, and power requirements are only applicable when this product is being used with the optional power supply. Non-LED consoles require the optional power supply.

SPACE REQUIREMENTS

TRUE recommends leaving a minimum of 24" (61cm) on each side of the equipment and a 39" (99cm) safety zone at the rear of the equipment.

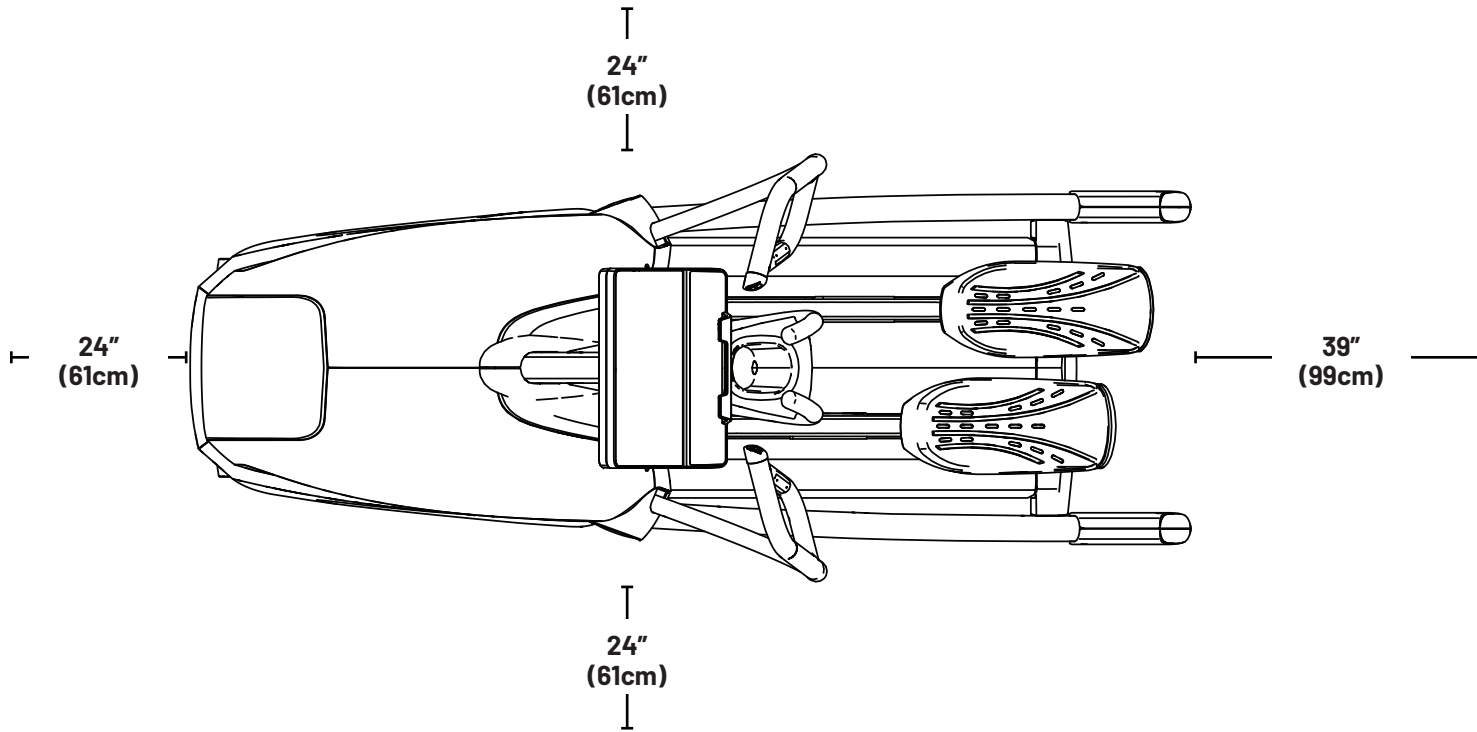

SPECIFICATIONS

- **DIMENSIONS (L X W X H)**

- **Footprint**

- 63" x 32" x 64" (160cm x 81cm x 163cm)

- **Active Footprint**

- 74" x 32" x 64" (188cm x 81cm x 163cm)

- **MACHINE WEIGHT**

- 364 lbs / 165 kg

- **MAXIMUM USER WEIGHT**

- 400 lbs / 181 kg

WARNING DECALS

⚠ WARNING: Replace warning labels that may be worn, damaged, or missing.

To replace any worn or missing decals contact TRUE product support (service@truefitness.com | 800.883.8783).



console serial
number location



base serial
number location



COMPLIANCES

This equipment complies with all applicable codes and regulations. For a complete list of compliances, please visit www.truefitness.com.

PROPER USE

PROPER TRAINING POSITION

- Users should keep both feet on the pedals (A) during the workout.
- During a workout the user's hand should grasp the upper exercise arms (B) or stationary handlebars (C).
- Users should remain standing throughout the workout.

ENTRY AND EXIT SAFETY

To Enter:

- Step up onto the side platforms (if equipped).
- Grip the upper exercise arms for stability while stepping onto the lowest pedal.
- Place opposite foot onto the other pedal.

To Exit:

- Stop pedaling by slowing leg motion and applying slight resistance to the upper exercise arms.
- While gripping the upper exercise arms for stability, step from the highest pedal onto the side platform (if equipped).
- Place the opposite foot on the other side platform (if equipped).
- Step down to the floor.



ASSEMBLY INSTRUCTIONS

 **NOTE:** Supplemental video available @TRUEFitnessservicevids: https://www.youtube.com/playlist?list=PLr3lgv32UrupfqchaypIG13susf3wJ-k_

PREASSEMBLY CHECKLIST

BASIC GUIDELINES FOR SETTING UP THE EQUIPMENT

After removing the equipment from the packaging, place the equipment on a clean, level surface. Make sure the electrical cord easily reaches a grounded three-pronged outlet.

⚠ DANGER: Do not use an extension cord or ungrounded outlet. The ground helps prevent electrical damage to your equipment and enhances your safety by helping to prevent shock. Check with a qualified electrician or serviceman if you are in doubt as to whether the equipment is properly grounded. Do not modify the plug provided with the unit if it will not fit the outlet. Have a proper outlet installed by a qualified electrician.

⚠ CAUTION:





Use caution when assembling this product.
Unpacking and assembling of this product is a two person task.





Use caution when unpacking this product. Avoid damage to the product.
DO NOT use a box cutter. DO NOT slice into the packaging.

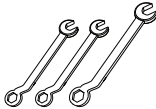

Avoid damage to the product.
NEVER use an electric screwdriver to fasten the plastic shroud pieces.

| TOOLS NEEDED FOR ASSEMBLY | | INCLUDED IN BOX |
|---|---|-----------------|
| #2 Phillips Screwdriver |  | NO |
| 6mm Allen Wrench |  | YES |
| Ratchet Wrench with 6mm Socket Bit and Extension (optional but recommended) |  | NO |

| TOOLS NEEDED FOR ASSEMBLY | | INCLUDED IN BOX |
|------------------------------|---|-----------------|
| 13mm (Qty 2) and 17mm Wrench |  | NO |
| Rubber Mallet |  | NO |
| Wire Cutters |  | NO |

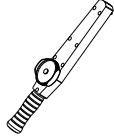
| TOOLS NEEDED FOR ASSEMBLY | | INCLUDED IN BOX |
|--|---|-----------------|
| Torque Wrench (optional but recommended) |  | NO |

VERIFY BOX CONTENTS

IMPORTANT! Please verify box contents. If you have questions, or if there are any missing parts, contact product support (service@truefitness.com | 800.883.8783).

BOX CONTENTS

| ITEM | DESCRIPTION | QTY |
|------|------------------------|-----|
| 1 | Base | 1 |
| 2 | Console Mast | 1 |
| 3 | Left Moving Handlebar | 1 |
| 4 | Right Moving Handlebar | 1 |
| 5 | Left Pedal | 1 |
| 6 | Top Tray | 1 |
| 7 | Top Front Shroud * | 1 |
| 8 | Left Front Shroud * | 1 |
| 9 | Right Front Shroud | 1 |
| 10 | Left Handlebar Cover | 1 |
| 11 | Right Handlebar Cover | 1 |
| 12 | Mast Boot | 1 |
| 13 | Left End Caps | 2 |
| 14 | Right End Caps | 2 |
| 15 | Battery | 1 |
| 16 | Hardware Bag | 1 |
| 17 | Manual | 1 |

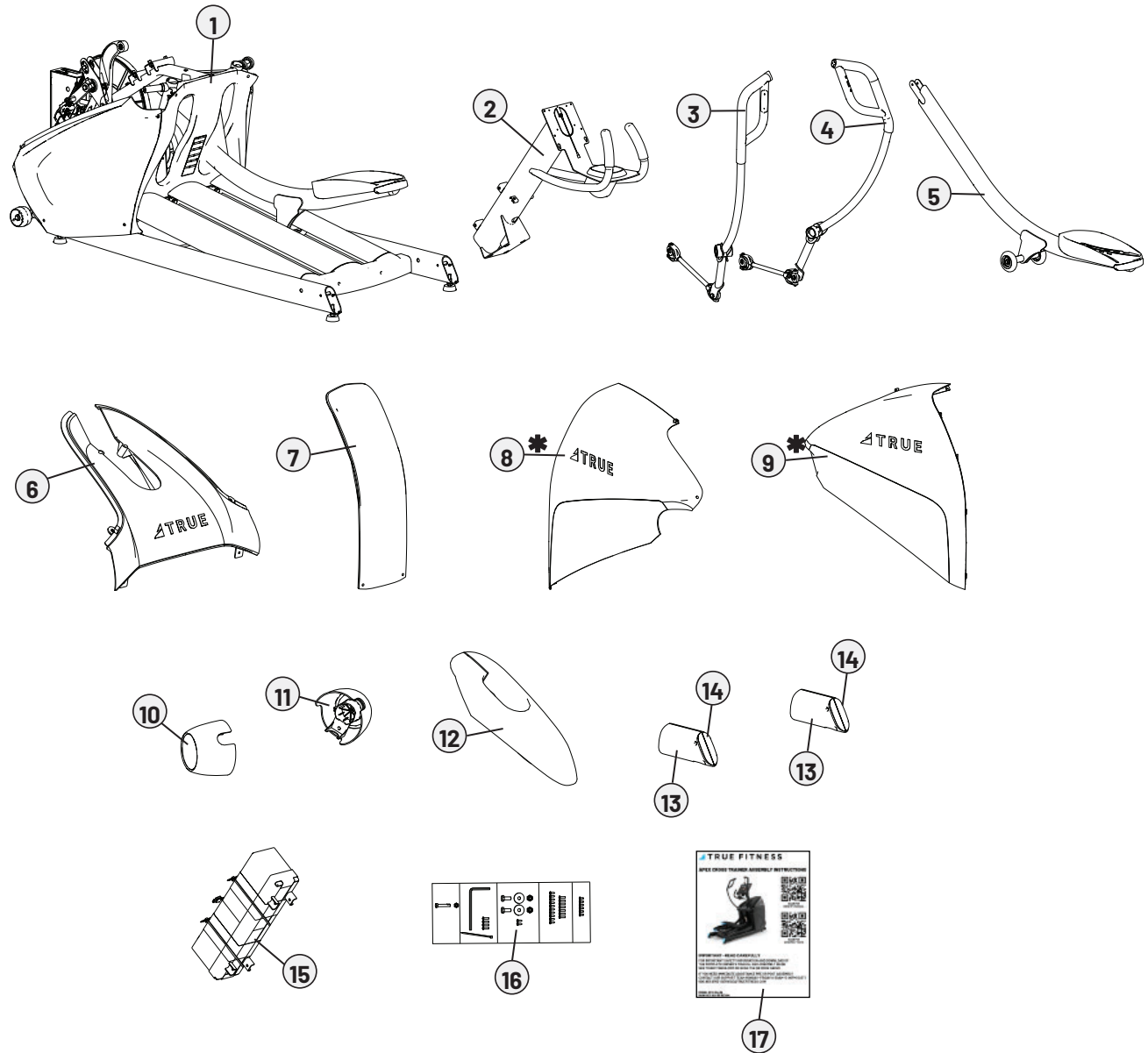

* Keep protective coverings on the shrouds until step 6.

HARDWARE PACK CONTENTS

| 111306-001 HARDWARE PACK | | | |
|--------------------------|-------------|--|-----|
| ITEM | PART NUMBER | DESCRIPTION | QTY |
| 1 | 102134-001 | SCREW, M5 X 0.8 X 18, PAN HEAD, TYPE 1 CROSS RECESSED, SS | 11 |
| 2 | 100429-001 | SCREW, M4.8 X 1.6 X 13 TYPE B, TYPE 1 CROSS RECESS PAN HEAD, ST BZ | 12 |
| 3 | 102135-001 | SCREW, M5 X 0.8 X 10, PAN HEAD, TYPE 1 CROSS RECESSED, SS | 6 |
| 4 | 106618-001 | BOLT, M10 X 1.5 X 25, HEX HEAD, CLASS 10.9 | 2 |
| 5 | 108512-001 | WASHER, 10 X 35 X 2, STEEL, YZ | 2 |
| 6 | 103395-001 | NUT, HEX, NYLON INSERT, M10 X 1.5, CZ CLASS 10 | 2 |
| 7 | 105709-001 | BOLT, M8 X 1.25 X 45 HCS, 12.9 STL, CZ | 1 |
| 8 | 103393-001 | NUT, HEX, NYLON INSERT, M8 X 1.25, CZ CLASS 10 | 1 |
| 9 | 100924-001 | WRENCH, HEX, M6 | 1 |
| 10 | 107023-001 | TIE, CABLE, W3.6 X L370 | 1 |

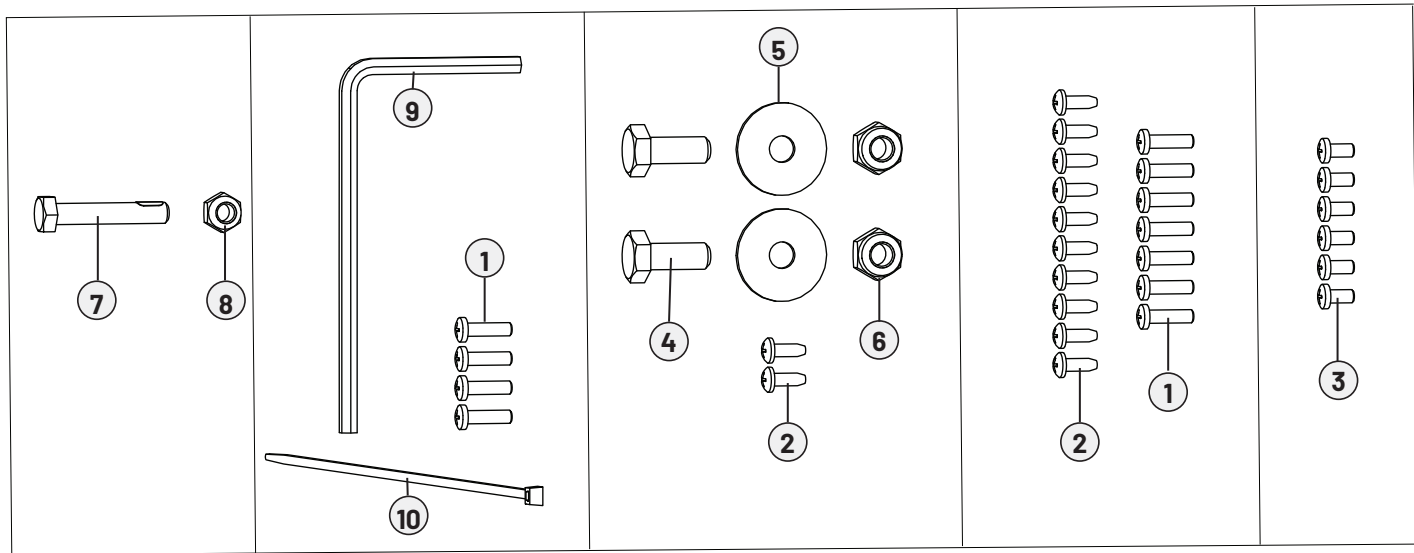

ASSEMBLY STEPS

Step 1—Attach the Left Pedal Lever

| Tools Used in this Step | |
|--------------------------|---|
| 13mm Wrenches (qty 2) |  |

| Parts Used in this Step | | | |
|-------------------------|------------|--|-----|
| Item | Part | Description | Qty |
| 1 | 8100083 | ASSEMBLY, TRACKS PEDAL LEVER, BLACK | 1 |
| 2 | 108911-001 | ASSY, 3P LINK, 20-28 STRIDE, LH | 1 |
| 3 | 8100092 | ASSEMBLY, TRACK COVER, BLACK | 1 |
| 4 | 8100094 | ASSEMBLY, TRACK COVER, CENTER, BLACK | 1 |
| 5 | 8100091 | ASSEMBLY, TRACK COVER, BLACK | 1 |
| 6 | 105709-001 | BOLT, M8 X 1.25 X 45 HCS, 12.9 STL, CZ | 1 |
| 7 | 103393-001 | NUT, HEX, NYLON INSERT, M8 X 1.25, CZ CLASS 10 | 1 |

A. Remove and set aside the track covers.

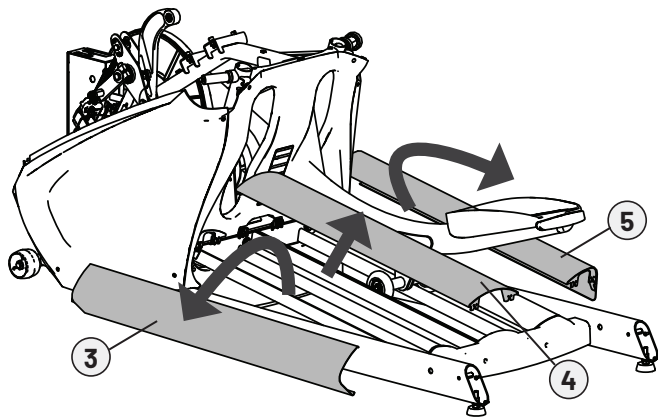



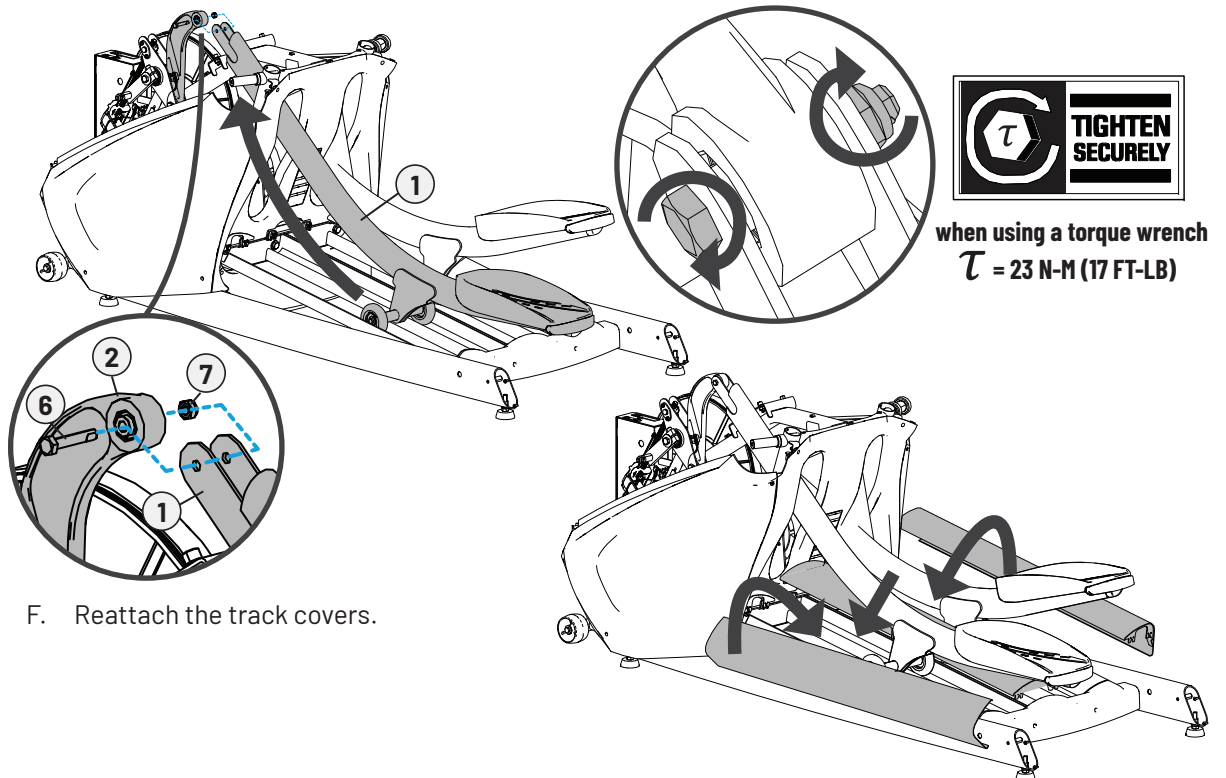

B. Remove any protective coverings and verify the tracks and wheels are clean and free from debris.

- C. Set the left pedal roller wheels on the tracks and slide the pedal up through the upper rear shroud.
- D. Attach the left pedal lever to the 3-pivot link using the bolt and nut.
- E. Using two 13mm wrenches, securely fasten the hardware. When using a torque wrench fasten to 23 n-m (17 ft-lb).



F. Reattach the track covers.

Step 2—Attach the Console Mast and Battery

| Tools Used in this Step | |
|---|---|
| 6mm Allen Wrench |  |
| Ratchet Wrench with 6mm Socket Bit and Extension (optional but recommended) |  |
| #2 Phillips Screwdriver |  |
| Wire Cutters |  |

| Parts Used in this Step | | | |
|-------------------------|------------|--|-----|
| Item | Part | Description | Qty |
| 1 | 8100073 | ASSEMBLY, MAST, XT-4700, BLACK | 1 |
| 2 | 101295-001 | SCREW, M8 X 1.25 X 20.0L SHCS, BLACK ZINC, 12.9 STL | 4 |
| 3 | 109653-001 | ASSY, BATTERY PACK | 1 |
| 4 | 102134-001 | SCREW, M5 X 0.8, PAN HEAD, TYPE 1 CROSS RECESSED, SS | 4 |
| 5 | 107023-001 | TIE, CABLE, W3.6 X L370 | 1 |

- Remove the twist ties securing the cables to the base frame and drape the cables off to the side.
- Slide console mast onto the four screws on the base frame.

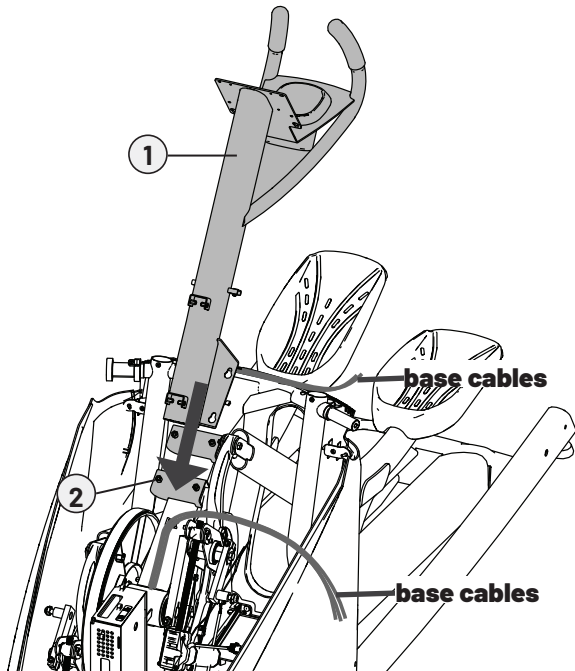

- Using the front hole on the console mast and the large opening at the base of the console mast, route the cables up through the console mast.

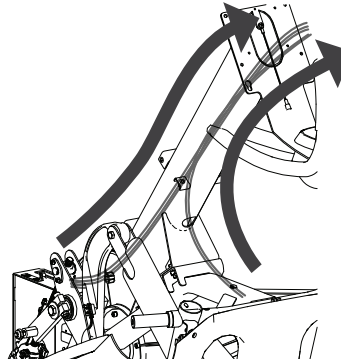

NOTE: If needed, use the previously removed wire ties as fishing wire to help pull the cable bundle up and out the top of the mast.

- Securely fasten the four console mast socket head cap screws. When using a torque wrench fasten to 23 n-m (17 ft-lb).

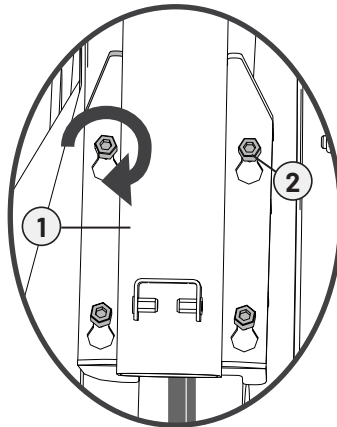

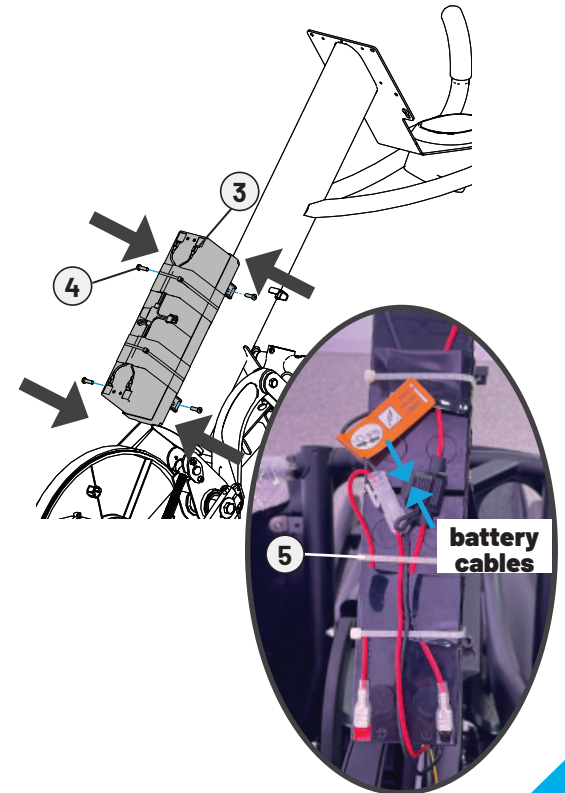

when using a torque wrench
 $\tau = 23 \text{ N-M (17 FT-LB)}$

- Attach the battery to the four brackets on the console mast.
- Secure in place with four Phillips screws.
- Connect the white 2-pin base and battery cables and secure the base cable to the battery with cable tie. Snip excess cable tie material.



Step 3—Attach Moving Handlebars and Connect Handlebar Cables

| Tools Used in this Step | |
|-------------------------|---|
| 17mm Wrench |  |
| Rubber Mallet |  |
| #2 Phillips Screwdriver |  |

- A. Remove the protective wrapping from the left handlebar shaft.
- NOTE:** Wrapping is greasy.
- B. Slide the left moving handlebar over the left shaft on the base and then slide the moving arm end link over the small crank arm.

NOTE: You might need a rubber mallet to lightly tap the arm on to the shaft.

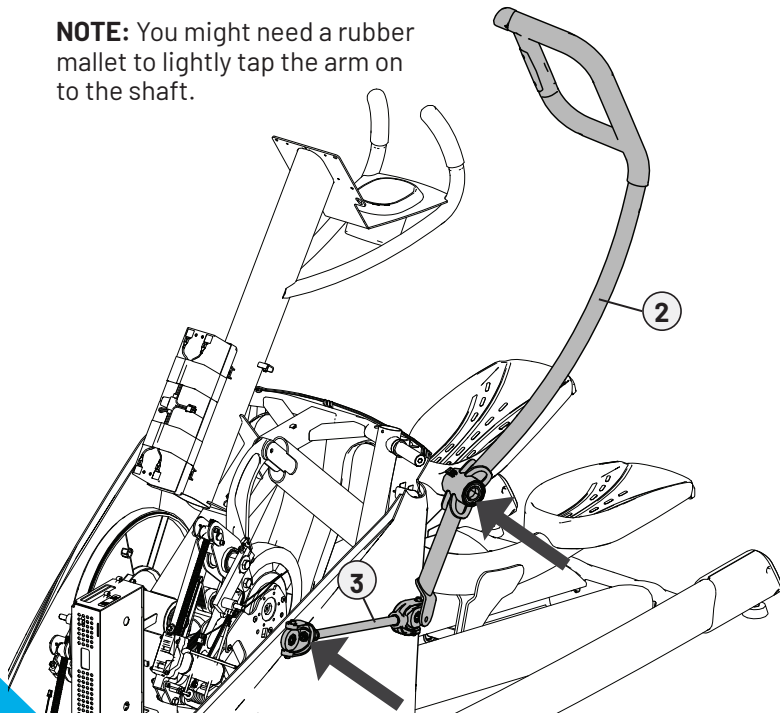

| Parts Used in this Step | | | |
|-------------------------|------------|--|-----|
| Item | Part | Description | Qty |
| 1 | 8100086 | ASSEMBLY, MULTI-GRIP, RH, BLACK | 1 |
| 2 | 8100090 | ASSEMBLY, MULTI-GRIP, LH, BLACK | 1 |
| 3 | 108942-001 | ASSY, MOVING ARM LINK | 2 |
| 4 | 106618-001 | BOLT, M10 X 1.5 X 25, HEX HEAD, CLASS 10.9 | 2 |
| 5 | 108512-001 | WASHER, 10 X 35 X 2, STEEL, YZ | 2 |
| 6 | 103395-001 | NUT, HEX, NYLON INSERT, M10 X 1.5, CZ CLASS 10 | 2 |
| 7 | 100429-001 | SCREW, M4.8 X 1.6 X 13 TYPE B, TYPE 1 CROSS RECESS PAN HEAD, ST BZ | 2 |

- C. Attach the moving handlebar to the shaft with an M10 washer and M10 bolt. Attach the moving arm link to the small crank arm with an M10 nut. Securely fasten all hardware. When using a torque wrench fasten to 45 n-m (33 ft-lb).

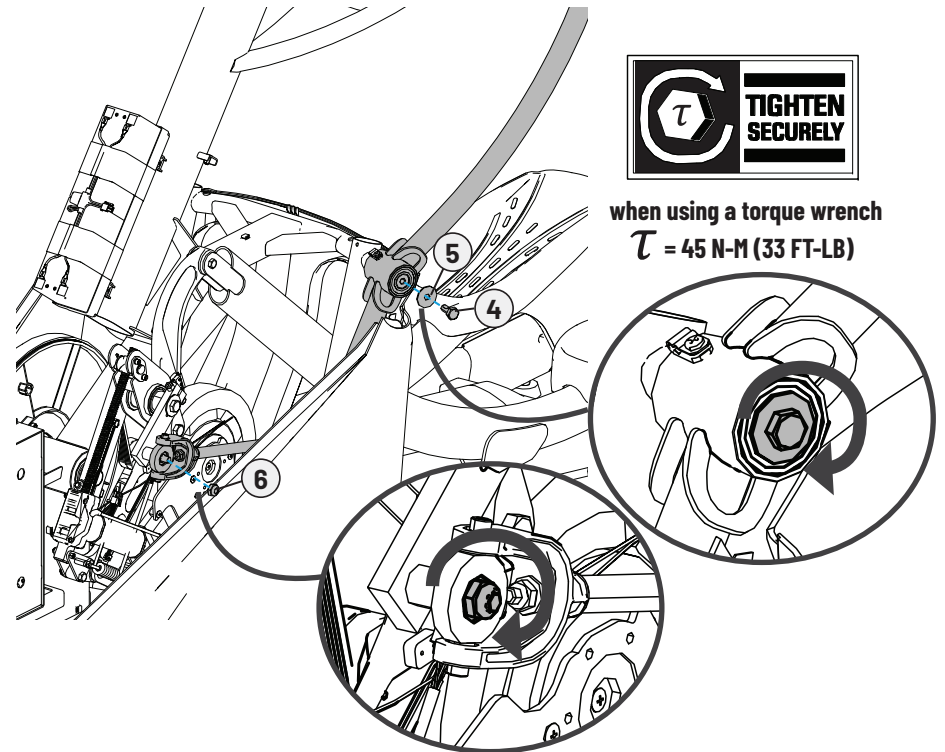

Step 3—Attach Moving Handlebars and Connect Handlebar Cables Continued

- D. Hook the plastic clip on the left moving handlebar cables over the hole in the frame.

Secure with an M4 screw.

Connect the left moving arm cables to the cables in the base.

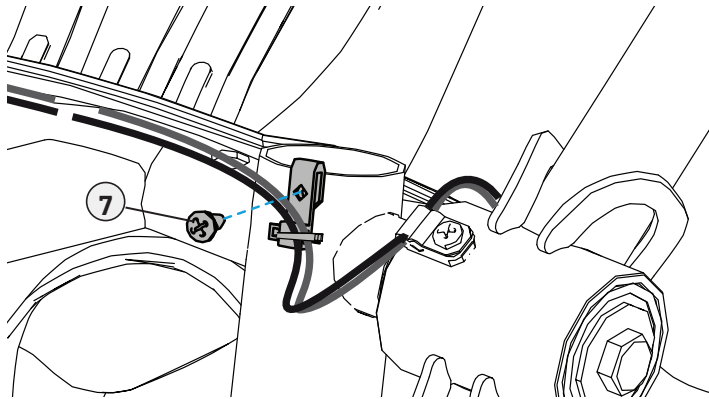

- E. Repeat steps A-D for the right moving handlebar.

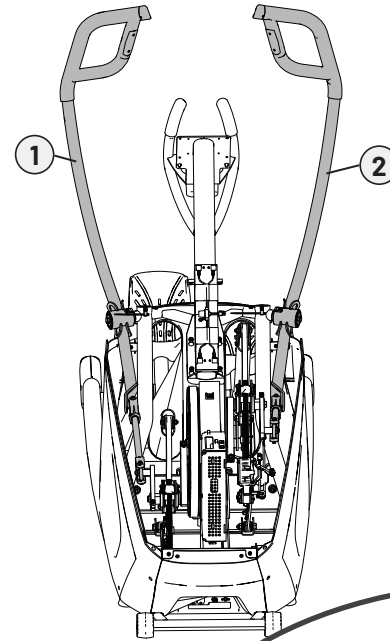

Step 4—Attach Top Tray and Handlebar Covers

Tools Used in this Step

#2 Phillips
Screwdriver



Parts Used in this Step

| Item | Part | Description | Qty |
|------|------------|---|-----|
| 1 | 8100066 | ASSEMBLY, TRAY SHROUD, BLACK | 1 |
| 2 | 8100095 | ASSEMBLY, SHROUD, ARM PIVOT, RH, BLACK | 1 |
| 3 | 8100097 | ASSEMBLY, SHROUD, ARM PIVOT, LH, BLACK | 1 |
| 4 | 102134-001 | SCREW, M5 X 0.8 X 18, PAN HEAD, TYPE 1 CROSS RECESSED, SS | 4 |

- A. Line up the slot of the left handlebar cover with the left moving handlebar and press into place.

NOTE: Handlebar covers are labeled L and R for left and right.

Repeat for the right moving handlebar cover.

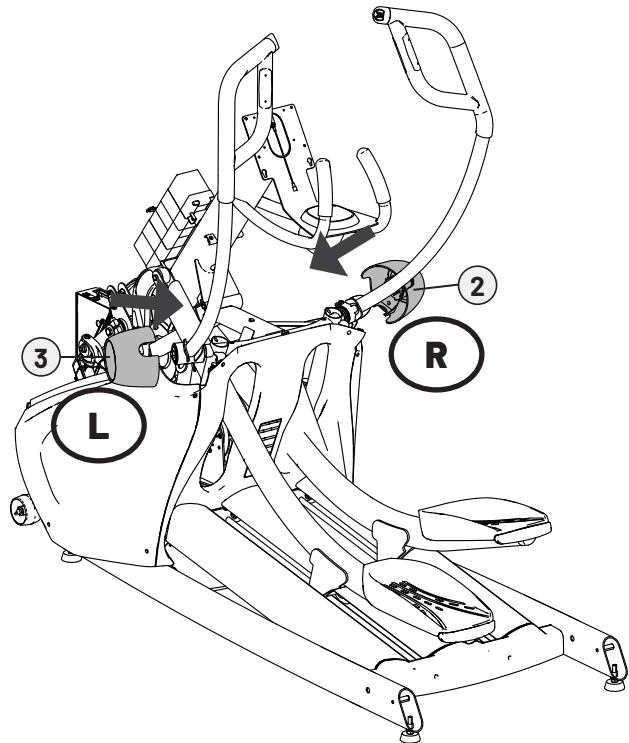

- B. Using a #2 Phillips screwdriver, remove and set aside the two screws at the top of the back shroud.

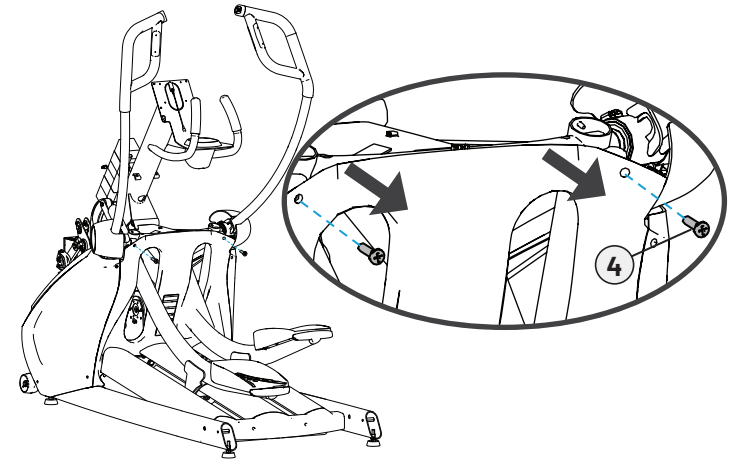

- C. Position the top tray shroud over the base frame and around the console mast. Using a #2 Phillips screwdriver, fasten to the frame using two M5 screws from the hardware pack, and then fasten to the back shroud using the two previously removed M5 screws.

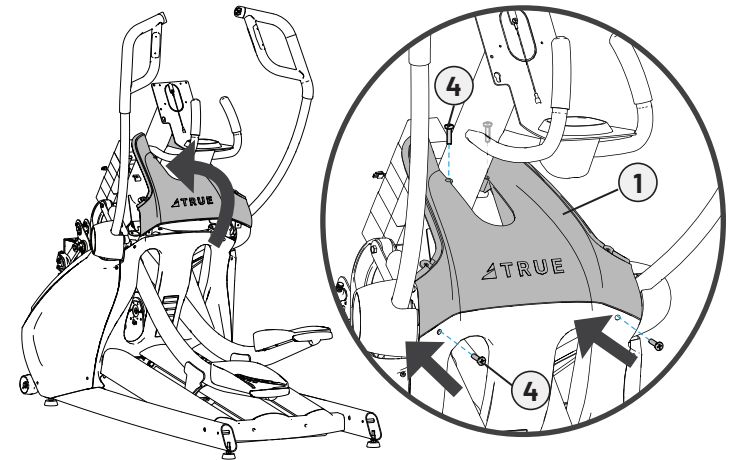

Step 5—Attach Console and Connect Power Cord (if applicable)

| Tools Used in this Step | |
|-------------------------|---|
| #2 Phillips Screwdriver |  |

| Parts Used in this Step | | | |
|-------------------------|---------|---|-----|
| Item | Part | Description | Qty |
| 1 | N/A | CONSOLE MAST ASSEMBLY | 1 |
| 2 | N/A | CONSOLE | 1 |
| 3 | 8027026 | POWER SUPPLY, 12VDC 12.5A UNIVERSAL INPUT | 1 |

- A. If the console has three screws (00567700 // SCREW, M4-.7 X 12 PPHMS SEMS) preassembled, remove and set aside these screws. They are not used in this installation. Remove and set aside the top two screws (00567800 // SCREW, M5-.8X12 COMBO PHILLIPS/COMMON TRUSS HEAD - ACG BLACK) preassembled to the console. Slightly loosen the bottom two screws but leave them installed. All four screws will be used to secure the console to the mast in step C.

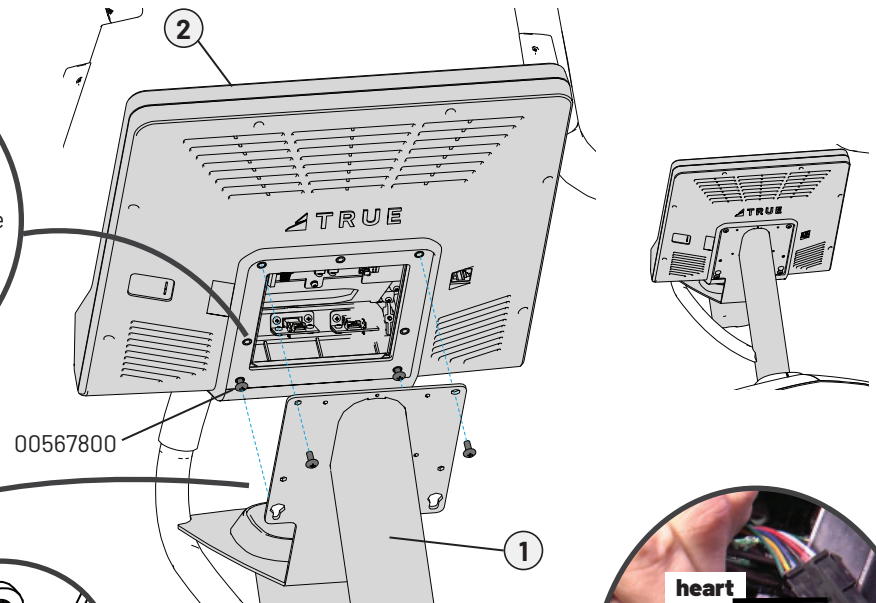
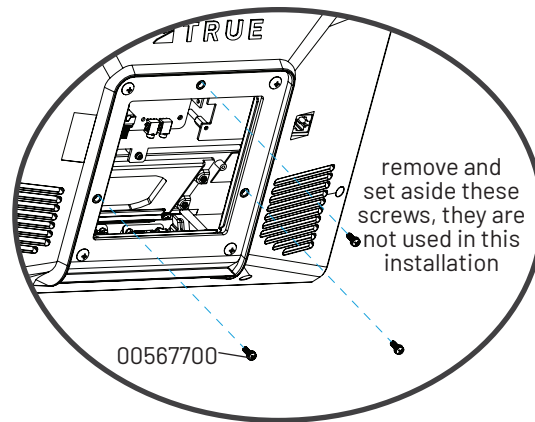

- B. Connect the console and base cables: heart rate, coaxial, button control, I/O data, network, power, and ground.

NOTE: The LED console does not use the coaxial or network cables. Those cables can be tucked back down the console mast.

Ensure all cables are routed inside the console mast to avoid pinching the cables

- C. Using a #2 Phillips screwdriver, secure the console to the console mast using the four screws (00567800).

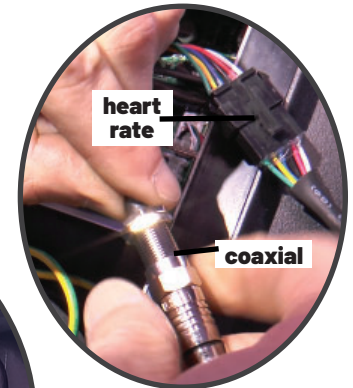
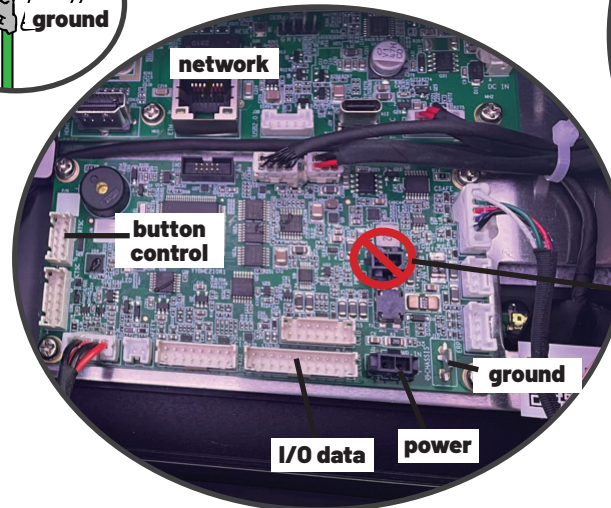
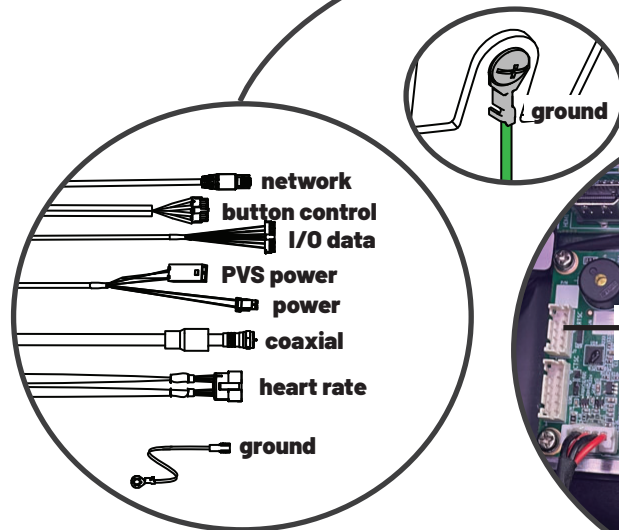

NOTE: Depending on the installation, PVS power may not be used.

Step 5—Attach Console and Connect Power Cord (if applicable) Continued

D. Connect the power supply if using a touch screen or PVS console.

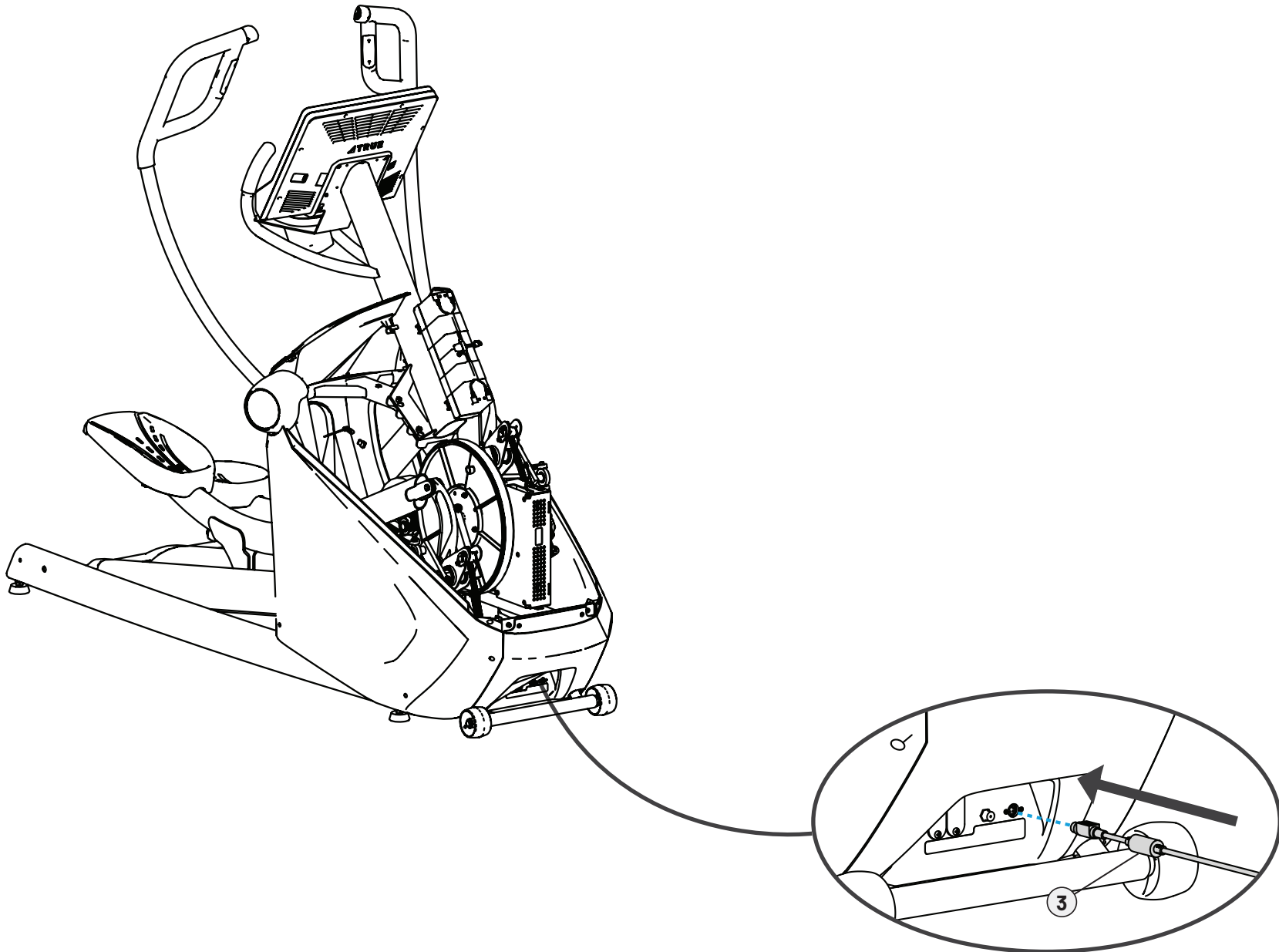

Step 6—Assemble and Attach Shrouds

| Tools Used in this Step | |
|-------------------------|---|
| #2 Phillips Screwdriver |  |

NOTE: Before you begin, make sure you have a soft surface, or use the cardboard from the packaging, to lay the shroud pieces on. Also note that the shrouds are stamped with an R and L for right and left.

| Parts Used in this Step | | | |
|-------------------------|------------|--|-----|
| Item | Part | Description | Qty |
| 1 | 8100064 | ASSEMBLY, TOP SHROUD, LABEL RIGHT, BLACK | 1 |
| 2 | 8100070 | ASSEMBLY, TOP SHROUD, LABEL, LEFT, BLACK | 1 |
| 3 | 8100071 | SHROUD, ACCENT PANEL, RIGHT, BLACK | 1 |
| 4 | 8100072 | SHROUD, ACCENT PANEL, LEFT, BLACK | 1 |
| 5 | 8100061 | SHROUD, FRONT, BLACK | 1 |
| 6 | 100429-001 | SCREW, M4.8 X 1.6 X 13 TYPE B, TYPE 1 CROSS RECESS PAN HEAD, ST BZ | 10 |
| 7 | 102134-001 | SCREW, M5 X 0.8 X 18, PAN HEAD, TYPE 1 CROSS RECESSED, SS | 5 |

- A. Align the center front shroud to the right shroud assembly. Insert two M4 screws into top and bottom holes as indicated. Make sure center front shroud sits in groove of right shroud assembly; tighten screws. Insert three M4 screws into remaining holes and tighten.

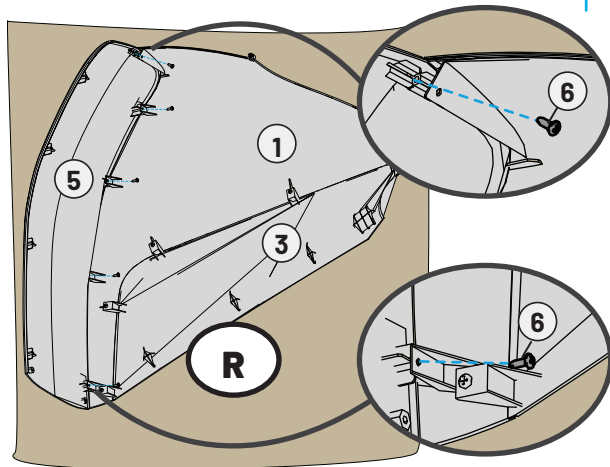

- B. Align the left shroud assembly to the front/right shroud assembly. Insert two M4 screws into top and bottom holes as indicated. Make sure center front shroud sits in groove of left shroud assembly; tighten screws. Insert three M4 screws into remaining holes and tighten.

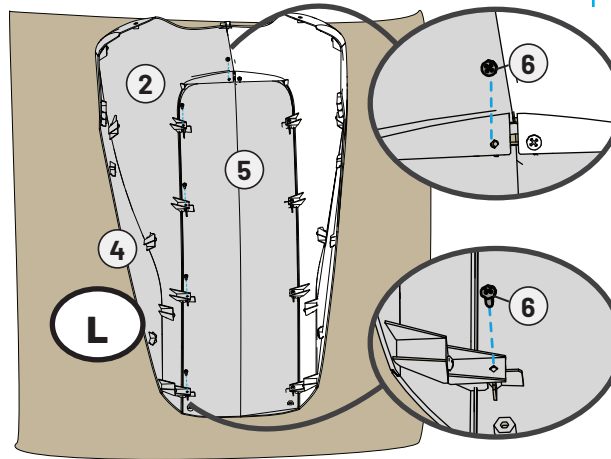

- C. Insert one M5 screw into the center hole of the left and right shroud assemblies and tighten.

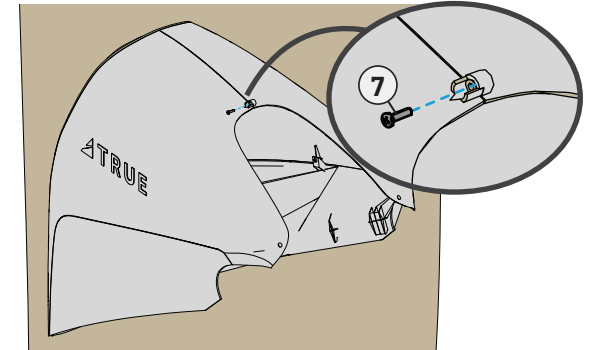

- D. Position the shroud assembly on base frame. Insert and tighten four M5 screws to secure the shrouds in place.

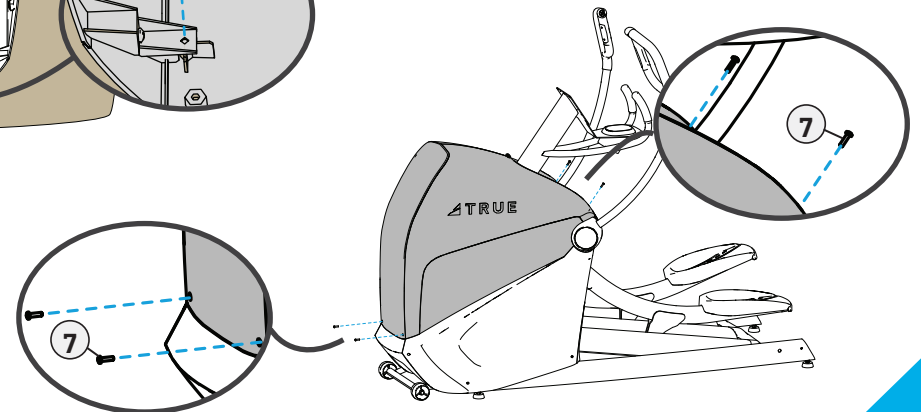

Remove all protective coverings from the shrouds.

Step 7—Attach End Caps and Mast Boot

Tools Used in this Step

#2 Phillips
Screwdriver



Parts Used in this Step

| Item | Part | Description | Qty |
|------|------------|---|-----|
| 1 | 8019194 | BOOT, MAST, DARK | 1 |
| 2 | 8100179 | ASSEMBLY, FRAME END RH, DECAL, BLACK | 2 |
| 3 | 8100180 | ASSEMBLY, FRAME END, LH, DECAL, BLACK | 2 |
| 4 | 102135-001 | SCREW, M5 X 0.8 X 10, PAN HEAD, TYPE 1 CROSS RECESSED, SS | 6 |

- A. Attach one left and one right frame end cover around each frame end and secure in place using six M5 screws (3 per side).

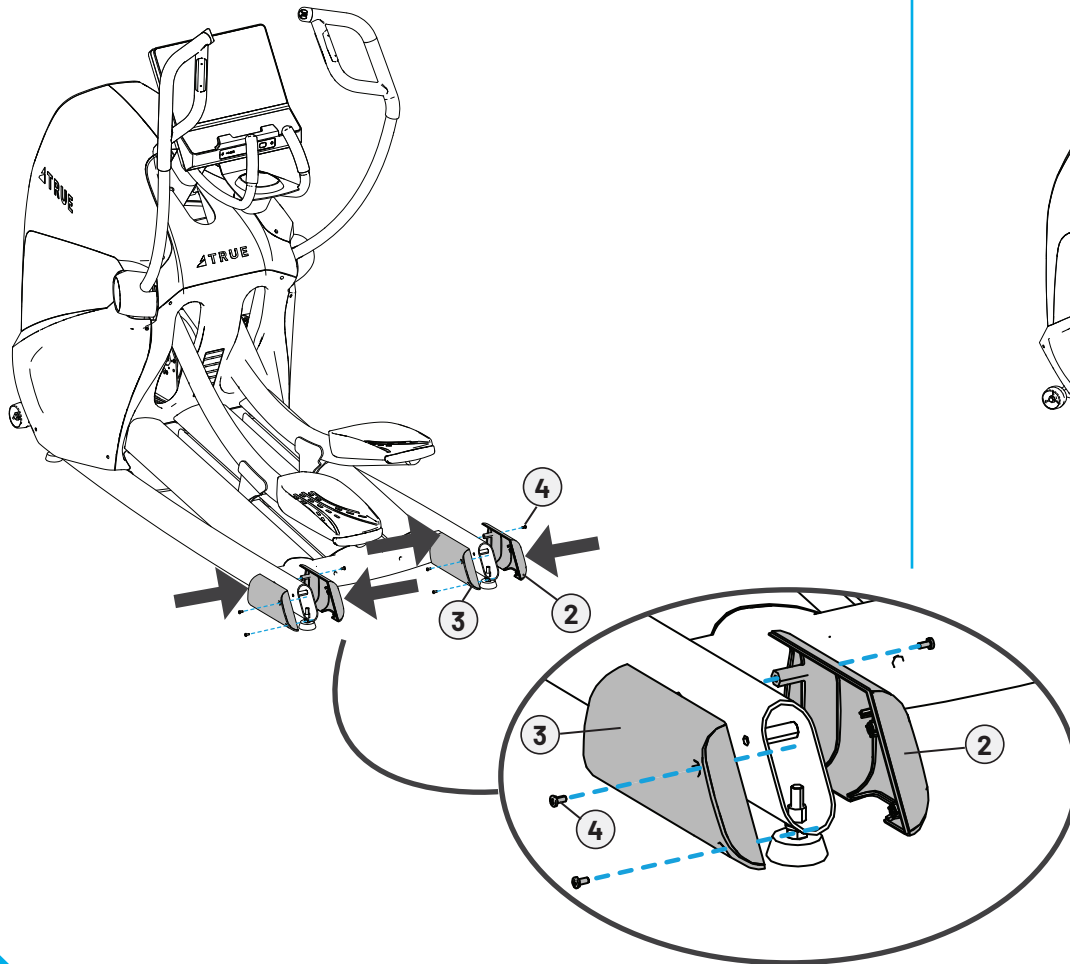

- B. Wrap the mast boot around the base of the mast.

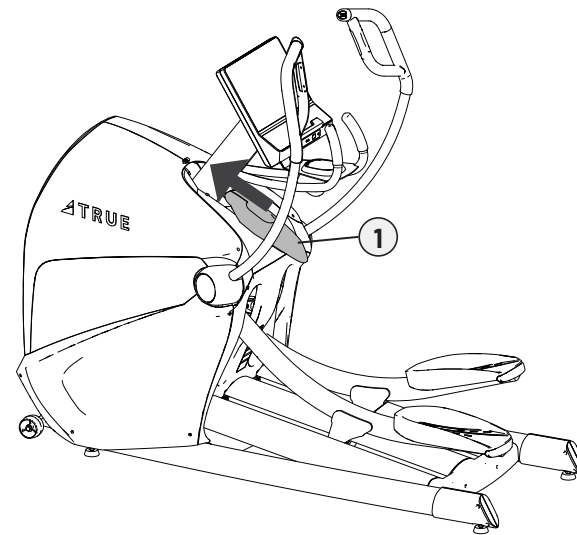

Step 8—Level the Machine

Tools Used in this Step

17mm Wrench



⚠ CAUTION: Prevent potential damage to the machine and injury to the user. This unit is equipped with four leveling feet. Make sure that the machine is level at all times. If the machine is placed on a uneven surface, adjusting the leveling feet can help, but may not completely compensate for extremely uneven surfaces. Equipment that is not level can cause damage to the machine and possible injury to the user. Once the machine has been moved to its designated location:

- A. Using a 17mm wrench, adjust all four leveling feet until they contact the floor.

IMPORTANT! Do not adjust the leveling feet to such a height that they detach or unscrew from the machine.

- B. Verify all four lock nuts are securely tightened and flush against the bottom of the frame.

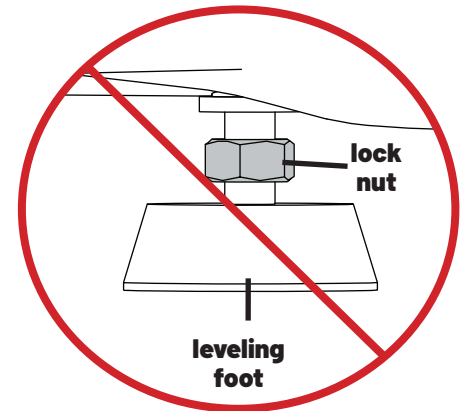
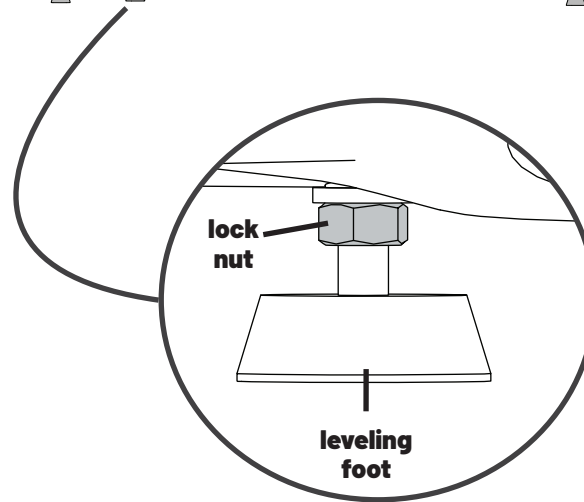
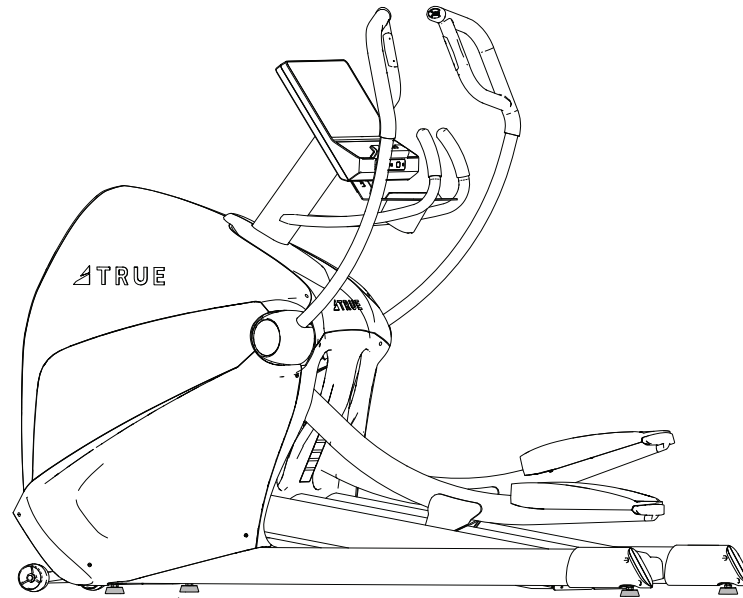

IMPORTANT STEP—DO NOT SKIP!

Step 9—Configure the Console with the Base and Run Calibration*

Please follow the instructions included with your console for important configuration and calibration steps.

Please contact product support right away if you run into issues setting up the machine:
800.883.8783 | service@truefitness.com | Monday–Friday 8:30am–5:00pm (CST)

***NOTE:** All new products require configuration. However, not all new products require calibration. Refer to the table below. If calibration is required, you must calibrate the machine.

| PRODUCT CALIBRATION REQUIREMENTS | | |
|----------------------------------|------------------------------|------------------------------|
| REQUIRES CALIBRATION | DOES NOT REQUIRE CALIBRATION | |
| APEX TREADMILL | APEX ELLIPTICAL | GRAVITY CROSSTRAINER |
| GRAVITY TREADMILL PLUS | APEX CROSSTRAINER | GRAVITY RECUMBENT ELLIPTICAL |
| GRAVITY TREADMILL | APEX RECUMBENT BIKE | LAUNCH ELLIPTICAL |
| LAUNCH TREADMILL DC | APEX UPRIGHT BIKE | LAUNCH RECUMBENT BIKE |
| VAPOR STRYKER | APEX RECUMBENT ELLIPTICAL | LAUNCH UPRIGHT BIKE |
| VAPOR ALPINE RUNNER | GRAVITY ELLIPTICAL | VAPOR PALISADE |
| VAPOR SPECTRUM | GRAVITY RECUMBENT BIKE | VAPOR XT-ONE |
| | GRAVITY UPRIGHT BIKE | VAPOR LATERAL X |

PRODUCT FEATURES

BASE OVERVIEW

- A. Console Assembly**
Controls the machine. Comes equipped with preprogrammed and customizable workouts.
- B. Phone and Water Bottle Holder**
Store water bottle or phone while working out.
- C. Transport Rollers**
Aids in moving the machine.
- D. Power and Cabling Interface**
Power, network, and coaxial ports are only applicable to non-LED consoles.
- E. Leveling Feet**
Adjustable feet to aid in leveling the machine.
- F. Pedals**
Close pedal spacing, 1.8" (4.6cm), to align the body from head to toe and reduce pressure on the lower back.
- G. Converging Multigrip Handlebars with Contact Heartrate Grips**
Patented, one-of-the-kind converging path and multigrip handlebars to better engage the upper body and fit every exerciser comfortably. Check heartrate without wearing a wireless chest strap.
- H. Stationary Handlebars**
Helps to stabilize the upper body during lower body only exercises.



CONSOLE OVERVIEW

UNITE TOUCHSCREENS (16" SHOWN)

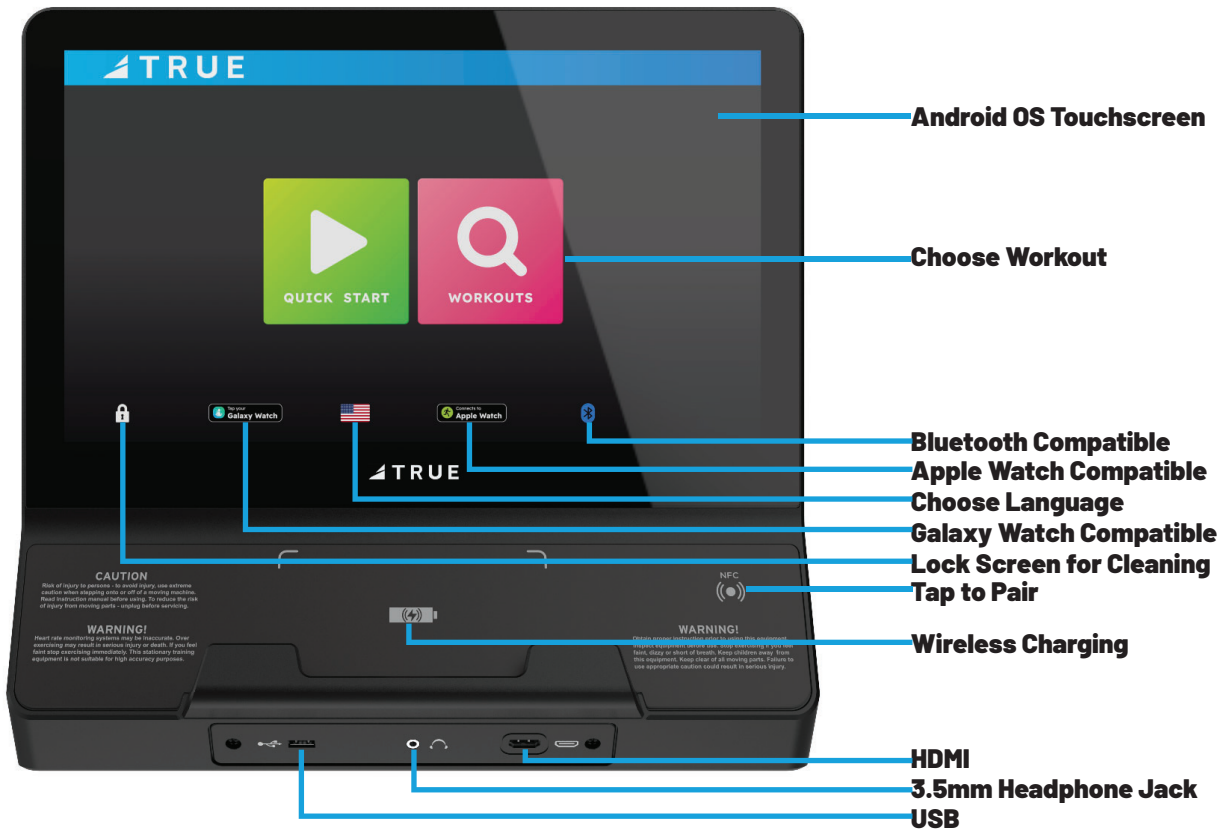

UNITE LED

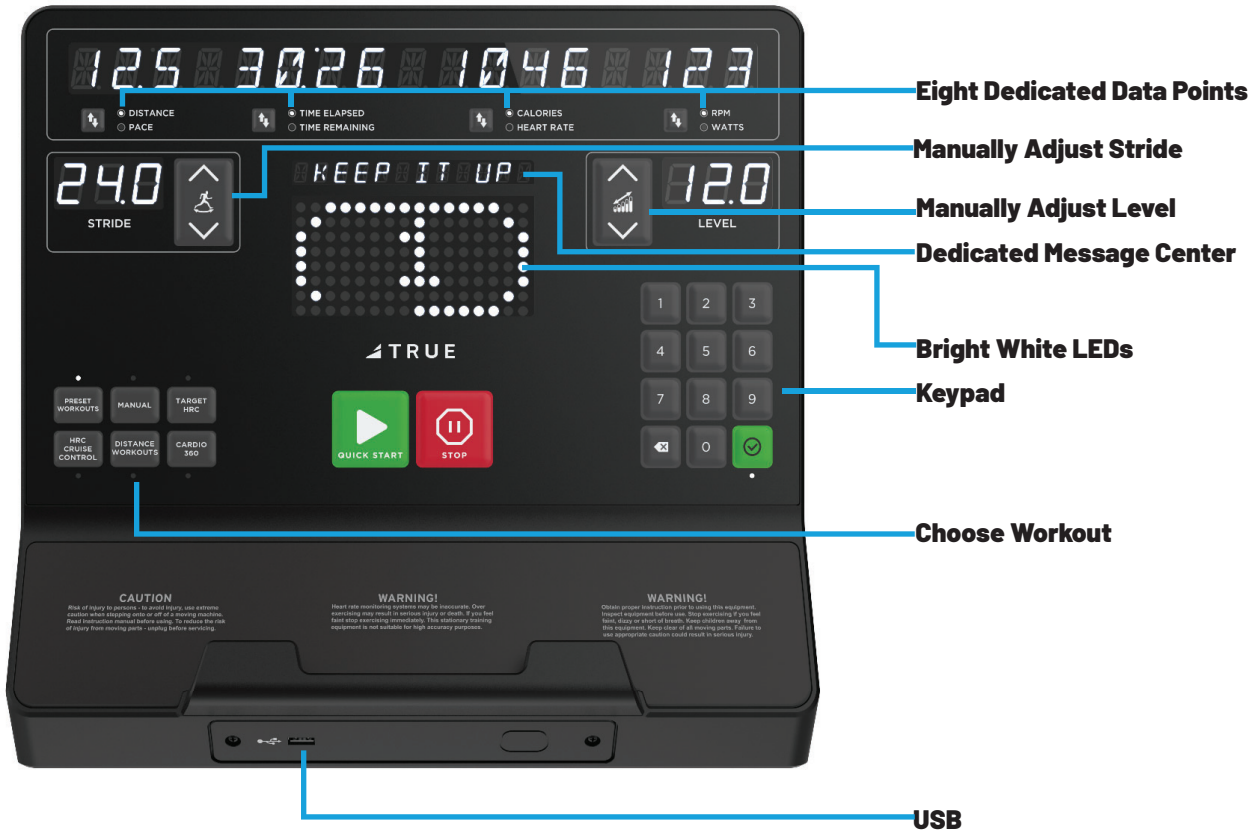

CARE AND MAINTENANCE

It is important to perform the minor maintenance tasks described in this section. Failure to maintain the equipment as described here could void the TRUE Fitness Warranty. To reduce the risk of electrical shock, always unplug the unit from its power source before cleaning or performing any maintenance tasks.

INSPECTION

TRUE is not responsible for performing or scheduling regular maintenance or inspections. Users should inspect the machine daily. Look and listen for slipping belts, loose fasteners, unusual noises, worn or frayed power cords, and any other indications that the equipment may be in need of service. If any of these are noticed, obtain service. Do not attempt to use the machine until proper service has been performed or damaged parts have been replaced.

IMPORTANT!

If you determine that the machine needs service, make sure it cannot be used inadvertently. Turn the unit off, and then unplug the power cord from its power source. Make sure other users know that the machine needs service. To order parts or to contact a TRUE authorized service representative, please visit www.truefitness.com.

CLEANING THE EQUIPMENT

AFTER EACH USE

- Use GymWipes™ Antibacterial wipes or spray a solution of 30 parts water to 1 part mild detergent to dampen a soft cloth and wipe all exposed surfaces.
- Use a LCD/screen cleaner or spray a solution of 1 part 91% isopropyl alcohol and 1 part water to dampen a soft cloth and wipe the surface of the console. This helps remove fingerprints, dust, and dirt.

WEEKLY

- **Vacuum**—Vacuum any dust or dirt that might have accumulated under or around the machine. Clogged air vents can prevent adequate cooling, causing a shortened life.

⚠ CAUTION:

Do not use any acidic cleaners. Doing so will weaken the paint or powder coatings and may void the TRUE Fitness Warranty. Never pour water or spray liquids on any parts of the machine. Allow the machine to dry completely before using. Frequently vacuum the floor underneath the unit to prevent the accumulation of dust and dirt, which can affect the smooth operation.

LEVELING THE MACHINE

⚠ CAUTION:

Prevent potential damage to the machine and injury to the user. This unit is equipped with adjustable leveling feet. Make sure that the machine is level at all times. If the machine is placed on a uneven surface, adjusting the feet can help, but may not completely compensate for extremely uneven surfaces. Machines that are not level can cause possible injuries for the user.

- A. Adjust all four leveling feet until they contact the floor.

IMPORTANT! Do not adjust the leveling feet to such a height that they detach or unscrew from the machine.

- B. Using a 17mm wrench, verify all four lock nuts are securely tightened and flush against the bottom of the frame.

PREVENTATIVE MAINTENANCE

TRUE recommends that quarterly scheduled maintenance be performed by a qualified service technician. Please contact your dealer or visit www.truefitness.com to contact a local TRUE authorized service technician.

IMPORTANT! Use only TRUE Fitness certified service providers. Using non-authorized service providers could void the TRUE Warranty.

| Frequency | Tasks |
|-----------|--|
| Daily | <ul style="list-style-type: none">• Look and listen for slipping belts, loose fasteners, unusual noises, worn or frayed cables, and any other indications that the equipment may be in need of service.• Use GymWipes™ Antibacterial wipes or spray a solution of 30 parts water to 1 part mild detergent to dampen a soft cloth and wipe all exposed surfaces.• Use a LCD/screen cleaner or spray a solution of 1 part 91% isopropyl alcohol and 1 part water to dampen a soft cloth and wipe the surface of the console. This helps remove fingerprints, dust, and dirt. |
| Weekly | <ul style="list-style-type: none">• Vacuum any dust or dirt that might have accumulated under or around the machine. |
| Quarterly | <ul style="list-style-type: none">• Record time, distance, and hours from the console.• Check error log in console.• Remove shroud covers and vacuum any debris out of the speed sensor, control electronics and moving parts.• Move and vacuum underneath the machine.• Inspect all fasteners.• Inspect all electrical connections.• Inspect components for abnormal or premature wear. |

LONG TERM STORAGE

When the machine is not in use for any length of time, turn it off. Make sure that the power cord is unplugged from the power source and is positioned so that it will not become damaged or interfere with people or other equipment.

ADDITIONAL INFORMATION

TROUBLESHOOTING

This troubleshooting information is intended to assist in diagnostics only and is not all inclusive. Technical specifications, error codes, and programming are subject to change without notice. TRUE accepts no liability for any damage or loss suffered by persons whom rely wholly or in part on any description or statement contained within this manual. Please visit www.truefitness.com to obtain the most recent version of all manuals and contact TRUE product support (800-883-8783) for assistance with troubleshooting and diagnostics.

| Malfunction | Possible Cause | Corrective Action |
|--------------------------------|---|---|
| No power | Damaged power cord | Replace power cord |
| | Power cord not fully seated in socket | Inspect power connection at the unit and outlet |
| | No power at outlet | Using a voltmeter verify power at outlet |
| | Motor control board damaged | Contact TRUE Product Support |
| | Battery disconnected | Verify battery connection Connect battery if disconnected |
| | Low battery voltage | Verify battery voltage is 24V |
| Unit resets or pauses randomly | Damaged power cord | Replace power cord |
| | Power cord not fully seated in socket | Inspect power connection at the unit and outlet |
| | Insufficient power | Verify output voltage from 20A outlet with a voltmeter Verify battery voltage is 24V |
| | Error code is displayed on console | Contact TRUE Product Support |
| | Pinched or loose main communication cable | |
| No TV displayed or low quality | Low or bad video signal | Contact video provider |
| | | NTCS dBmV0 through 15.6 ATCS/QAM dBmV-10 through 15.5 |
| | Loose F type connector (coaxial cable) | Inspect all connections |
| | Encrypted video | Obtain set top box from video provider |
| | Channels or format type not correct | Verify video type with provider; analog (NTCS), digital air (ATCS), digital cable (QAM) |
| | | Rescan TV channels |
| Tuner Invalid | Contact TRUE Product Support | |

| Malfunction | Possible Cause | Corrective Action |
|--|--|--|
| Heart rate is displaying erratically or not displaying | Transmitter belt contacts are not making good contact with the skin | Re-adjust the transmitter belt so that it is in full contact with the skin |
| | Contacts on the transmitter belt are not moist | Moisten the contacts on the transmitter belt |
| | Transmitter belt is not within 3 feet (1 meter) of the heart rate receiver | Adjust your position on the belt so that you are within 3 feet (1 meter) of the console |
| | The battery inside the transmitter belt is depleted | Replace the transmitter belt with a compatible transmitter belt |
| | Another user wearing a compatible transmitter strap is within 3 foot (1 meter) of the unit | Move the units so that there is more space in-between units |
| | Environmental interference from high voltage power lines | Move the unit to another position within the room or move the cause of the interference until heart rate reading are stable. If the probable source of interference is plugged into the same outlet move the suspect source to another outlet. |
| | Environmental interference from computers | |
| | Environmental interference from motor driven appliances | |
| | Environmental interference from cell or cordless phone | |
| | Environmental interference from Wi-Fi router | |
| Contact Heart Rate not displaying | Machine needs to be restarted | Power cycle |
| | Cables are pinched or damaged | Contact TRUE product support |
| | Nucleus board may be damaged | Contact TRUE product support |
| | Heart Rate Grips may be damaged | Contact TRUE product support |

WARRANTY INFORMATION

COMMERCIAL WARRANTY

| CARDIO | | | | |
|---------------|-------------|--------------|----------|----------------|
| WARRANTY ITEM | VAPOR, APEX | GRAVITY PLUS | GRAVITY | ADX, RO, SURGE |
| Frame* | 7 Years | 7 Years | 7 Years | 5 Years |
| Parts | 3 Years | 3 Years | 3 Years | 3 Years |
| Consoles | 3 Years | 3 Years | 3 Years | 2 Years |
| Labor** | 2 Years | 2 Years | 1 Year | 1 Year |
| Wear Items*** | 180 Days | 180 Days | 180 Days | 90 Days |

| FLEXIBILITY | |
|--------------------|---------|
| WARRANTY ITEM | STRETCH |
| Parts | 1 Year |
| Wear Items*** | 90 Days |

| STRENGTH | |
|----------------------------|--|
| WARRANTY ITEM | PALLADIUM, FUSE XL, FORCE, FITNESS LINE, ATLAS, XFT, XFW, MP, SM, FT, FS |
| Frame* | 10 Years |
| Parts | 5 Years |
| Cables and Linear Bearings | 1 Year |
| Labor** | 1 Year |
| Wear Items*** | 90 Days |

Warranty does not cover damage or equipment failure resulting from or caused by improper assembly/installation, accident, misuse, abuse, unauthorized modification, or failure to provide reasonable and necessary maintenance.

*Frame is the serialized base of the unit and does not include paint or coatings.

**Labor is available for equipment located within United States and Canada.

***Wear Items include: batteries, covers, caps, badges, paint, pedal straps, toe clips, elliptical pedal inserts, foot pads, Coax/TV, HDMI, USB, mirroring or Ethernet connections, and safety key.

See Warranty Details for terms, conditions, and complete coverage details.

LIMITED-USE COMMERCIAL WARRANTY*

| CARDIO | | | | |
|----------------------|--------------------|---------------------|----------------|---------------|
| WARRANTY ITEM | VAPOR, APEX | GRAVITY PLUS | GRAVITY | LAUNCH |
| Frame*** | 7 Years | 7 Years | 7 Years | 7 Years |
| Parts | 5 Years | 5 Years | 5 Years | 3 Years |
| Consoles | 3 Years | 3 Years | 3 Years | 3 Years |
| Labor**** | 3 Years | 3 Years | 2 Years | 1 Year |
| Wear Items***** | 180 Days | 180 Days | 180 Days | 180 Days |

IN-HOME USE WARRANTY**

| CARDIO | | | | |
|----------------------|--------------------|---------------------|----------------|---------------|
| WARRANTY ITEM | VAPOR, APEX | GRAVITY PLUS | GRAVITY | LAUNCH |
| Frame*** | 12 Years | 12 Years | 12 Years | 7 Years |
| Parts | 10 Years | 7 Years | 7 Years | 5 Years |
| Consoles | 3 Years | 3 Years | 3 Years | 3 Years |
| Labor**** | 2 Years | 1 Year | 1 Year | 1 Year |
| Wear Items***** | 180 Days | 180 Days | 180 Days | 180 Days |

TRUE Fitness may offer alternative warranties to purchasers of commercial equipment for limited-use commercial* or in-home use.** This policy ensures that customers who use commercial equipment for limited-use commercial or in-home use may receive alternative warranty coverage, provided they meet the specified requirements. It's important to note that the specific terms and conditions of the alternative warranty, as well as the eligibility criteria, may vary depending on the product and TRUE's policies at the time of purchase. Customers should review the warranty terms and contact TRUE for precise details.

*To be eligible for the alternative limited-use commercial warranty, equipment use cannot exceed 6-hours use a day or be for use in a membership, dues paying, or institutional facility.

**To be eligible for the alternative in-home use warranty, equipment must be registered to a home address and cannot be used outside of the purchaser of the equipment and their immediate family.

Customers must provide TRUE with the following within 30 days of installation of the commercial-rated equipment:

- Purchase agreement.
- Proof of professional delivery and installation.
- TRUE will register the alternative warranty for the purchaser and implement it within 90 days of receiving the required documentation if such an alternative warranty is available for the specific product.

Warranty does not cover damage or equipment failure resulting from or caused by improper assembly/installation, accident, misuse, abuse, unauthorized modification, or failure to provide reasonable and necessary maintenance.

***Frame is the serialized base of the unit and does not include paint or coatings.

****Labor is available for equipment located within United States and Canada.

*****Wear Items include: batteries, covers, caps, badges, paint, pedal straps, toe clips, elliptical pedal inserts, foot pads, Coax/TV, HDMI, USB, mirroring or Ethernet connections, and safety key.

See Warranty Details for terms, conditions, and complete coverage details.

WARRANTY DETAILS

All TRUE Fitness products are distributed by TRUE and are warranted to the original registered product purchaser and the parts of the TRUE product (the "Product") listed below, under normal use and service, shall be free of manufacturing defects in workmanship and materials only for the specified period of time.

NOTE:

- Standard shipping is included with warranty part replacement.
- Shipping for warranty frame or replacement is included for the period of three years from the original date of purchase.

All Warranty Items are "LIMITED"

- This limited warranty does not cover damage or equipment failure resulting from or caused by improper assembly/installation, failure to follow instructions and warnings in owner's manual, accident, misuse, abuse, unauthorized modification, failure to provide reasonable and necessary maintenance, software version upgrades, compatibility with third party/aftermarket hardware, software, applications, or websites.
- TRUE's liability shall under no circumstances exceed the actual amount paid by you for the product, nor shall TRUE under any circumstances be liable for any consequential, incidental, special or punitive damages or losses, whether direct or indirect.
- Some states or countries do not allow the exclusion or limitation of incidental or consequential damages, so the above limitation or exclusion may not apply to you.
- TRUE will neither assume nor authorize any person to assure for us any other obligation or liability concerning the sale of this Product. Under no circumstances shall TRUE be liable under this warranty, or otherwise, of any damage to any person or property, including any lost profits or lost savings, for any special, indirect, secondary, incidental, or consequential damages arising out of the use of or inability to use this Product.
- This limited warranty, which is given expressly and in lieu of all other express warranties, constitutes the only warranty made by TRUE.
- The remedies described herein are your sole and exclusive remedies and TRUE's entire liability for any breach of this limited warranty.
- No one is authorized to change, modify, or extend the terms of this limited warranty.
- This limited warranty is in lieu of all other warranties of any kind either expressed or including but not limited to implied warranties of merchant.
- This limited warranty applies to the product only while the product remains in the possession of the original purchaser and is not transferable.
- This limited warranty becomes VALID ONLY if the Product is initially assembled/installed by a TRUE authorized dealer/technician (if anyone other than a TRUE authorized dealer/technician initially assembles and installs the Product, this limited warranty will be void unless the written authorization of TRUE is first obtained).
- This limited warranty can be processed only if the warranty registration form is completed on-line; or if the form provided with equipment is filled in, signed by the original purchaser, and mailed to TRUE within 30 days of purchaser's receipt of this Product.
- All serial numbers must be intact on the Product for this limited warranty to be valid.
- Installation or download of any 3rd party or after-market products will result in voided warranty. This includes, but is not limited to, electrical and mechanical parts, software, or applications.
- TRUE will ship to an authorized service provider any new or rebuilt replacement part or component, or at our option, replace or refund the Product.
- Replacement parts are warranted for the remaining portion of the original warranty period.
- Proof/receipts of necessary maintenance may be required within 30 days of requested warranty part or service.
- This limited warranty does not apply to the performance of the heart rate accuracy will not be warranted as performance varies, based on user's physiology, age, method of use, and other external factors.

WARRANTY REGISTRATION

Thank you for purchasing a TRUE product!

For warranty terms and conditions, see the complete owner’s manual and assembly guide located at truefitness.com.

To validate your product warranty, you must register your product within 30 days of purchaser’s receipt of this product.

To register your product:

- Go online to: <https://truefitness.com/services-support/warranty-registration/>
OR
- Complete the information below and mail to:
TRUE Product Support
865 Hoff Road
St. Louis, MO 63366

PLEASE RETAIN THIS PORTION FOR YOUR RECORDS
BASE SERIAL NUMBER:
CONSOLE SERIAL NUMBER:



WARRANTY REGISTRATION

Base Serial Number

Console Serial Number

Purchase Date

Company (if applicable)

Customer Name (First and Last)

Email Address

Phone Number

Street Address

City

State

Postal Code

Country



CONTACT US
service@truefitness.com
800.883.8783

865 Hoff Road
St. Louis, MO 63366

[TRUEFITNESS.COM](https://www.truefitness.com)



MAN-XC1-XA-35 Owner's Manual and Assembly Guide REV02

© 2024 TRUE Fitness All Rights Reserved.