

 **TRUE FITNESS**



VAPOR PALISADE CLIMBER

OWNER'S MANUAL AND ASSEMBLY GUIDE

IMPORTANT—PLEASE READ

All products shown are prototype. Actual product delivered may vary. Product specifications, features, and software are subject to change without notice.

For the most up-to-date version of this manual, please see our website: <https://truefitness.com/services-support/user-manuals/>

CONTACTING OUR SUPPORT TEAM

To contact TRUE for any of your pre or post installation questions, please call our toll-free numbers Monday - Friday 8:30am - 5:00pm (CST):

- Commercial Direct Customers and Corporate Accounts | 800.868.8783
- Retail Customers and Distributors | 800.883.8783

Or email us:

- Commercial Direct Customers and Corporate Accounts | service.direct@truefitness.com
- Retail Customers and Distributors | service@truefitness.com
- Service International | int.service@truefitness.com

When contacting TRUE, please have the following information ready:

- Serial Number of Unit
- Contact Information—Full Name, Email, and Phone Number
- Address of Facility or Residence
- Detailed Description Regarding Symptom of the Unit (along with pictures or video if applicable)

NOTE: Authorized service providers, dealers, and distributors may also use TRUE's online resource | portal.truefitness.com.

CONTACTING OUR SALES TEAM

Interested in owning more TRUE products? Please contact us with any product inquires so that we may direct you to the appropriate sales representative to help answer your questions.

- Phone | 800.426.6570
- Email | sales@truefitness.com
- Hours | Monday - Friday 8:30am - 5:00pm (CST)

REPORTING FREIGHT CLAIMS OR PARTS DAMAGE

Unfortunately, sometimes materials can be damaged during shipment. If materials are damaged during shipment, please follow the guidelines below to determine the appropriate process for you to follow.

Severe Damage—Obvious damage to external packaging and internal product.

Please refuse the shipment and it will be returned to TRUE by the carrier. Contact TRUE product support by calling 800.883.8783 or sales support by calling 800.426.6570 Monday–Friday during normal business hours to notify us that the shipment has been refused. Once we have received the damaged shipment, a replacement shipment will be sent to you. If the shipment comes in multiple boxes, only refuse boxes with damage.

Slight Damage—Minimal damage to external packaging with unknown internal damage to product.

If the shipment has minimal damages and you are not sure if the actual product is damaged, you must sign the bill of lading as damaged when accepting the shipment. Once you have opened the box and you have determined something is indeed damaged, please gather the serial number, model number, description of damage, and photos of damage. Please make sure the photos include the damaged product as well as the damaged box the product arrived in. Contact TRUE product support (service@truefitness.com | 800.883.8783) or TRUE sales support (sales@truefitness.com | 800.426.6570) Monday–Friday during normal business hours.

Concealed Damage—No damage to external packaging but internal damage to product.

You may receive a shipment that looks intact and discover once the box has been opened that there are hidden damages. Please notify the carrier immediately. TRUE will not be able to file a claim if the carrier is not notified in a timely manner. Once you have called the carrier you will need to gather the serial number, model number, description of damage, and photos of damage. Contact TRUE product support (service@truefitness.com | 800.883.8783) or TRUE sales support (sales@truefitness.com | 800.426.6570) Monday–Friday during normal business hours.

TABLE OF CONTENTS

SAFETY INSTRUCTIONS

IMPORTANT SAFETY INSTRUCTIONS—SAVE THESE INSTRUCTIONS.....	5
POWER REQUIREMENTS.....	7
SPACE REQUIREMENTS.....	8
SPECIFICATIONS.....	8
WARNING DECALS.....	9
COMPLIANCES.....	9
PROPER CLIMBER ENTRY AND EXIT SAFETY.....	10

ASSEMBLY INSTRUCTIONS

PREASSEMBLY CHECKLIST.....	11
ASSEMBLY STEPS.....	15

PRODUCT FEATURES

BASE OVERVIEW.....	27
CONSOLE OVERVIEW.....	28

CARE AND MAINTENANCE

INSPECTION.....	30
CLEANING THE EQUIPMENT.....	30
LEVELING THE MACHINE.....	30
PREVENTATIVE MAINTENANCE.....	31
LONG TERM STORAGE.....	31

ADDITIONAL INFORMATION

TROUBLESHOOTING.....	32
----------------------	----

WARRANTY INFORMATION

COMMERCIAL WARRANTY	34
LIMITED-USE COMMERCIAL WARRANTY.....	35
IN-HOME USE WARRANTY.....	35
WARRANTY DETAILS.....	36
WARRANTY REGISTRATION.....	37

SAFETY INSTRUCTIONS

IMPORTANT SAFETY INSTRUCTIONS—SAVE THESE INSTRUCTIONS

This equipment is intended for a commercial or institutional setting. This owner's manual should be accessible to all personal trainers, faculty, and members.

- Read and understand all instructions and warnings prior to use.
- Obtain a medical exam before beginning any exercise program. If at any time during exercise you feel faint, dizzy, or experience pain, stop and consult your physician.
- Obtain proper instruction prior to use.
- This unit is intended for commercial use only.
- Inspect the unit for incorrect, worn, or loose components and do not use until corrected, replaced, or tightened prior to use.
- Do not wear loose or dangling clothing while using the unit.
- Care should be used when mounting or dismounting the unit.
- Read, understand, and test the emergency stop procedures before use.
- Disconnect all power before servicing the unit.
- Do not exceed maximum user weight of 400 lbs / 181 kg.
- Keep the top side of the moving surface clean and dry.
- Keep children and animals away.
- Use caution when moving and assembling unit.
- All exercise equipment is potentially hazardous. If attention is not paid to the conditions of equipment usage, death, or serious injury could occur.

⚠ WARNING: To reduce the risk of burns, fire, and electric shock or injury to persons, follow these instructions:

- Heart rate monitoring systems may be inaccurate. Over-exercising may result in serious injury or death. If you feel faint, dizzy, or experience pain, stop exercising immediately.
- Health related injuries may result from incorrect or excessive use of exercise equipment.
- TRUE STRONGLY recommends seeing a physician for a complete medical exam before undertaking an exercise program, particularly if the user has a family history of high blood pressure or heart disease, is over the age of 45, smokes, has high cholesterol, is obese or has not exercised regularly in the past year. Additionally, TRUE recommends consulting a fitness professional on the correct use of this product.
- Equipment should be immediately taken out of use if it fails to work properly or when a warning is presented electronically.
- When using this exercise machine, basic precautions should always be followed.
- Use this equipment only for its intended use as described in this manual.
- Do not move the equipment by lifting the console. Do not use the console as a handlebar during a workout.
- This product can expose you to chemicals including Toluene and Acrylamide which are known to the State of California to cause Cancer and birth defects or other reproductive harm. For more information, go to www.P65Warnings.ca.gov.
- Keep equipment stable on flat ground.
- Risk of personal injury—crushing hazard when equipment is in operation. Keep feet, hands, and fingers away from moving parts.
- Replace warning labels that may be worn, damaged, or missing.
- Replace any non-working or damaged components, remove the unit from service until repair is performed.
- Do not operate the equipment while being covered with a blanket, pillow, plastic, or anything that insulates or stops airflow. Keep air openings free of lint, hair or any obstructing material.
- Any changes or modifications to this equipment could void the product warranty.
- Do not use this product in areas where aerosol spray products are being used or where oxygen is being administered. Such substances create the danger of combustion and explosion.
- Do not use this product outdoors, near water, while wet, or in areas of high humidity including extreme temperature changes.
- Close supervision is necessary when used near children under the age of 15, or disabled persons.

- Wear shoes with rubber or high traction soles. Do not use shoes with heels, leather soles, cleats or spikes. Make sure no stones are embedded in the soles. Do not use this product in bare feet. Keep all loose clothing, shoelaces and towels away from moving parts.
- Avoid the possibility of bystanders being struck or caught between moving parts by making sure that they are out of reach of the equipment while it is in motion.
- Do not use typing or web surfing features at excessive speeds. Always stabilize yourself when using typing or web surfing features. (Varies by console option.)
- Never place liquids of any type directly on the unit except in the accessory tray or bottle holders. Containers with lids are recommended.
- Always follow the console instructions for proper operation.
- Allow only one person at a time on the equipment while it's operating.
- Use the side handrails whenever additional stability is required. In case of emergency, such as tripping, the side handrails should be grabbed, and the user should place his/her feet on the side platforms. The front handlebars should be used to grasp the heart rate sensors or to rest the hand on while operating the activity zone keys, but not for stability, emergency, or continuous use.
- To avoid injury, stand on the side steps before starting the equipment.
- Avoid exiting the equipment while the steps are in motion.
- Never walk backwards on the equipment.
- When mounting the equipment, ensure the steps are not in motion and then proceed with one step at a time to maintain balance using the handrails as needed.
- While the equipment is in use, proceed at a speed that the user can safely maintain with the ability to immediately engage the safety key to stop the machine if necessary.
- Do not allow animals on or near the equipment while in operation.
- Do not reach into or underneath the unit, or tip it on its side during operation.
- To avoid serious injury, never touch the steps while the machine is in use.

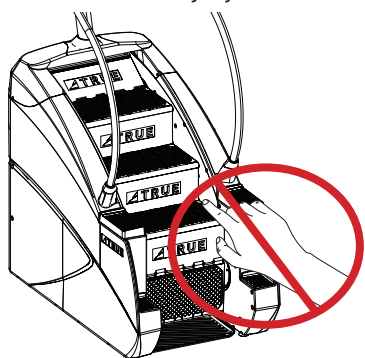

- Do not use if you have a cold or fever.
- This equipment is not intended for use by persons with reduced physical, sensory, or mental capabilities, or lack of experience and knowledge, unless they are supervised or have been given instruction concerning use of the equipment by a person responsible for their safety.
- Children shall not play with the appliance.
- Cleaning and user maintenance shall not be made by children without supervision.
- Do not use attachments not recommended by the manufacturer.
- Allow only trained personnel to service this equipment.
- It is the sole responsibility of the owner/operator to ensure regular and scheduled maintenance is performed.

⚠ DANGER:

- To reduce the risk of electric shock, always unplug this product when not in use, before cleaning, or attempting any maintenance activity. Do not handle the plug with wet hands.
- Use a TRUE AC power cord only.
- Position this product so the power cord plug is accessible to the user.
- Keep the power cord away from heated surfaces. Do not pull the equipment by the power cord or use the cord as a handle. Do not run the power cord along the side or under the equipment.
- If the electrical supply cord is damaged it must be replaced by the manufacturer, an authorized service agent, or a similarly qualified person to avoid a hazard.
- This product must be connected to a properly grounded electrical outlet.
- Never insert objects into any openings in this product. If an object should drop inside, turn off the power, unplug the power cord from the outlet and carefully retrieve it. If the item cannot be reached, contact TRUE product support.
- To avoid serious injury, remove and store the power cord when the machine is not in use.
- This appliance should never be left unattended when plugged in.
- Do not use any type of extension cord with this product.
- Never operate a TRUE product if it has a damaged power cord or electrical plug, or if it has been dropped, damaged, or even partially immersed in water.

POWER REQUIREMENTS

Read and understand all instructions before plugging any TRUE power cord into an electrical outlet.

DEDICATED LINE

This product does not require a dedicated line.

GROUNDING INSTRUCTIONS

This product must be grounded. If the product malfunctions or breakdowns, grounding provides a path of least resistance for electric current to reduce the risk of electric shock. This product is equipped with a cord having an equipment grounding conductor and a grounding plug. The plug must be plugged into an appropriate outlet that is properly installed and grounded in accordance with all local codes and ordinances.

▲ DANGER:

- Improper connection of the equipment grounding conductor can result in risk of electrical shock.
- Check with a qualified electrician or service provider if you are in doubt as to whether the equipment is properly grounded or installed on a dedicated line.
- Seek a qualified electrician to perform any modifications to the cord or plug. TRUE is not responsible for injuries or damages as a result of cord or plug modification.

- To reduce the risk of burns, fire, electric shock, or injury, it is imperative to connect each product to a properly grounded 110V or 220V electrical outlet. The voltage required for your unit is located on the serial number decal (usually on the front of the unit). Depending on where you live voltage requirements differ.
- Some TRUE products require a circuit rated 110V, 60 Hz, and 20 amps. In the United States, most residential homes have circuits rated 110V, 60 Hz, and 15 amps. If your unit requires a 20 amp outlet, contact an electrician to install a dedicated 20 amp circuit prior to use.
- **110 Volt**—This model is for use on a nominal 110V circuit and has a grounding plug that looks like the plug illustrated in figure A. Make sure the product is connected to an outlet having the same configuration as the plug. No adapter should be used with this product.
- **220 Volt**—This model is for use on a circuit having a nominal rating no less than 208V and more than 240V and is factory equipped with a specific electric cord and has a grounding plug that looks like the plug illustrated in figure B. Make sure that the product is connected to an outlet having the same configuration as the plug in figure B. No adapter should be used with this product. If the product must be reconnected for use on a different type of electric circuit, the reconnection should be made by qualified service personnel.

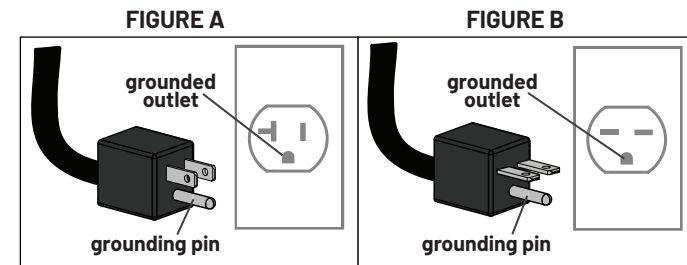

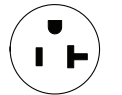
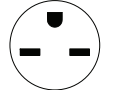
Power Information						
Model	Line Voltage (V)	Frequency (Hz)	Rated Current (Amps)	Number of Units per Circuit	Plug/Outlet*	Max Power Dissipation (Watt)
VC1-0A-35	110	50/60Hz	20	Up to 3 climbers per circuit—DO NOT exceed	NEMA 5-20 	550 watts per machine
	220	50/60Hz	8	Up to 3 climbers per circuit—DO NOT exceed	NEMA 6-15* 	550 watts per machine

*The plug configuration for the power adapter may vary by country.

SPACE REQUIREMENTS

TRUE recommends a minimum of:

- 12" (30.5cm) on each side and the front of the equipment
- 36" (91.4cm) safety zone at the rear of the equipment
- 10 feet (3.1 meters) for a ceiling height

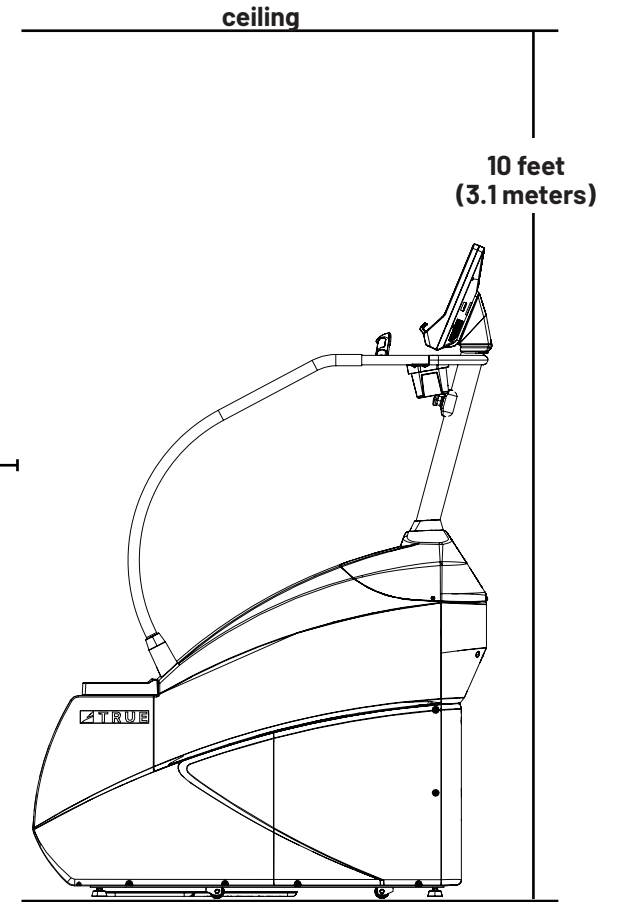
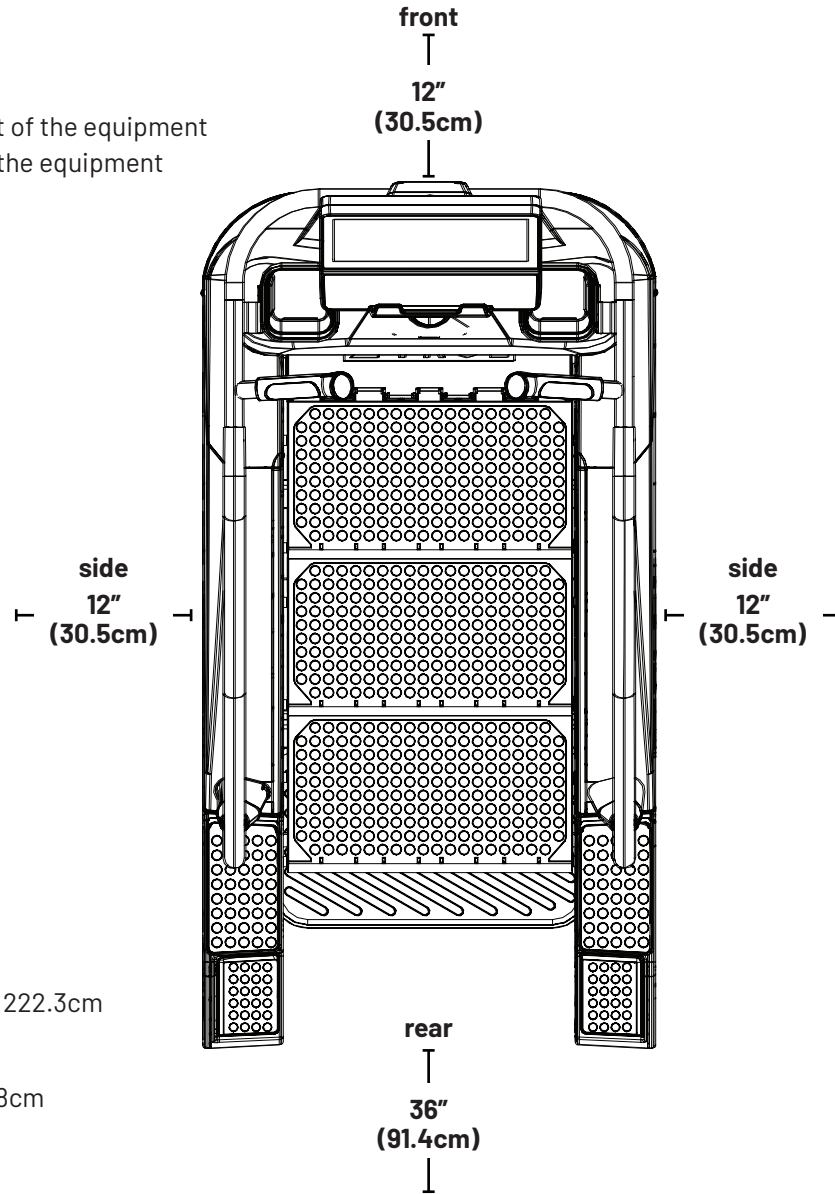

SPECIFICATIONS

- **DIMENSIONS (L X W X H)**
60.4" x 31.5" x 87.5" / 153.4cm x 80cm x 222.3cm
- **STEP DIMENSIONS (L X W X H)**
8" x 11.2" x 20" / 20.3cm x 28.4cm x 50.8cm
- **STEP-UP HEIGHT**
13.3" / 33.7cm
- **MAXIMUM USER WEIGHT**
400 lbs / 181.4 kg

WARNING DECALS

⚠ WARNING: Replace warning labels that may be worn, damaged, or missing.

To replace any worn or missing decals contact TRUE product support (service@truefitness.com | 800.883.8783).

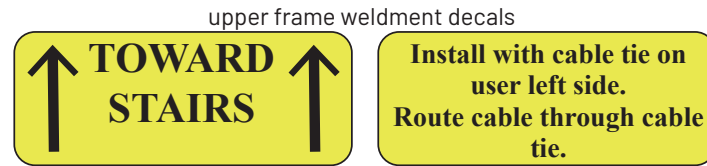
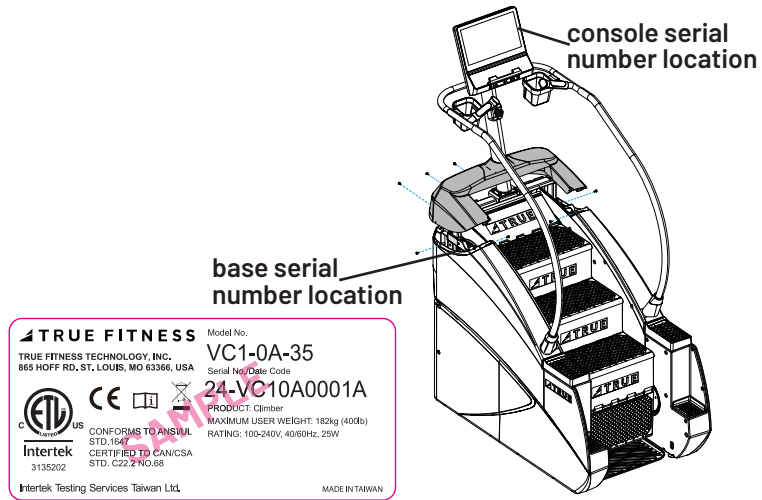

COMPLIANCES

This equipment complies with all applicable codes and regulations. For a complete list of compliances, please visit www.truefitness.com.

PROPER CLIMBER ENTRY AND EXIT SAFETY

To Enter:

- Step up onto the lower, rear steps one at a time while gripping both handrails for support.
- Step up onto the upper, rear steps one at a time while gripping both handrails for support.
- Position both feet on the lowest step closest to the upper, rear steps while gripping the handrails.



To Exit:

- At the conclusion of the workout after the steps have ceased all movement, position both feet on the upper, rear steps one at a time while gripping the handrails.
- Step down onto the lower, rear steps one at a time while maintaining a grip with both hands on the handrails.
- Step down onto the floor one foot at a time while maintaining a grip with both hands on the handrails.



ASSEMBLY INSTRUCTIONS

 **NOTE:** Supplemental video available @TRUEFitnessservicevids: <https://www.youtube.com/playlist?list=PLr3lgy32Uruq4XAsK00Z44g7bL-ROZ-qU>

PREASSEMBLY CHECKLIST

BASIC GUIDELINES FOR SETTING UP THE EQUIPMENT

After removing the equipment from the packaging, place the equipment on a clean, level surface. Make sure the electrical cord easily reaches a grounded three-pronged outlet.

⚠ DANGER: Do not use an extension cord or ungrounded outlet. The ground helps prevent electrical damage to your equipment and enhances your safety by helping to prevent shock. Check with a qualified electrician or serviceman if you are in doubt as to whether the equipment is properly grounded. Do not modify the plug provided with the unit if it will not fit the outlet. Have a proper outlet installed by a qualified electrician.



⚠ CAUTION:





Use caution when assembling the equipment.
Unpacking and assembling of this product is a two person task.

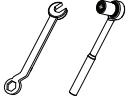

Use caution when unpacking this product. Avoid damage to the product.
DO NOT use a box cutter. DO NOT slice into the packaging.

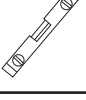
TOOLS NEEDED FOR ASSEMBLY	
5mm and 6mm Allen Wrench	
17mm Wrench and 17mm Socket Wrench	
#2 Phillips Screwdriver	

TOOLS NEEDED FOR ASSEMBLY	
Wire Cutters	
Level (recommended)	
Lifting Straps (recommended)	

VERIFY BOX CONTENTS

IMPORTANT! Please verify box contents. If you have questions, or if there are any missing parts, contact product support (service@truefitness.com | 800.883.8783).

TO UNBOX THE MACHINE

1. After opening the product box, remove all smaller parts, boxes, and plastic wrapping.
2. On each side of the machine, remove the protective wood from the top of the base and from each handrail.
3. From each side of the machine, remove the three zip ties securing the product to the shipping pallet.
4. Carefully tilt the product base upward to position the lifting straps underneath. Using two people, carefully lift the product off the shipping pallet and place on the ground.
5. If the product is near its final resting position, carefully tilt the product on each side and adjust the leveling feet until the product base is parallel with the ground. DO NOT tilt the product base too far on either side to avoid damaging the plastics.
6. If the product is far from its final resting position, use the moving wheels to move the product into place and then adjust the four leveling feet to verify the machine is level with the ground.

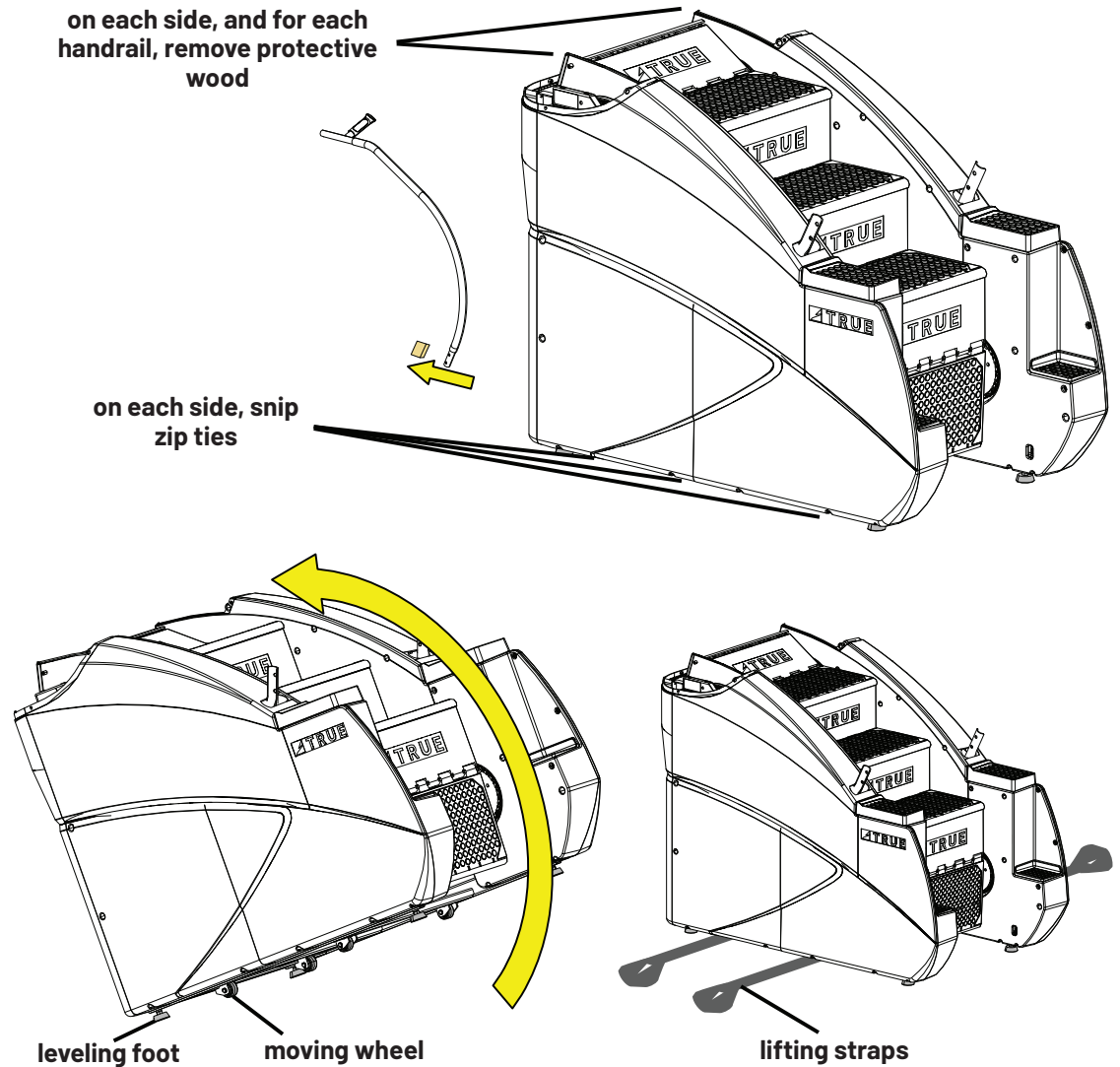

BOX CONTENTS

ITEM	PART	DESCRIPTION	QTY
1	VC90003-35	WELDMENT, UPPER FRAME	1
2	VC90009-35	WELDMENT, CUP HOLDER RING, LH	1
3	VC90010-35	WELDMENT, CUP HOLDER RING, RH	1
4	VC90019	BRACKET, HAND RAIL CLAMP	2
5*	VC90030	INSERT, CUP HOLDER PAD	8
6	VC90080	CABLE, VC900 POWER	1
7	VC90090	SHROUD, TOP, WITH DECAL	1
8	VC90103	SHROUD, INNER GUARD	1
9	VC90111	PLASTIC, CUP HOLDER	2
10*	VC90112	COVER, MAST BASE	1
11	VC90117	COVER, HANDRAIL BASE, LH	1
12	VC90118	COVER, HANDRAIL BASE, RH	1
13**	VC90148	PHMS, M5-0.8 X 12MM, ZP	14
14**	VC90151	WASHER, FLAT, M8 X 18 OD X 1.5, BLK, ZP	4
15**	VC90167	BHCS, M8-1.25 X 12MM, SS	4
16**	VC90168	HHS, M10-1.50 X 50MM, NYLOC, BLK ZP	4
17**	VC90169	HEX NUT M10 X 1.5 X 8 BZ	4
18**	VC90175	PHMS, M5-0.8 X 6MM, ZP	1
19**	VC90176	SHCS, M8-1.25 X 20MM, BLK ZP	4
20	VC90271	ASSEMBLY, HARDWARE PACK	1
21**	VC90205	SHCS, M8-1.25 X 20MM, SS	4
22**	VC90206	WASHER, FLAT, M8 X 18 OD X 1.5, SS	4
23	VC90250-35	VC900 BASE ASSEMBLY	1
24	VC90251-35	SUBASSEMBLY, CONSOLE MAST, INTERNATIONAL	1
25	VC90254-35	ASSEMBLY, LEFT HANDRAIL & HR GRIP, FULL DIPPED	1
26	VC90255-35	ASSEMBLY, RIGHT HANDRAIL & HR GRIP, FULL DIPPED	1
27	VC90110	COVER, CONSOLE REAR	1
28	VC900-TRAY	COVER, SWEAT TRAY (OPTIONAL KIT)	1
29	MAN-VC1-0A-35	MANUAL, VC1-0A-35	1

***NOTE:** These parts come preassembled onto other parts.

****NOTE:** These parts are included in the hardware pack.

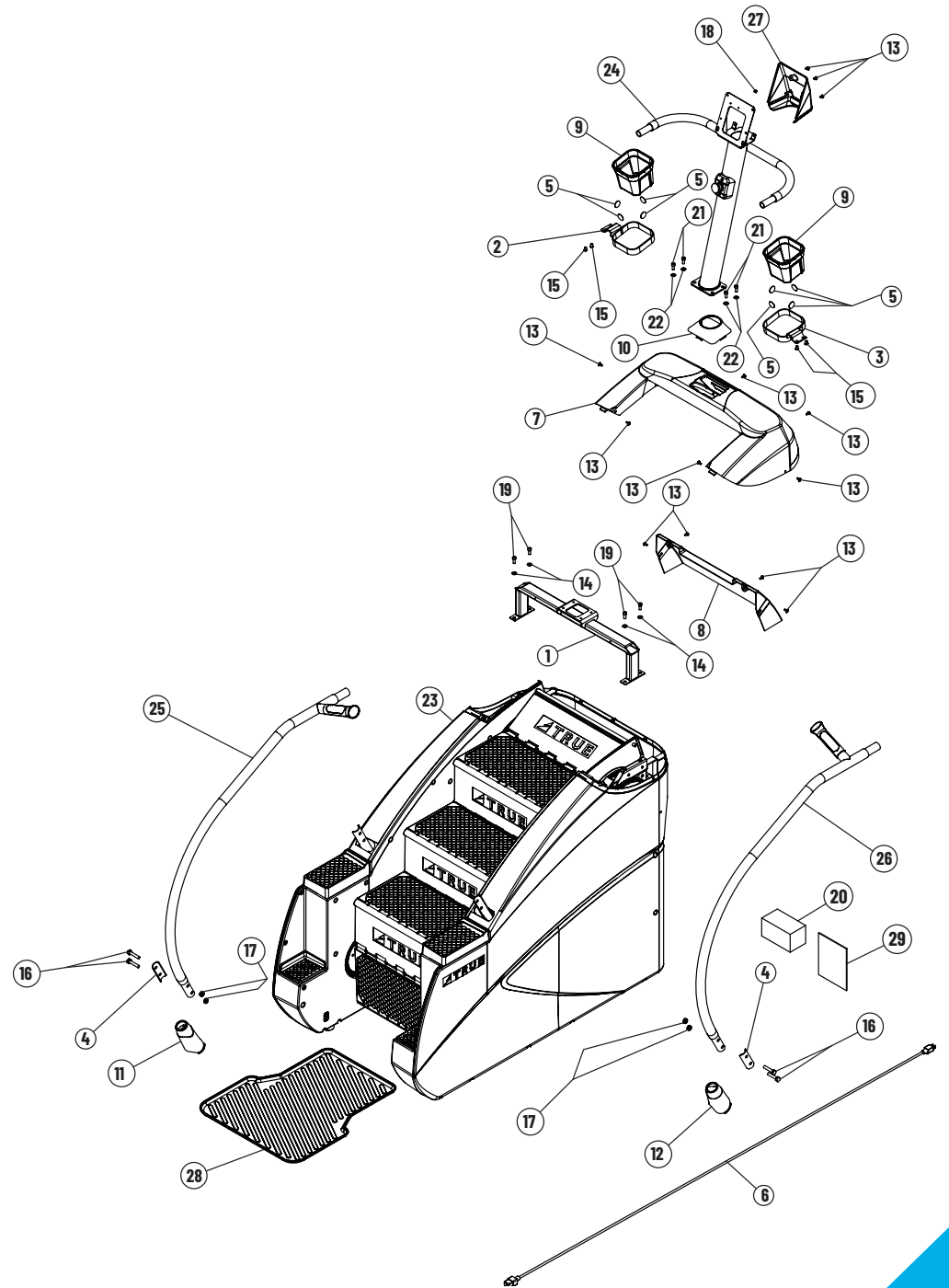

HARDWARE PACK CONTENTS

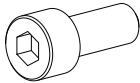
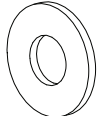
Step 1 Hardware Used		
Part	Description	Qty
VC90176	SHCS, M8-1.25 X 20MM, BLK ZP 	4
VC90151	WASHER, FLAT, M8 X 18 OD X 1.5, BLK, ZP 	4

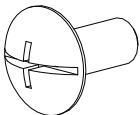
Step 2 Hardware Used		
Part	Description	Qty
VC90148	PHMS, M5-0.8 X 12MM, ZP 	4

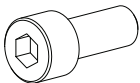
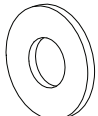
Step 3 Hardware Used		
Part	Description	Qty
VC90205	SHCS, M8-1.25 X 20MM, SS 	4
VC90206	WASHER, FLAT, M8 X 18 OD X 1.5, SS 	4

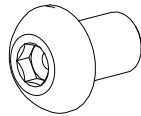
Step 5 Hardware Used		
Part	Description	Qty
VC90167	BHCS, M8-1.25 X 12MM, SS 	4

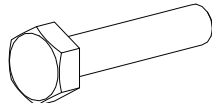
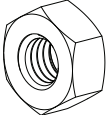
Step 6 Hardware Used		
Part	Description	Qty
VC90168	HHS, M10-1.50 X 50MM, NYLOC, BLK ZP 	4
VC90169	HEX NUT M10 X 1.5 X 8 BZ 	4

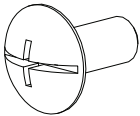
Step 8 Hardware Used		
Part	Description	Qty
VC90148	PHMS, M5-0.8 X 12MM, ZP 	3

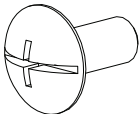
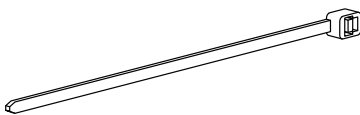
Step 10 Hardware Used		
Part	Description	Qty
VC90148	PHMS, M5-0.8 X 12MM, ZP 	7
00456100	CABLE TIE, 14.5" 	1

ASSEMBLY STEPS

Step 1—Attach the Upper Frame to the Base

Tools Used in this Step	
6mm Allen Wrench	

Parts Used in this Step			
Item	Part	Description	Qty
1	VC90003-35	WELDMENT, UPPER FRAME	1
2	VC90250-35	VC900 BASE ASSEMBLY	1
3	VC90176	SHCS, M8-1.25 X 20MM, BLK ZP	4
4	VC90151	WASHER, FLAT, M8 X 18 OD X 1.5, BLK, ZP	4

- A. Using the four M8 hex bolts, finger tight the upper frame to the base.
- B. When all four bolts are finger tight, use a 6mm allen wrench to fully tighten.

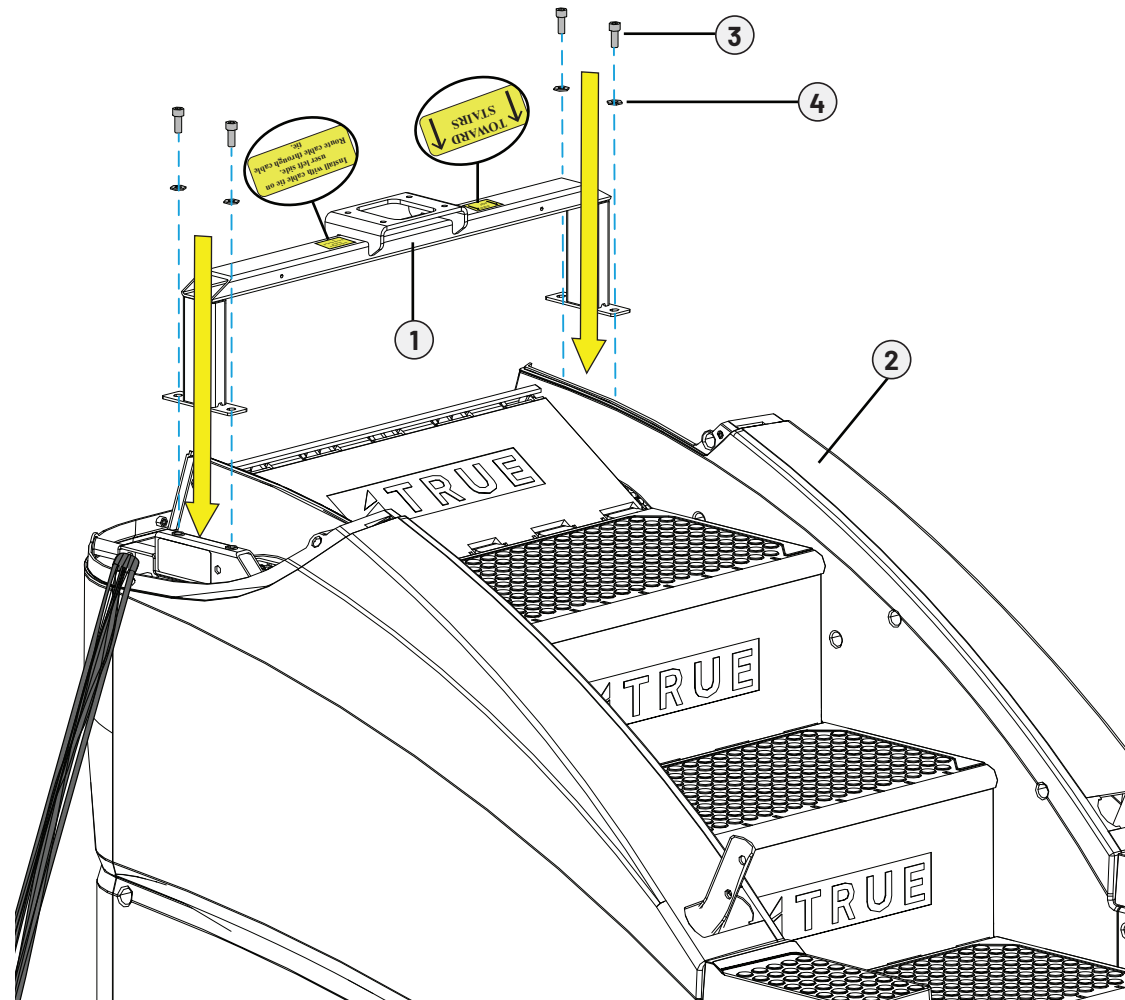

Step 2—Attach the Inner Guard Shroud to the Frame

Tools Used in this Step

#2 Phillips Screwdriver



- A. Be sure the cable bundle is pulled out of the base and carefully draped over the left side of the base.
- B. Attach the inner guard shroud to the base using four screws.

NOTE: It helps to partially thread each side screw and then slide the inner guard shroud over the two side screws to help hold it in place as you continue to install and tighten all screws.

Parts Used in this Step

Item	Part	Description	Qty
1	VC90003-35	WELDMENT, UPPER FRAME	1
2	VC90250-35	VC900 BASE ASSEMBLY	1
3	VC90103	SHROUD, INNER GUARD	1
4	VC90148	PHMS, M5-0.8 X 12MM, ZP	4

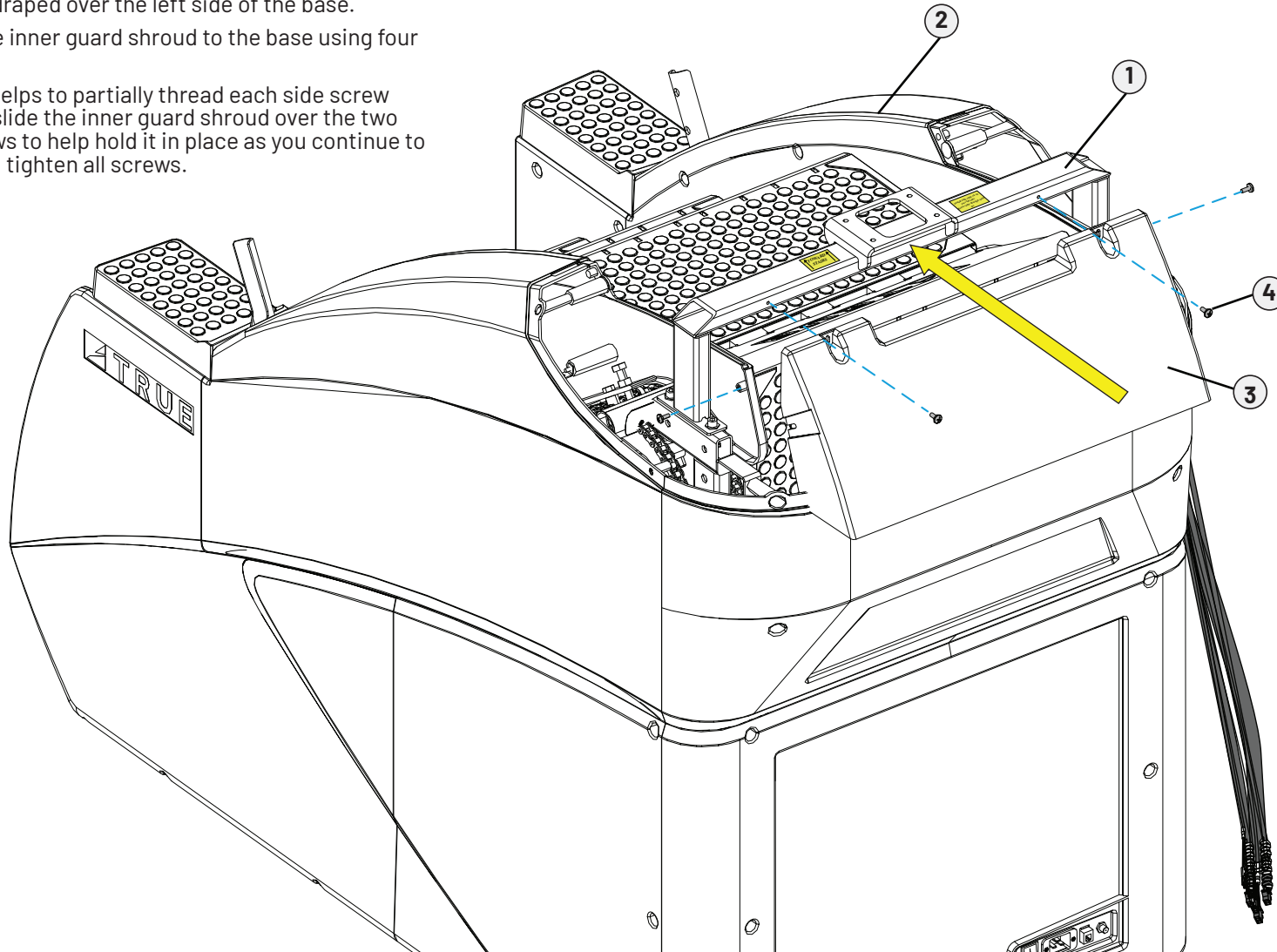

Step 3—Route Cables from Base up Console Mast and Attach Mast to Frame

Tools Used in this Step	
6mm Allen Wrench	

Parts Used in this Step			
Item	Part	Description	Qty
1	VC90003-35	WELDMENT, UPPER FRAME	1
2	VC90090	SHROUD, TOP, WITH DECAL	1
3	VC90112	COVER, MAST BASE	1
4	VC90251-35	SUBASSEMBLY, CONSOLE MAST, INTERNATIONAL	1
5	VC90205	SHCS, M8-1.25 X 20MM, SS	4
6	VC90206	WASHER, FLAT, M8 X 18 OD X 1.5, SS	4

- Push the mast cover up and then slide the top shroud onto the console mast.
- Route the base cables around the inner guard shroud, up through the hole of the upper frame, and through the console mast. To pull the cables through the console mast, use the provided pull string to attach the base cables to the inside of the console mast, and then pull the string/base cables up through the console mast.
- Attach the console mast to the upper frame. Finger tight the four M8 hex bolts, and then using a 6mm allen wrench, fasten securely.

CAUTION: Avoid damage to the cables. NEVER route cables near the steps or by any moving part of the machine.

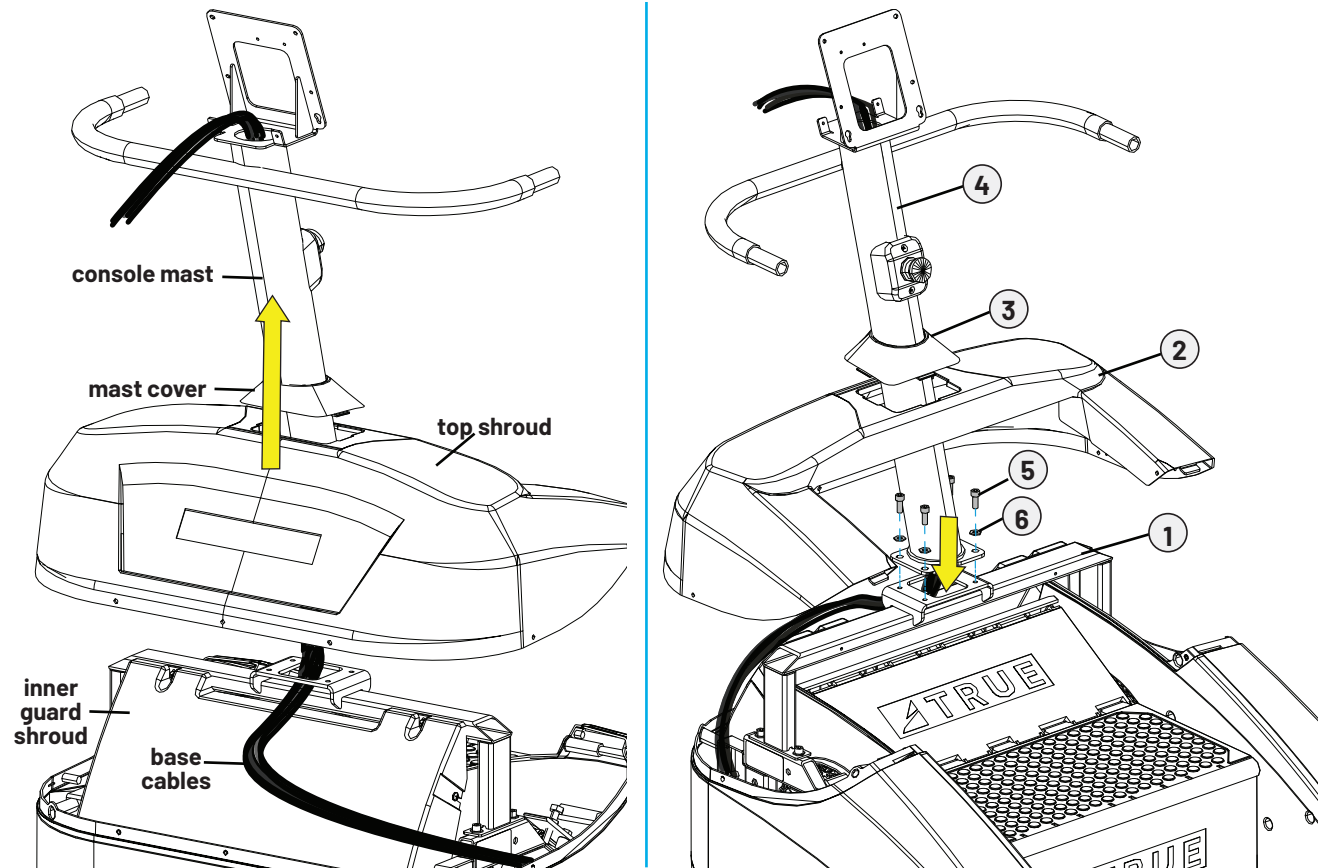
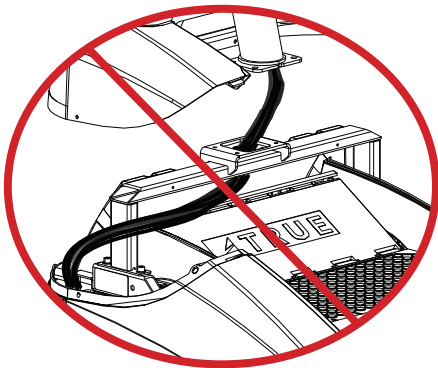

NOTE: You will be securing the cables to the frame with zip ties and then fastening the top shroud in step 10.

Step 4—Connect Handrail and Console Mast Cables

- A. Slide the handrail covers onto the handrails.

NOTE: Handrail covers are labeled left and right.

- B. Remove protective packaging and wire ties securing the cables on the console mast and handrails.
- C. Connect the contact heart rate and thumb switch cables between the handrails and console mast and then slide the handrails onto the console mast.

NOTE: To provide more slack to make the cable connections at the handrails, carefully push/pull the cables coming out of the console mast. Once the cables are connected, be sure to carefully route excess cable length back through the top of the console mast.

- D. Position the bottom of the handrails by the handrail mount brackets.

Parts Used in this Step			
Item	Part	Description	Qty
1	VC90251-35	SUBASSEMBLY, CONSOLE MAST, 30MM E-STOP	1
2	VC90254-35	ASSEMBLY, LEFT HANDRAIL & HR GRIP, FULL DIPPED	1
3	VC90255-35	ASSEMBLY, RIGHT HANDRAIL & HR GRIP, FULL DIPPED	1
4	VC90117	COVER, HANDRAIL BASE, LH	1
5	VC90118	COVER, HANDRAIL BASE, RH	1

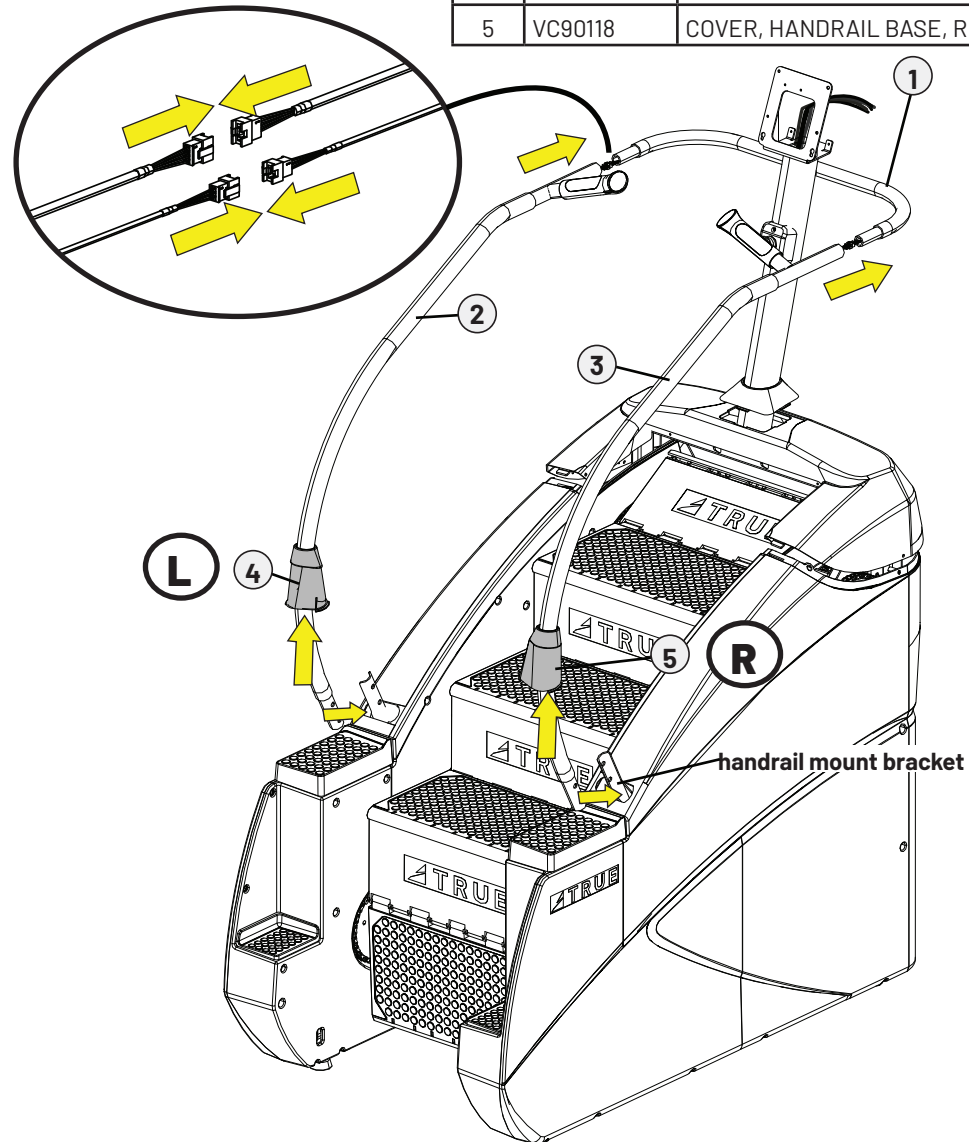

Step 5—Attach Cup Holder Rings

Tools Used in this Step	
5mm Allen Wrench	

Loosely fasten the cup holder rings to the console mast and handrails. **DO NOT** fully tighten the hardware until step 7.

NOTE: Cup holder rings are labeled left and right.

Parts Used in this Step			
Item	Part	Description	Qty
1	VC90251-35	SUBASSEMBLY, CONSOLE MAST, 30MM E-STOP	1
2	VC90254-35	ASSEMBLY, LEFT HANDRAIL & HR GRIP, FULL DIPPED	1
3	VC90255-35	ASSEMBLY, RIGHT HANDRAIL & HR GRIP, FULL DIPPED	1
4	VC90009-35	WELDMENT, CUP HOLDER RING, LH	1
5	VC90010-35	WELDMENT, CUP HOLDER RING, RH	1
6	VC90167	BHCS, M8-1.25 X 12MM, SS	4

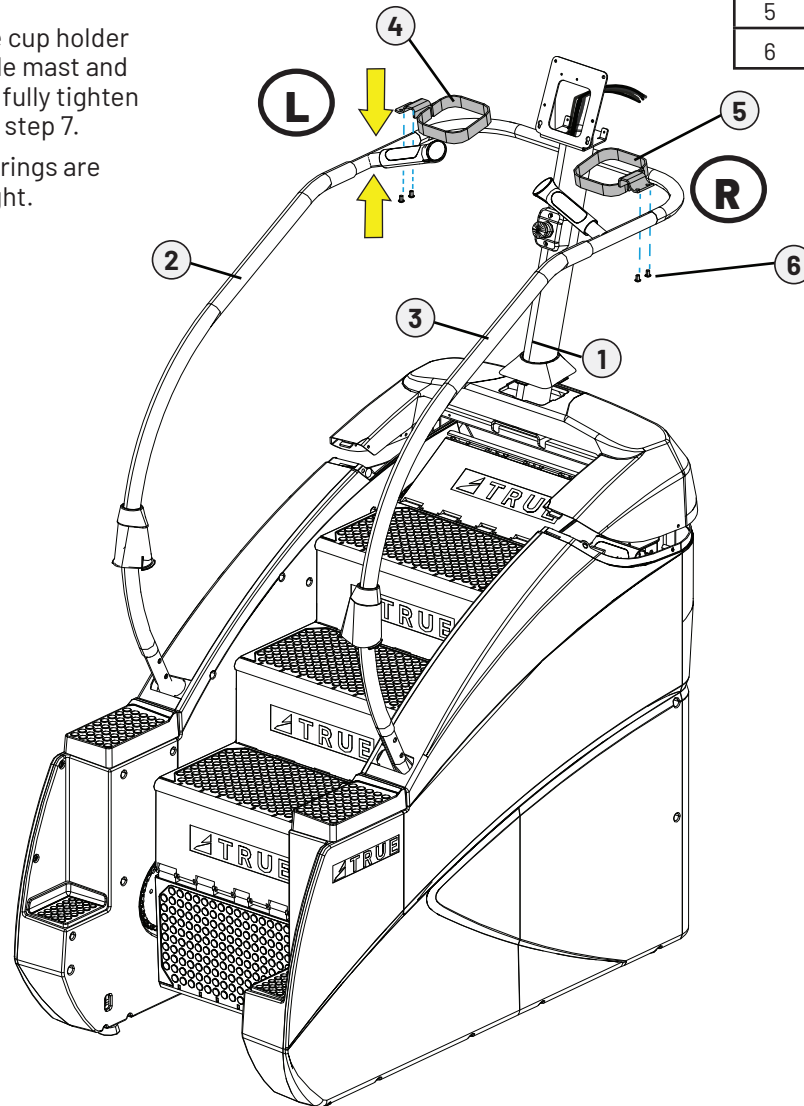

Step 6—Attach Handrails to Base Frame

Tools Used in this Step

17mm Wrench and 17mm
Socket Wrench

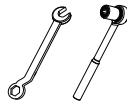

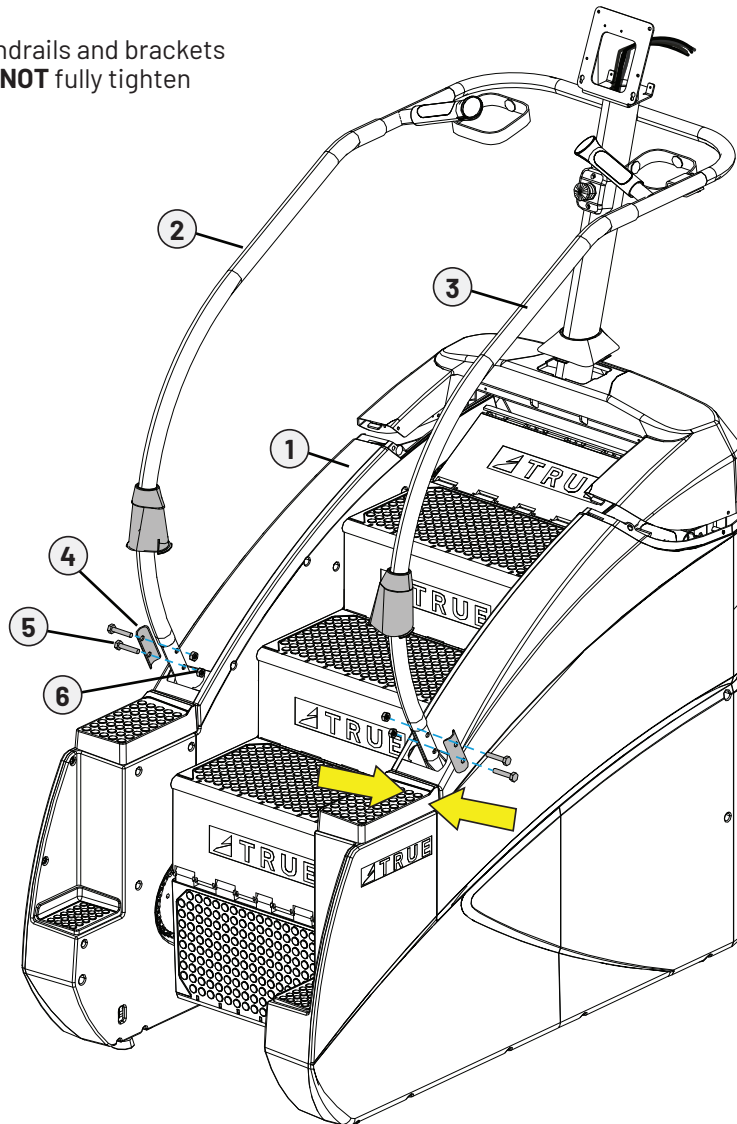

Loosely attach the handrails and brackets to the base frame. **DO NOT** fully tighten hardware until step 7.



Parts Used in this Step

Item	Part	Description	Qty
1	VC90250-35	VC900 BASE FRAME	1
2	VC90254-35	ASSEMBLY, LEFT HANDRAIL & HR GRIP, FULL DIPPED	1
3	VC90255-35	ASSEMBLY, RIGHT HANDRAIL & HR GRIP, FULL DIPPED	1
4	VC90019	BRACKET, HAND RAIL CLAMP	2
5	VC90168	HHS, M10-1.50 X 50MM, NYLOC, BLK ZP	4
6	VC90169	HEX NUT M10 X 1.5 X 8 BZ	4

Step 7—Tighten Hardware, Slide Covers in Place, and Insert Cup Holders

Tools Used in this Step	
17mm Wrench and 17mm Socket Wrench	
5mm Allen Wrench	

Parts Used in this Step			
Item	Part	Description	Qty
1	VC90250-35	VC900 BASE FRAME	1
2	VC90254-35	ASSEMBLY, LEFT HANDRAIL & HR GRIP, FULL DIPPED	1
3	VC90255-35	ASSEMBLY, RIGHT HANDRAIL & HR GRIP, FULL DIPPED	1
4	VC90117	COVER, HANDRAIL BASE, LH	1
5	VC90118	COVER, HANDRAIL BASE, RH	1
6	VC90111	PLASTIC, CUP HOLDER	2

- A. Using a 17mm wrench and socket wrench, securely fasten the handrails, and then slide the handrail covers down and tuck into the base.
- B. Using a 6mm allen wrench, securely fasten the cup holder rings, and then insert the cup holders into place.

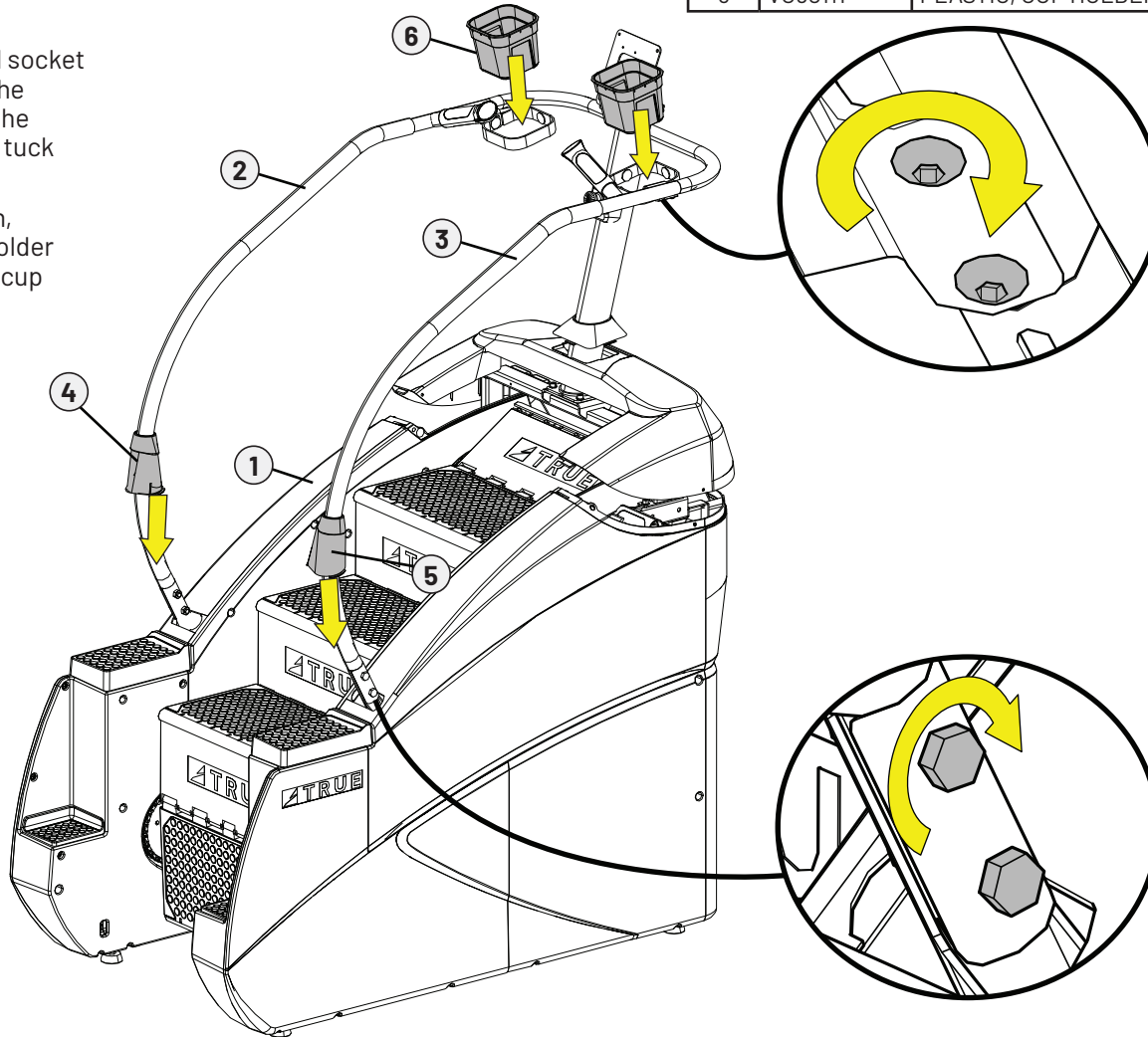

Step 8—Attach Console and Rear Console Cover

Tools Used in this Step	
#2 Phillips Screwdriver	

Parts Used in this Step			
Item	Part	Description	Qty
1	VC90110	COVER, CONSOLE REAR	1
2	VC90148	PHMS, M5-0.8 X 12MM, ZP	3
3	VC90175	PHMS, M5-0.8 X 6MM, ZP	1
4	N/A	CONSOLE	1

- A. If the console has three screws (00567700 // SCREW, M4-.7 X 12 PPHMS SEMS) preassembled, remove and set aside these screws. They are not used in this installation. Remove and set aside the top two screws (00567800 // SCREW, M5-.8X12 COMBO PHILLIPS/COMMON TRUSS HEAD - ACG BLACK) preassembled to the console. Slightly loosen the bottom two screws but leave them installed. All four screws will be used to secure the console to the mast in step C.

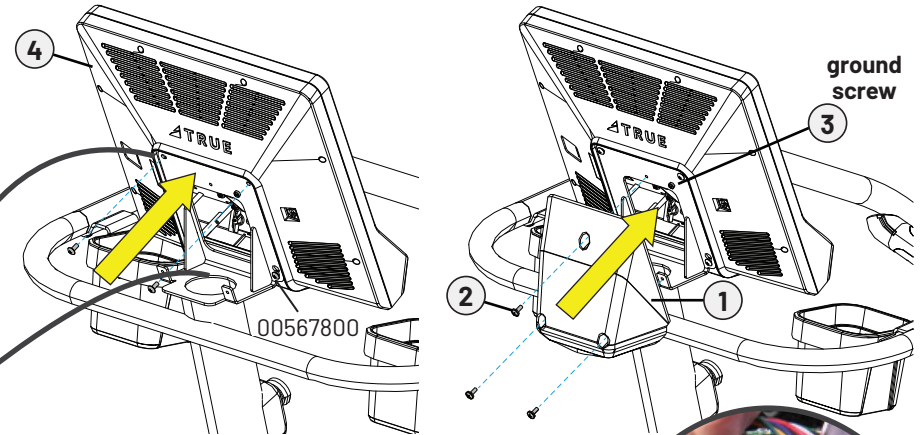
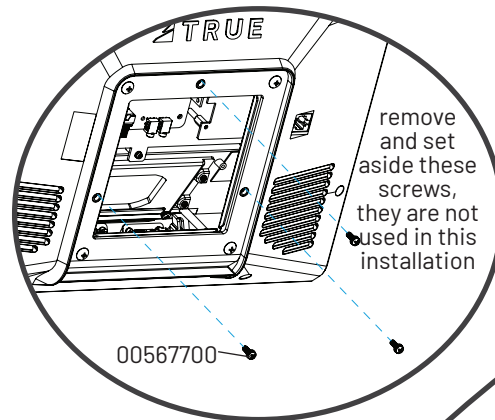

- B. Connect the console and base cables: network, coaxial, heart rate, button control, e-stop key, I/O data, power, and ground (attach the ground cables using the preassembled ground screw).

NOTE: The LED console does not use the coaxial or network cables. Those cables can be tucked back down the console mast.

Ensure all cables are routed inside the console mast to avoid pinching the cables

- C. Using a #2 Phillips screwdriver, secure the console to the console mast using the four screws (00567800).

- D. Using a #2 Phillips screwdriver, attach the rear console cover.

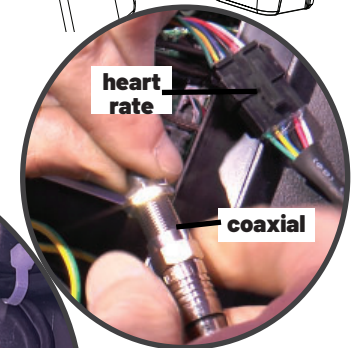
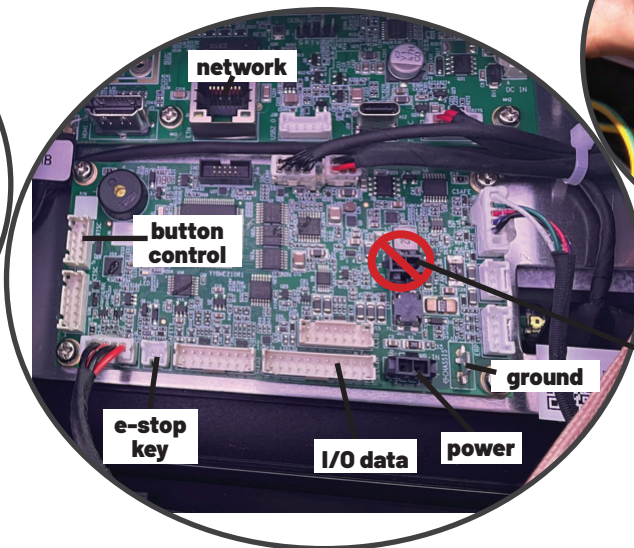
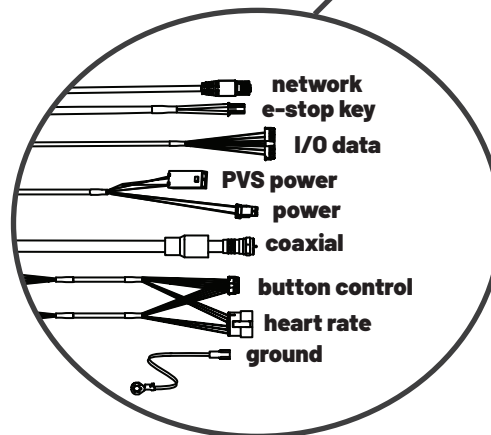

NOTE: Depending on the installation, PVS power may not be used.



Step 9—Attach Power Cord

Insert the power cord and power on the machine.
Verify the console powers up.

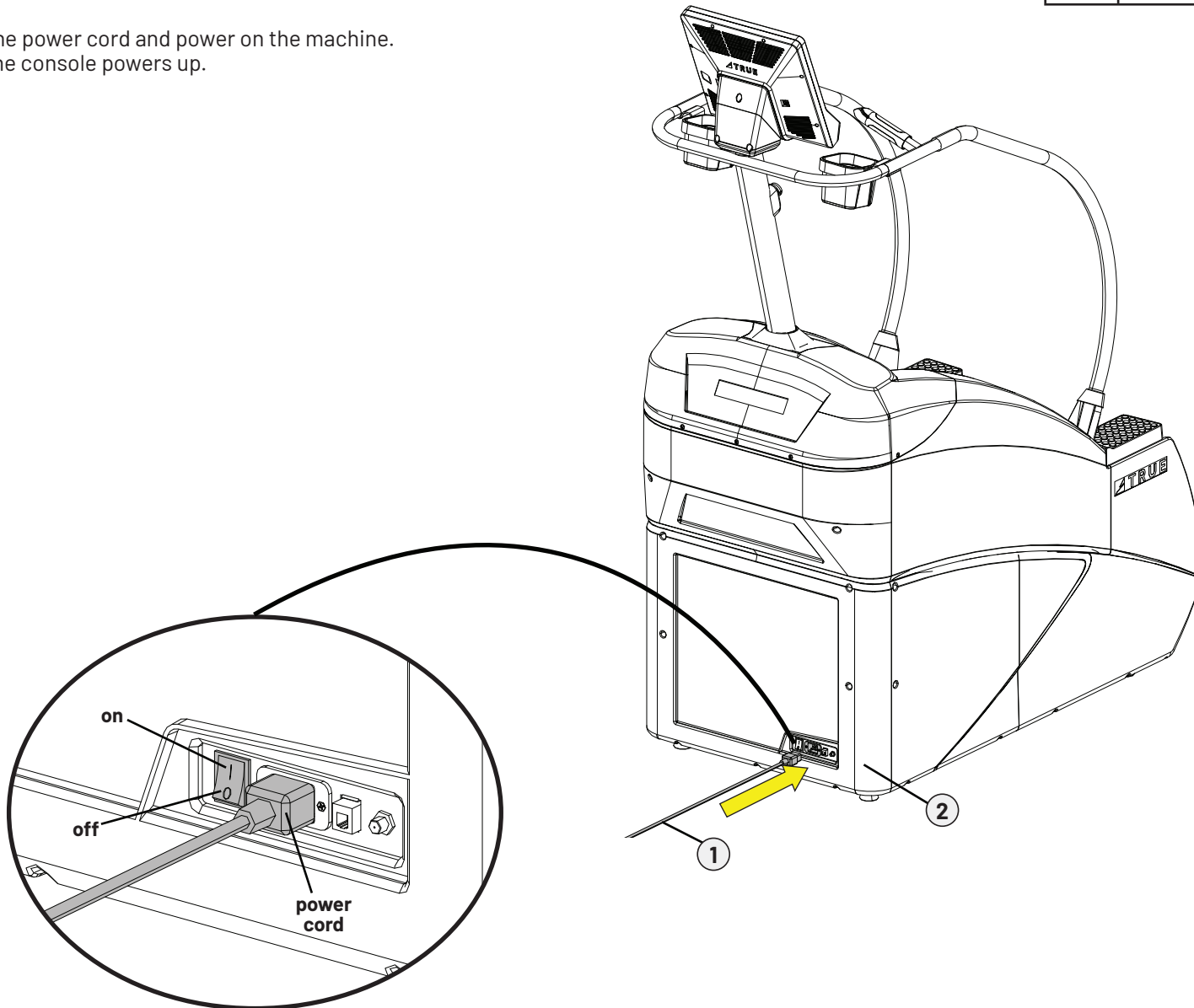
Parts Used in this Step			
Item	Part	Description	Qty
1	VC90080	CABLE, VC900 POWER	1
2	VC90250-35	VC900 BASE FRAME	1



Step 10—Secure Cables and Fasten Top Shroud

Tools Used in this Step	
#2 Phillips Screwdriver	
Wire Cutters	

- A. Using the cable tie provided, secure the base cables to the upper frame so they do not hang below the inner cover. Snip excess cable tie material.

⚠ CAUTION: Avoid damage to the cables. Always keep cables away from moving parts inside the machine.

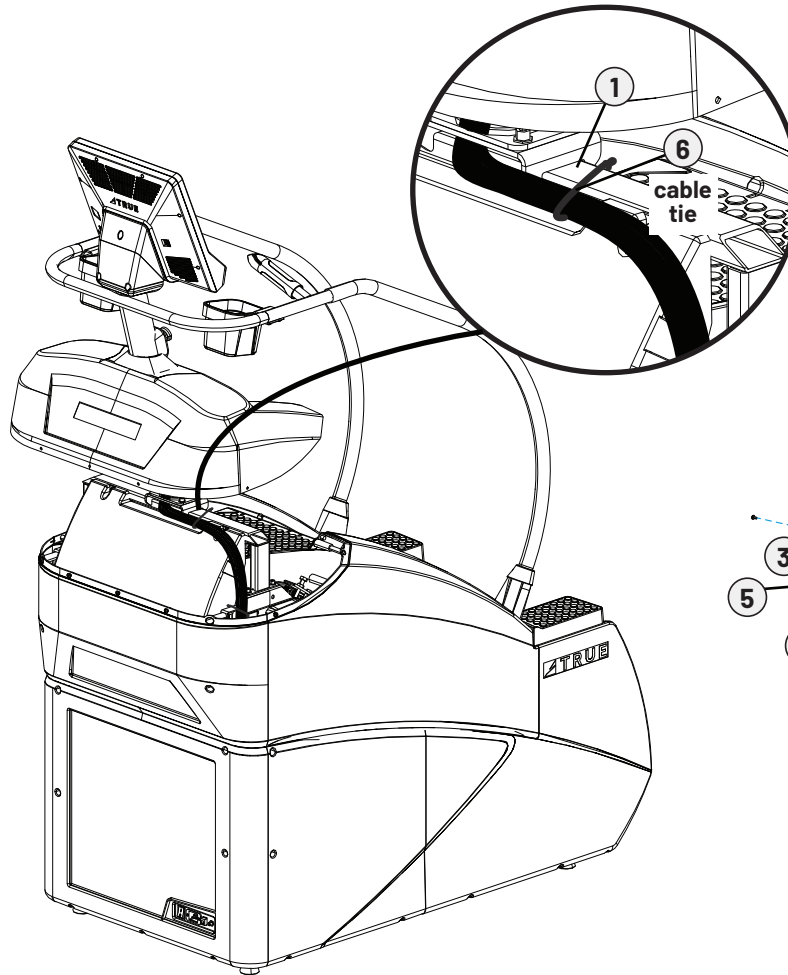

- B. Using a #2 Phillips screwdriver, secure the top shroud to the base.
- C. Tuck the mast base cover into the top shroud.

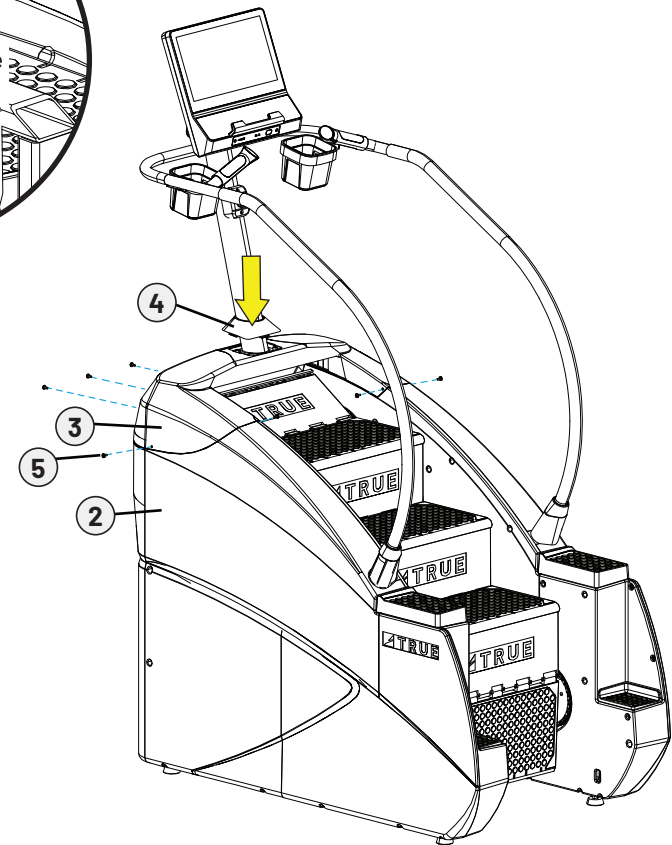

Parts Used in this Step			
Item	Part	Description	Qty
1	VC90003-35	WELDMENT, UPPER FRAME	1
2	VC90250-35	VC900 BASE FRAME	1
3	VC90090	SHROUD, TOP, WITH DECAL	1
4	VC90112	COVER, MAST BASE	1
5	VC90148	PHMS, M5-0.8 X 12MM, ZP	7
6	00456100	CABLE TIE, 14.5"	1



Step 11—Level the Machine

Tools Used in this Step	
17mm Wrench	
Level (recommended)	

- A. Adjust all four leveling feet until they contact the floor.

IMPORTANT! Do not adjust the leveling feet to such a height that they detach or unscrew from the machine.

- B. Using a 17mm wrench, verify all four lock nuts are securely tightened and flush against the bottom of the frame.

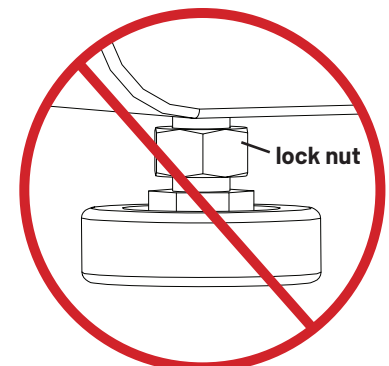
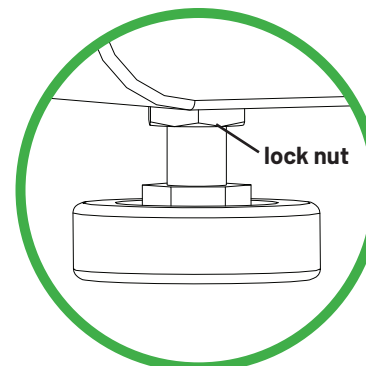
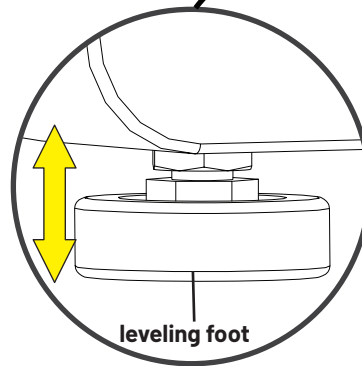
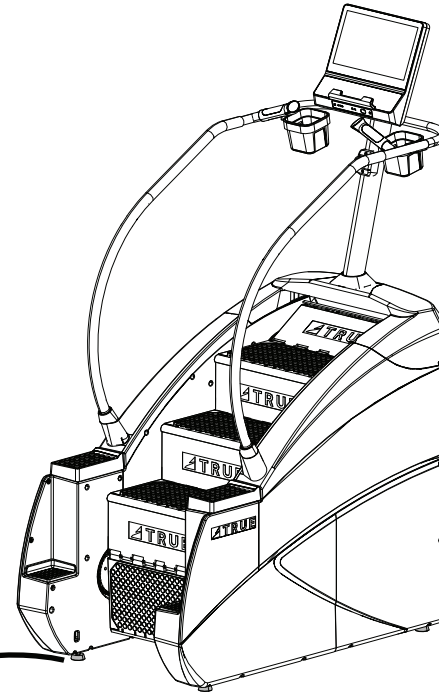

IMPORTANT STEP—DO NOT SKIP!

Step 12—Configure the Console with the Base and Run Calibration*

Please follow the instructions included with your console for important configuration and calibration steps.

Please contact product support right away if you run into issues setting up the machine:
800.883.8783 | service@truefitness.com | Monday–Friday 8:30am–5:00pm (CST)

***NOTE:** All new products require configuration. However, not all new products require calibration. Refer to the table below. If calibration is required, you must calibrate the machine.

PRODUCT CALIBRATION REQUIREMENTS		
REQUIRES CALIBRATION	DOES NOT REQUIRE CALIBRATION	
APEX TREADMILL	APEX ELLIPTICAL	GRAVITY CROSSTRAINER
GRAVITY TREADMILL PLUS	APEX CROSSTRAINER	GRAVITY RECUMBENT ELLIPTICAL
GRAVITY TREADMILL	APEX RECUMBENT BIKE	LAUNCH ELLIPTICAL
LAUNCH TREADMILL DC	APEX UPRIGHT BIKE	LAUNCH RECUMBENT BIKE
VAPOR STRYKER	APEX RECUMBENT ELLIPTICAL	LAUNCH UPRIGHT BIKE
VAPOR ALPINE RUNNER	GRAVITY ELLIPTICAL	VAPOR PALISADE
VAPOR SPECTRUM	GRAVITY RECUMBENT BIKE	VAPOR XT-ONE
	GRAVITY UPRIGHT BIKE	VAPOR LATERAL X

PRODUCT FEATURES

BASE OVERVIEW

- A. Console Assembly**
The console allows the user to set up a workout program and control the climber during a workout.
- B. Quick Access Keys**
Allows the user to quickly start, stop, and wake the climber or make fast, convenient adjustments to the speed of the climber.
- C. Contact Heart Rate Pads**
Allows the user to check their heart rate without wearing a wireless chest strap.
- D. Safety (E-Stop) Knob**
A safety stop knob permanently attached to the climber. Push the safety stop knob to stop the steps in motion to prevent injury in an emergency.
- E. On/Off Switch**
Allows users or faculty to turn the power on or off to the climber.
- F. Cup Holders**
Holds average size drink bottles for convenient use during a workout.
- G. Steps**
Moving part of the climber that user climbs to exercise.
- H. Power Cord**
Delivers power from the wall outlet to the climber.
- I. Handrails**
A place for users to put their hands during a workout and helps provide balance.
- J. Leveling Feet**
An adjustable system used to aid in the leveling the Slat Treadmill.



CONSOLE OVERVIEW

UNITE TOUCHSCREENS (16" SHOWN)

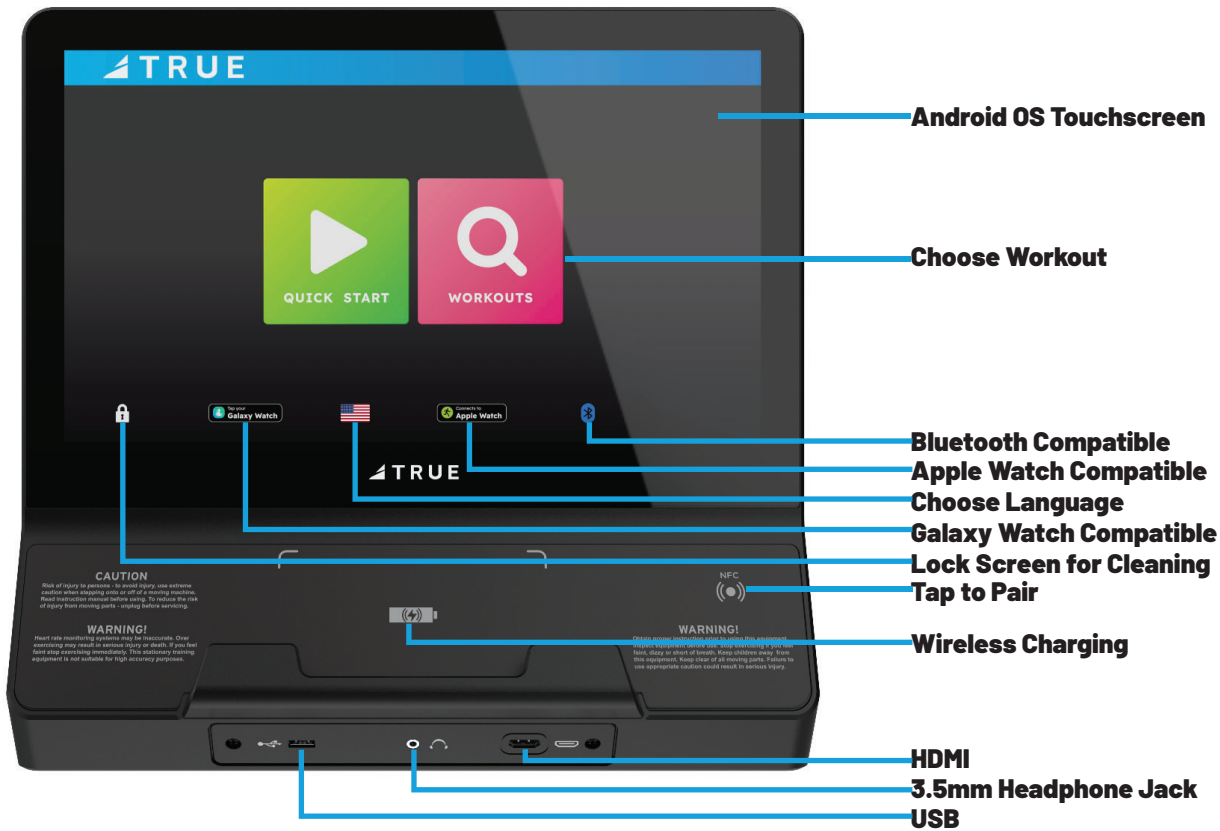

UNITE LED

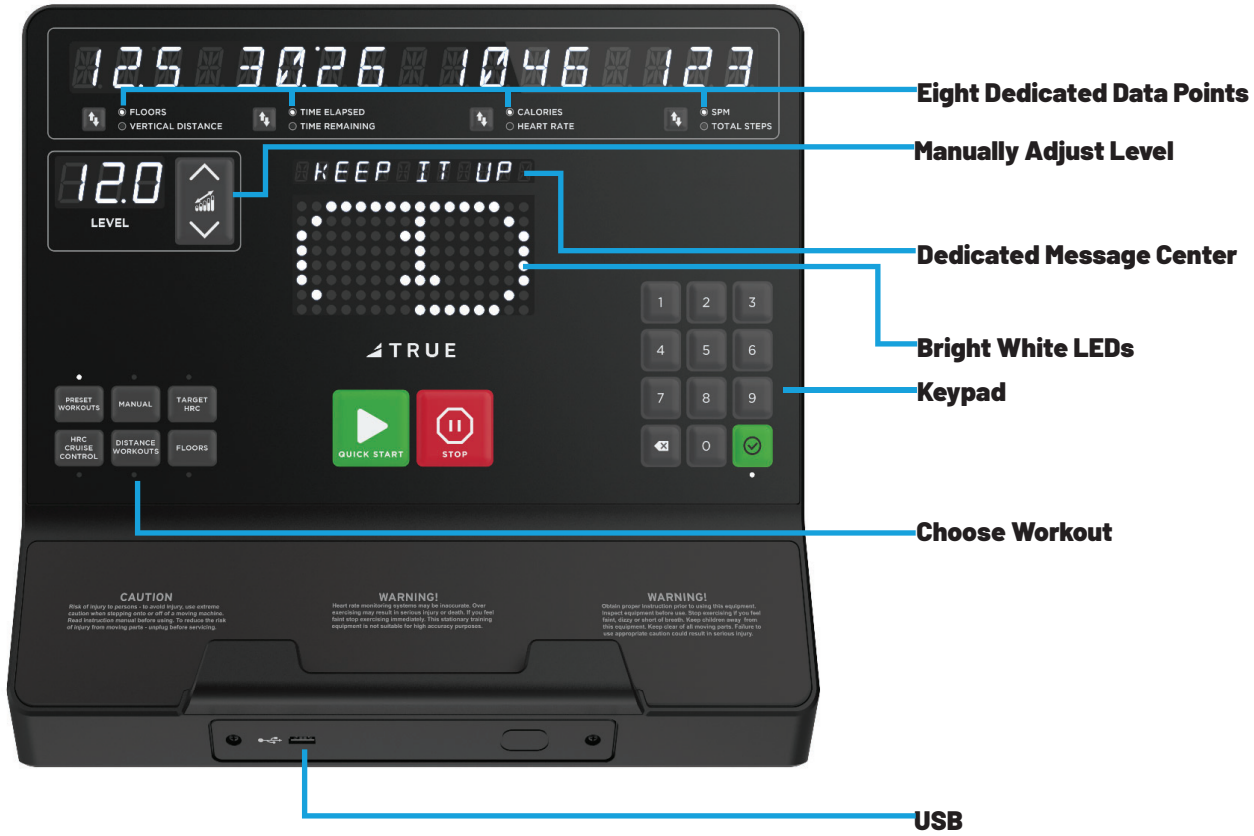

CARE AND MAINTENANCE

It is important to perform the minor maintenance tasks described in this section. Failure to maintain the equipment as described here could void the TRUE Fitness Warranty. To reduce the risk of electrical shock, always unplug the unit from its power source before cleaning or performing any maintenance tasks.

INSPECTION

TRUE is not responsible for performing or scheduling regular maintenance or inspections. Users should inspect the machine daily. Look and listen for loose fasteners, unusual noises, worn or frayed power cords, and any other indications that the equipment may be in need of service. If any of these are noticed, obtain service. Do not attempt to use the machine until proper service has been performed or damaged parts have been replaced.

IMPORTANT!

If you determine that the machine needs service, make sure it cannot be used inadvertently. Turn the unit off, and then unplug the power cord from its power source. Make sure other users know that the machine needs service. To order parts or to contact a TRUE authorized service representative, please visit www.truefitness.com.

CLEANING THE EQUIPMENT

AFTER EACH USE

- Use GymWipes™ Antibacterial wipes or spray a solution of 30 parts water to 1 part mild detergent to dampen a soft cloth and wipe all exposed surfaces.
- Use a LCD/screen cleaner or spray a solution of 1 part 91% isopropyl alcohol and 1 part water to dampen a soft cloth and wipe the surface of the console. This helps remove fingerprints, dust, and dirt.

WEEKLY

- **Vacuum**—Vacuum any dust or dirt that might have accumulated under or around the machine. Clogged air vents can prevent adequate cooling, causing a shortened life.

⚠ CAUTION:

Do not use any acidic cleaners. Doing so will weaken the paint or powder coatings and may void the TRUE Fitness Warranty. Never pour water or spray liquids on any parts of the machine. Allow the machine to dry completely before using. Frequently vacuum the floor underneath the unit to prevent the accumulation of dust and dirt, which can affect the smooth operation.

LEVELING THE MACHINE

⚠ CAUTION:

Prevent potential damage to the machine and injury to the user. This unit is equipped with adjustable leveling feet. Make sure that the machine is level at all times. If the machine is placed on a uneven surface, adjusting the feet can help, but may not completely compensate for extremely uneven surfaces. Machines that are not level can cause possible injuries for the user.

- A. Adjust all four leveling feet until they contact the floor.

IMPORTANT! Do not adjust the leveling feet to such a height that they detach or unscrew from the machine.

- B. Using a 17mm wrench, verify all four lock nuts are securely tightened and flush against the bottom of the frame.

PREVENTATIVE MAINTENANCE

TRUE recommends that quarterly scheduled maintenance be performed by a qualified service technician. Please contact your dealer or visit www.truefitness.com to contact a local TRUE authorized service technician.

IMPORTANT! Use only TRUE Fitness certified service providers. Using non-authorized service providers could void the TRUE Warranty.

Frequency	Tasks
Daily	<ul style="list-style-type: none">• Look and listen for loose fasteners, unusual noises, worn or frayed cables, and any other indications that the equipment may be in need of service.• Use GymWipes™ Antibacterial wipes or spray a solution of 30 parts water to 1 part mild detergent to dampen a soft cloth and wipe all exposed surfaces.• Use a LCD/screen cleaner or spray a solution of 1 part 91% isopropyl alcohol and 1 part water to dampen a soft cloth and wipe the surface of the console. This helps remove fingerprints, dust, and dirt.
Weekly	<ul style="list-style-type: none">• Vacuum any dust or dirt that might have accumulated under or around the machine.
Quarterly	<ul style="list-style-type: none">• Record time, distance, and hours from the console.• Check error log in console.• Remove shroud covers and vacuum any debris out of the speed sensor, control electronics and moving parts.• Move and vacuum underneath the machine.• Inspect all fasteners.• Inspect all electrical connections.• Inspect components for abnormal or premature wear.

LONG TERM STORAGE

When the machine is not in use for any length of time, turn it off. Make sure that the power cord is unplugged from the power source and is positioned so that it will not become damaged or interfere with people or other equipment.

CLEANING AND STORING THE CHEST STRAP

Clean the chest strap using a sponge or soft cloth dampened in mild soap and water. Dry the surface thoroughly with a clean towel. Store the chest strap in a place where it remains free of dust and dirt. Be sure to protect the chest strap from extreme temperatures. Do not store it in a place that may be exposed to temperatures below 32° F (0° C).

ADDITIONAL INFORMATION

TROUBLESHOOTING

This troubleshooting information is intended to assist in diagnostics only and is not all inclusive. Technical specifications, error codes, and programming are subject to change without notice. TRUE accepts no liability for any damage or loss suffered by persons whom rely wholly or in part on any description or statement contained within this manual. Please visit www.truefitness.com to obtain the most recent version of all manuals and contact TRUE product support (800-883-8783) for assistance with troubleshooting and diagnostics.

Malfunction	Possible Cause	Corrective Action
No Power	Unit turned off	Verify the On/Off switch is at the ON position
	Damaged power cord	Replace power cord
	Power cord not fully seated in socket	Inspect power connection at the unit and outlet
	No power at outlet	Using a voltmeter verify power at outlet
	Motor control board damaged	Contact TRUE Product Support
Unit resets or pauses randomly	Damaged power cord	Replace power cord
	Power cord not fully seated in socket	Inspect power connection at the unit and outlet
	Insufficient power	Verify output voltage from 20A outlet with a voltmeter
	Error code is displayed on console	Contact TRUE Product Support
	Pinched or loose main communication cable	
	Bad resistor (if unit shuts down or resets between level 5 and level 10)	Contact TRUE Product Support to replace resistor subassembly P/N 7VC90057
No TV displayed or low quality	Low or bad video signal	Contact video provider
		NTCS dBmV0 through 15.6 ATCS/QAM dBmV-10 through 15.5
	Loose F type connector (coaxial cable)	Inspect all connections
	Encrypted video	Obtain set top box from video provider
	Channels or format type not correct	Verify video type with provider; analog (NTCS), digital air (ATCS), digital cable (QAM)
		Rescan TV channels
Tuner Invalid	Contact TRUE Product Support	

Malfunction	Possible Cause	Corrective Action
Heart rate is displaying erratically or not displaying	Transmitter belt contacts are not making good contact with the skin	Re-adjust the transmitter belt so that it is in full contact with the skin
	Contacts on the transmitter belt are not moist	Moisten the contacts on the transmitter belt
	Transmitter belt is not within 3 feet (1 meter) of the heart rate receiver	Adjust your position on the belt so that you are within 3 feet (1 meter) of the console
	The battery inside the transmitter belt is depleted	Replace the transmitter belt with a compatible transmitter belt
	Another user wearing a compatible transmitter strap is within 3 foot (1 meter) of the unit	Move the units so that there is more space in-between units
	Environmental interference from high voltage power lines	Move the unit to another position within the room or move the cause of the interference until heart rate reading are stable. If the probable source of interference is plugged into the same outlet move the suspect source to another outlet.
	Environmental interference from computers	
	Environmental interference from motor driven appliances	
	Environmental interference from cell or cordless phone	
	Environmental interference from Wi-Fi router	
Contact Heart Rate not displaying	Machine needs to be restarted	Power cycle
	Cables are pinched or damaged	Contact TRUE product support
	Nucleus board may be damaged	Contact TRUE product support
	Heart Rate Grips may be damaged	Contact TRUE product support

WARRANTY INFORMATION

COMMERCIAL WARRANTY

CARDIO				
WARRANTY ITEM	VAPOR, APEX	GRAVITY PLUS	GRAVITY	ADX, RO, SURGE
Frame*	7 Years	7 Years	7 Years	5 Years
Parts	3 Years	3 Years	3 Years	3 Years
Consoles	3 Years	3 Years	3 Years	2 Years
Labor**	2 Years	2 Years	1 Year	1 Year
Wear Items***	180 Days	180 Days	180 Days	90 Days

FLEXIBILITY	
WARRANTY ITEM	STRETCH
Parts	1 Year
Wear Items***	90 Days

STRENGTH	
WARRANTY ITEM	PALLADIUM, FUSE XL, FORCE, FITNESS LINE, ATLAS, XFT, XFW, MP, SM, FT, FS
Frame*	10 Years
Parts	5 Years
Cables and Linear Bearings	1 Year
Labor**	1 Year
Wear Items***	90 Days

Warranty does not cover damage or equipment failure resulting from or caused by improper assembly/installation, accident, misuse, abuse, unauthorized modification, or failure to provide reasonable and necessary maintenance.

*Frame is the serialized base of the unit and does not include paint or coatings.

**Labor is available for equipment located within United States and Canada.

***Wear Items include: batteries, covers, caps, badges, paint, pedal straps, toe clips, elliptical pedal inserts, foot pads, Coax/TV, HDMI, USB, mirroring or Ethernet connections, and safety key.

See Warranty Details for terms, conditions, and complete coverage details.

LIMITED-USE COMMERCIAL WARRANTY*

CARDIO				
WARRANTY ITEM	VAPOR, APEX	GRAVITY PLUS	GRAVITY	LAUNCH
Frame***	7 Years	7 Years	7 Years	7 Years
Parts	5 Years	5 Years	5 Years	3 Years
Consoles	3 Years	3 Years	3 Years	3 Years
Labor****	3 Years	3 Years	2 Years	1 Year
Wear Items*****	180 Days	180 Days	180 Days	180 Days

IN-HOME USE WARRANTY**

CARDIO				
WARRANTY ITEM	VAPOR, APEX	GRAVITY PLUS	GRAVITY	LAUNCH
Frame***	12 Years	12 Years	12 Years	7 Years
Parts	10 Years	7 Years	7 Years	5 Years
Consoles	3 Years	3 Years	3 Years	3 Years
Labor****	2 Years	1 Year	1 Year	1 Year
Wear Items*****	180 Days	180 Days	180 Days	180 Days

TRUE Fitness may offer alternative warranties to purchasers of commercial equipment for limited-use commercial* or in-home use.** This policy ensures that customers who use commercial equipment for limited-use commercial or in-home use may receive alternative warranty coverage, provided they meet the specified requirements. It's important to note that the specific terms and conditions of the alternative warranty, as well as the eligibility criteria, may vary depending on the product and TRUE's policies at the time of purchase. Customers should review the warranty terms and contact TRUE for precise details.

*To be eligible for the alternative limited-use commercial warranty, equipment use cannot exceed 6-hours use a day or be for use in a membership, dues paying, or institutional facility.

**To be eligible for the alternative in-home use warranty, equipment must be registered to a home address and cannot be used outside of the purchaser of the equipment and their immediate family.

Customers must provide TRUE with the following within 30 days of installation of the commercial-rated equipment:

- Purchase agreement.
- Proof of professional delivery and installation.
- TRUE will register the alternative warranty for the purchaser and implement it within 90 days of receiving the required documentation if such an alternative warranty is available for the specific product.

Warranty does not cover damage or equipment failure resulting from or caused by improper assembly/installation, accident, misuse, abuse, unauthorized modification, or failure to provide reasonable and necessary maintenance.

***Frame is the serialized base of the unit and does not include paint or coatings.

****Labor is available for equipment located within United States and Canada.

*****Wear Items include: batteries, covers, caps, badges, paint, pedal straps, toe clips, elliptical pedal inserts, foot pads, Coax/TV, HDMI, USB, mirroring or Ethernet connections, and safety key.

See Warranty Details for terms, conditions, and complete coverage details.

WARRANTY DETAILS

All TRUE Fitness products are distributed by TRUE and are warranted to the original registered product purchaser and the parts of the TRUE product (the "Product") listed below, under normal use and service, shall be free of manufacturing defects in workmanship and materials only for the specified period of time.

NOTE:

- Standard shipping is included with warranty part replacement.
- Shipping for warranty frame or replacement is included for the period of three years from the original date of purchase.

All Warranty Items are "LIMITED"

- This limited warranty does not cover damage or equipment failure resulting from or caused by improper assembly/installation, failure to follow instructions and warnings in owner's manual, accident, misuse, abuse, unauthorized modification, failure to provide reasonable and necessary maintenance, software version upgrades, compatibility with third party/aftermarket hardware, software, applications, or websites.
- TRUE's liability shall under no circumstances exceed the actual amount paid by you for the product, nor shall TRUE under any circumstances be liable for any consequential, incidental, special or punitive damages or losses, whether direct or indirect.
- Some states or countries do not allow the exclusion or limitation of incidental or consequential damages, so the above limitation or exclusion may not apply to you.
- TRUE will neither assume nor authorize any person to assure for us any other obligation or liability concerning the sale of this Product. Under no circumstances shall TRUE be liable under this warranty, or otherwise, of any damage to any person or property, including any lost profits or lost savings, for any special, indirect, secondary, incidental, or consequential damages arising out of the use of or inability to use this Product.
- This limited warranty, which is given expressly and in lieu of all other express warranties, constitutes the only warranty made by TRUE.
- The remedies described herein are your sole and exclusive remedies and TRUE's entire liability for any breach of this limited warranty.
- No one is authorized to change, modify, or extend the terms of this limited warranty.
- This limited warranty is in lieu of all other warranties of any kind either expressed or including but not limited to implied warranties of merchant.
- This limited warranty applies to the product only while the product remains in the possession of the original purchaser and is not transferable.
- This limited warranty becomes VALID ONLY if the Product is initially assembled/installed by a TRUE authorized dealer/technician (if anyone other than a TRUE authorized dealer/technician initially assembles and installs the Product, this limited warranty will be void unless the written authorization of TRUE is first obtained).
- This limited warranty can be processed only if the warranty registration form is completed on-line; or if the form provided with equipment is filled in, signed by the original purchaser, and mailed to TRUE within 30 days of purchaser's receipt of this Product.
- All serial numbers must be intact on the Product for this limited warranty to be valid.
- Installation or download of any 3rd party or after-market products will result in voided warranty. This includes, but is not limited to, electrical and mechanical parts, software, or applications.
- TRUE will ship to an authorized service provider any new or rebuilt replacement part or component, or at our option, replace or refund the Product.
- Replacement parts are warranted for the remaining portion of the original warranty period.
- Proof/receipts of necessary maintenance may be required within 30 days of requested warranty part or service.
- This limited warranty does not apply to the performance of the heart rate accuracy will not be warranted as performance varies, based on user's physiology, age, method of use, and other external factors.

WARRANTY REGISTRATION

Thank you for purchasing a TRUE product!

For warranty terms and conditions, see the complete owner's manual and assembly guide located at truefitness.com.



To validate your product warranty, you must register your product within 30 days of purchaser's receipt of this product.

To register your product:

- Go online to: <https://truefitness.com/services-support/warranty-registration/>
OR
- Complete the information below and mail to:
TRUE Product Support
865 Hoff Road
St. Louis, MO 63366

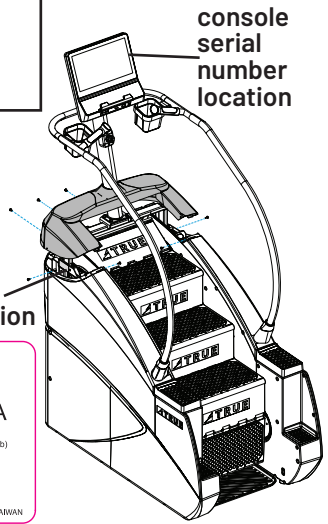
PLEASE RETAIN THIS PORTION FOR YOUR RECORDS
BASE SERIAL NUMBER:
CONSOLE SERIAL NUMBER:



TRUE FITNESS	Model No.	VC1-0A-35
TRUE FITNESS TECHNOLOGY, INC. 865 HOFF RD, ST. LOUIS, MO 63366, USA	Serial No./Date Code	24-VC10A0001A
  	PRODUCT: Climber	MAXIMUM USER WEIGHT: 182kg (400lb)
 CONFORMS TO ANSI/UL STD. 1641	CERTIFIED TO CAN/CSA STD. C22.2 NO.68	RATING: 100-240V, 40/60Hz, 25W
Intertek 3135202	Intertek Testing Services Taiwan Ltd.	MADE IN TAIWAN



WARRANTY REGISTRATION

Base Serial Number

Console Serial Number

Purchase Date

Company (if applicable)

Customer Name (First and Last)

Email Address

Phone Number

Street Address

City

State

Postal Code

Country



CONTACT US
service@truefitness.com
800.883.8783

865 Hoff Road
St. Louis, MO 63366

[TRUEFITNESS.COM](https://www.truefitness.com)



MAN-VC1-0A-35 Owner's Manual and Assembly Guide REV02

© 2024 TRUE Fitness All Rights Reserved.