

 **TRUE FITNESS**



LAUNCH TREADMILL

OWNER'S MANUAL AND ASSEMBLY GUIDE

IMPORTANT—PLEASE READ

All products shown are prototype. Actual product delivered may vary. Product specifications, features, and software are subject to change without notice.

For the most up-to-date version of this manual, please see our website: <https://truefitness.com/services-support/user-manuals/>

CONTACTING OUR SUPPORT TEAM

To contact TRUE for any of your pre or post installation questions, please call our toll-free numbers Monday - Friday 8:30am - 5:00pm (CST):

- Commercial Direct Customers and Corporate Accounts | 800.868.8783
- Retail Customers and Distributors | 800.883.8783

Or email us:

- Commercial Direct Customers and Corporate Accounts | service.direct@truefitness.com
- Retail Customers and Distributors | service@truefitness.com
- Service International | int.service@truefitness.com

When contacting TRUE, please have the following information ready:

- Serial Number of Unit
- Contact Information—Full Name, Email, and Phone Number
- Address of Facility or Residence
- Detailed Description Regarding Symptom of the Unit (along with pictures or video if applicable)

NOTE: Authorized service providers, dealers, and distributors may also use TRUE's online resource | portal.truefitness.com.

CONTACTING OUR SALES TEAM

Interested in owning more TRUE products? Please contact us with any product inquires so that we may direct you to the appropriate sales representative to help answer your questions.

- Phone | 800.426.6570
- Email | sales@truefitness.com
- Hours | Monday - Friday 8:30am - 5:00pm (CST)

REPORTING FREIGHT CLAIMS OR PARTS DAMAGE

Unfortunately, sometimes materials can be damaged during shipment. If materials are damaged during shipment, please follow the guidelines below to determine the appropriate process for you to follow.

Severe Damage—Obvious damage to external packaging and internal product.

Please refuse the shipment and it will be returned to TRUE by the carrier. Contact TRUE product support by calling 800.883.8783 or sales support by calling 800.426.6570 Monday–Friday during normal business hours to notify us that the shipment has been refused. Once we have received the damaged shipment, a replacement shipment will be sent to you. If the shipment comes in multiple boxes, only refuse boxes with damage.

Slight Damage—Minimal damage to external packaging with unknown internal damage to product.

If the shipment has minimal damages and you are not sure if the actual product is damaged, you must sign the bill of lading as damaged when accepting the shipment. Once you have opened the box and you have determined something is indeed damaged, please gather the serial number, model number, description of damage, and photos of damage. Please make sure the photos include the damaged product as well as the damaged box the product arrived in. Contact TRUE product support (service@truefitness.com | 800.883.8783) or TRUE sales support (sales@truefitness.com | 800.426.6570) Monday–Friday during normal business hours.

Concealed Damage—No damage to external packaging but internal damage to product.

You may receive a shipment that looks intact and discover once the box has been opened that there are hidden damages. Please notify the carrier immediately. TRUE will not be able to file a claim if the carrier is not notified in a timely manner. Once you have called the carrier you will need to gather the serial number, model number, description of damage, and photos of damage. Contact TRUE product support (service@truefitness.com | 800.883.8783) or TRUE sales support (sales@truefitness.com | 800.426.6570) Monday–Friday during normal business hours.

TABLE OF CONTENTS

SAFETY INSTRUCTIONS

IMPORTANT SAFETY INSTRUCTIONS—SAVE THESE INSTRUCTIONS.....	5
POWER REQUIREMENTS.....	7
SPACE REQUIREMENTS.....	8
SPECIFICATIONS.....	8
WARNING DECALS.....	9
COMPLIANCES.....	9
PROPER TRAINING POSITION AND TREADMILL SAFETY.....	9

ASSEMBLY INSTRUCTIONS

PREASSEMBLY CHECKLIST.....	10
ASSEMBLY STEPS.....	12

PRODUCT FEATURES

BASE OVERVIEW.....	25
CONSOLE OVERVIEW.....	26

CARE AND MAINTENANCE

INSPECTION.....	28
CLEANING THE EQUIPMENT.....	28
LEVELING THE MACHINE.....	29
RUNNING BELT ALIGNMENT.....	30
TENSIONING THE RUNNING BELT.....	31
LUBRICATING THE TREADMILL.....	32
PREVENTATIVE MAINTENANCE.....	33
LONG TERM STORAGE.....	33

ADDITIONAL INFORMATION

TROUBLESHOOTING.....	34
WIRING DIAGRAM.....	36

WARRANTY INFORMATION

COMMERCIAL WARRANTY.....	37
LIMITED-USE COMMERCIAL WARRANTY.....	38
IN-HOME USE WARRANTY.....	38
WARRANTY DETAILS.....	39
WARRANTY REGISTRATION.....	40

SAFETY INSTRUCTIONS

IMPORTANT SAFETY INSTRUCTIONS—SAVE THESE INSTRUCTIONS

This equipment is intended for a commercial or institutional setting. This owner's manual should be accessible to all personal trainers, faculty, and members.

- Read and understand all instructions and warnings prior to use.
- Obtain a medical exam before beginning any exercise program. If at any time during exercise you feel faint, dizzy, or experience pain, stop and consult your physician.
- Obtain proper instruction prior to use.
- This unit is intended for commercial use only.
- Inspect the unit for incorrect, worn, or loose components and do not use until corrected, replaced, or tightened prior to use.
- Do not wear loose or dangling clothing while using the unit.
- Care should be used when mounting or dismounting the unit.
- Read, understand, and test the emergency stop procedures before use.
- Disconnect all power before servicing the unit.
- Do not exceed maximum user weight of 400 lbs / 181 kg.
- Keep the top side of the moving surface clean and dry.
- Keep children and animals away.
- Use caution when moving and assembling unit.
- All exercise equipment is potentially hazardous. If attention is not paid to the conditions of equipment usage, death, or serious injury could occur.

⚠ DANGER: To reduce the risk of electric shock, always unplug this product when not in use, before cleaning, or attempting any maintenance activity. Do not handle the plug with wet hands.

⚠ WARNING: To reduce the risk of burns, fire, and electric shock or injury to persons, follow these instructions:

- Heart rate monitoring systems may be inaccurate. Over-exercising may result in serious injury or death. If you feel faint, dizzy, or experience pain, stop exercising immediately.
- Health related injuries may result from incorrect or excessive use of exercise equipment.
- TRUE STRONGLY recommends seeing a physician for a complete medical exam before undertaking an exercise program, particularly if the user has a family history of high blood pressure or heart disease, is over the age of 45, smokes, has high cholesterol, is obese or has not exercised regularly in the past year. Additionally, TRUE recommends consulting a fitness professional on the correct use of this product.
- Equipment should be immediately taken out of use if it fails to work properly or when a warning is presented electronically.
- When using this exercise machine, basic precautions should always be followed.
- Use this equipment only for its intended use as described in this manual.
- Do not move the equipment by lifting the console. Do not use the console as a handlebar during a workout.
- This product can expose you to chemicals including Toluene and Acrylamide which are known to the State of California to cause Cancer and birth defects or other reproductive harm. For more information, go to www.P65Warnings.ca.gov.
- Keep equipment stable on flat ground.
- Risk of personal injury—crushing hazard when equipment is in operation. Keep feet, hands, and fingers away from moving parts.
- Replace warning labels that may be worn, damaged, or missing.
- Replace any non-working or damaged components, remove the unit from service until repair is performed.
- Do not operate the equipment while being covered with a blanket, pillow, plastic, or anything that insulates or stops airflow. Keep air openings free of lint, hair or any obstructing material.
- To avoid serious injury, remove and store the power cord when the machine is not in use.
- This appliance should never be left unattended when plugged in.
- Do not use any type of extension cord with this product.
- Never operate a TRUE product if it has a damaged power cord or electrical plug, or if it has been dropped, damaged, or even partially immersed in water.
- Use a TRUE AC power cord or AC/DC adapter only.
- Position this product so the power cord plug is accessible to the user.

- Keep the power cord away from heated surfaces. Do not pull the equipment by the power cord or use the cord as a handle. Do not run the power cord along the side or under the equipment.
- If the electrical supply cord is damaged it must be replaced by the manufacturer, an authorized service agent, or a similarly qualified person to avoid a hazard.
- This product must be connected to a properly grounded electrical outlet.
- To disconnect, turn power OFF at the ON/OFF switch if applicable, then remove plug from electrical outlet. On the machine power switch, (I) means that the machine power is **ON** and (O) means the machine power is **OFF**.
- Never insert objects into any openings in this product. If an object should drop inside, turn off the power, unplug the power cord from the outlet and carefully retrieve it. If the item cannot be reached, contact TRUE product support.
- Any changes or modifications to this equipment could void the product warranty.
- Do not use this product in areas where aerosol spray products are being used or where oxygen is being administered. Such substances create the danger of combustion and explosion.
- Do not use this product outdoors, near water, while wet, or in areas of high humidity including extreme temperature changes.
- Close supervision is necessary when used near children under the age of 15, or disabled persons.
- This equipment is not intended for use by persons with reduced physical, sensory, or mental capabilities, or lack of experience and knowledge, unless they are supervised or have been given instruction concerning use of the equipment by a person responsible for their safety.
- Children shall not play with the appliance.
- Cleaning and user maintenance shall not be made by children without supervision.
- Wear shoes with rubber or high traction soles. Do not use shoes with heels, leather soles, cleats or spikes. Make sure no stones are embedded in the soles. Do not use this product in bare feet. Keep all loose clothing, shoelaces and towels away from moving parts.
- Do not use if you have a cold or fever.
- To avoid injury, attach the safety clip to clothing before use.
- When mounting the treadmill, ensure the treadmill belt is not running.
- Use handlebars to maintain balance when mounting and dismounting the treadmill and for additional stability while exercising.
- To avoid injury, stand on the side rails before starting the equipment.
- While the treadmill is in use, proceed at a speed that the user can safely maintain with the ability to immediately engage the safety key to stop the treadmill belt if necessary.
- Avoid the possibility of bystanders being struck or caught between moving parts by making sure that they are out of reach of the equipment while it is in motion.
- Do not use typing or web surfing features at excessive speeds. Always stabilize yourself when using typing or web surfing features. (Varies by console option.)
- Never place liquids of any type directly on the unit except in the accessory tray or bottle holders. Containers with lids are recommended.
- Always follow the console instructions for proper operation.
- Do not use the contact heart rate grips as a handlebar during a workout.
- Avoid exiting equipment while leaving the tread belt in motion.
- Never walk or jog backwards on the equipment.
- Allow only one person at a time on the equipment while it's operating.
- Do not allow animals on or near the equipment while in operation.
- To avoid serious injury, do not touch the incline rack while the equipment is in use.
- To avoid serious injury, do not touch the belt while the equipment is in use.
- Do not reach into or underneath the unit, or tip it on its side during operation.
- Do not change the incline of the equipment by placing objects under it.
- Do not use attachments not recommended by the manufacturer.
- Allow only trained personnel to service this equipment.
- It is the sole responsibility of the owner/operator to ensure regular and scheduled maintenance is performed.
- Do not remove the motor cover or you may risk injury due to electric shock. Please contact TRUE product support if the motor area needs servicing.
- Noise emission under load is higher than without load. A-weighted emission sound pressure level at the trainer's ear: 67 dBA.

POWER REQUIREMENTS

Read and understand all instructions before plugging any TRUE power cord into an electrical outlet.

DEDICATED LINE

This product requires a dedicated line without GFCI (Ground-Fault Circuit Interrupter) or AFCI (Arc-Fault Circuit Interrupter). GFCI and AFCI protection is not required for receptacles on a dedicated branch circuit located and identified for a cord-and-plug-connected appliance, such as a treadmill. A dedicated line assures that adequate power is available for safe operation over the life of your TRUE product.

GROUNDING INSTRUCTIONS

This product must be grounded. If the product malfunctions or breakdowns, grounding provides a path of least resistance for electric current to reduce the risk of electric shock. This product is equipped with a cord having an equipment grounding conductor and a grounding plug. The plug must be plugged into an appropriate outlet that is properly installed and grounded in accordance with all local codes and ordinances.

⚠ DANGER:

- Improper connection of the equipment grounding conductor can result in risk of electrical shock.
- Check with a qualified electrician or service provider if you are in doubt as to whether the equipment is properly grounded or installed on a dedicated line.
- Seek a qualified electrician to perform any modifications to the cord or plug. TRUE is not responsible for injuries or damages as a result of cord or plug modification.
- To reduce the risk of burns, fire, electric shock, or injury, it is imperative to connect each product to a properly grounded 110V or 220V electrical outlet. The voltage required for your unit is located on the serial number decal (usually on the front of the unit). Depending on where you live voltage requirements differ.
- Some TRUE products require a circuit rated 110V, 60 Hz, and 20 amps. In the United States, most residential homes have circuits rated 110V, 60 Hz, and 15 amps. If your unit requires a 20 amp outlet, contact an electrician to install a dedicated 20 amp circuit prior to use.
- **110 Volt**—This model is for use on a nominal 110V circuit and has a grounding plug that looks like the plug illustrated below. Make sure the product is connected to an outlet having the same configuration as the plug. No adapter should be used with this product.

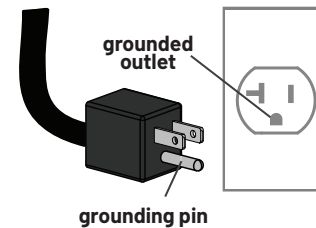

Power Information						
Model	Line Voltage (V)	Frequency (Hz)	Rated Current (Amps)	Number of Units per Circuit	Plug/Outlet*	Max Power Dissipation (Watt)
TC3-DA-35	110	50/60Hz	15	Dedicated 1	NEMA 5-20 	1230

*The plug configuration for the power adapter may vary by country.

SPACE REQUIREMENTS

TRUE recommends leaving a minimum of 24" (61cm) on each side of the equipment and a 79" (200cm) safety zone at the rear of the equipment.

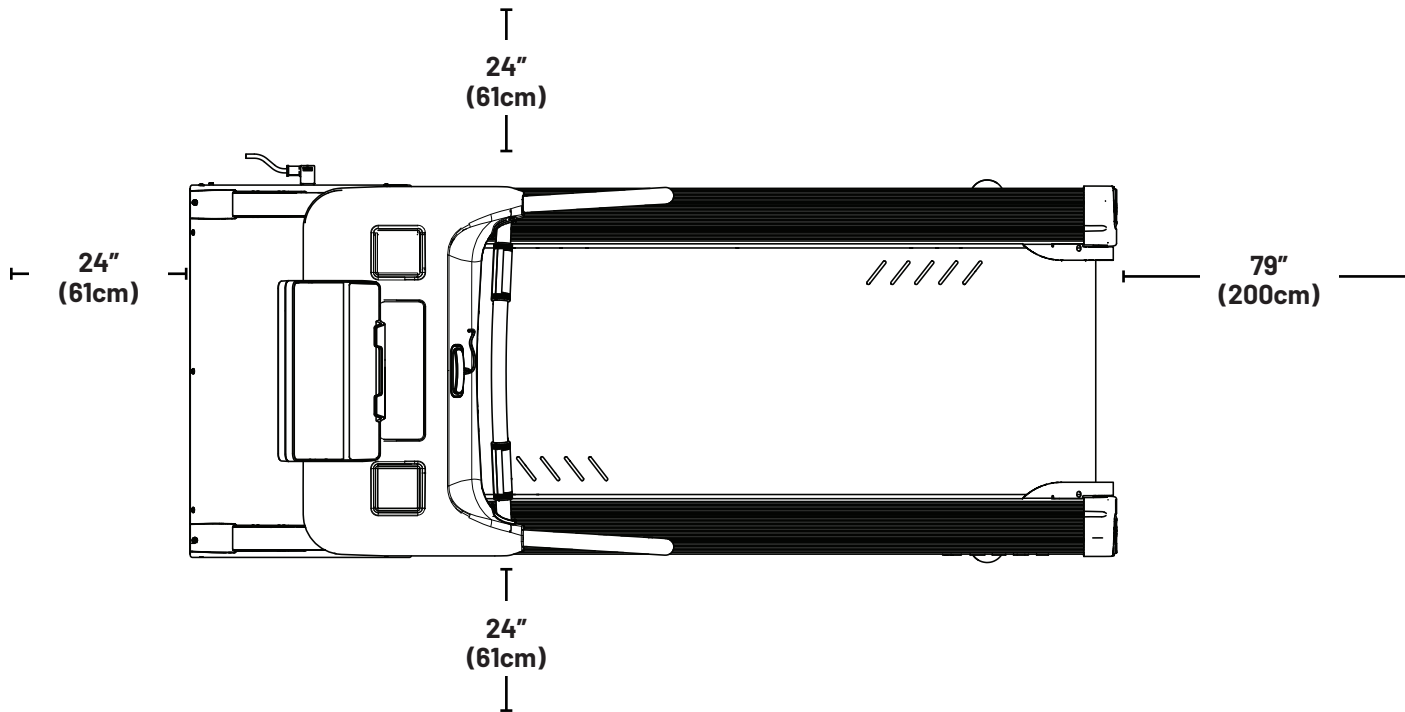

SPECIFICATIONS

- **DIMENSIONS (L X W X H)**
79" x 32" x 60.5" / 212.09cm x 81.2cm x 153.67cm
- **MACHINE WEIGHT**
349 lbs / 158.3 kg
- **MAXIMUM USER WEIGHT**
400 lbs / 181 kg

WARNING DECALS

⚠ WARNING: Replace warning labels that may be worn, damaged, or missing.

To replace any worn or missing decals contact TRUE product support (service@truefitness.com | 800.883.8783).

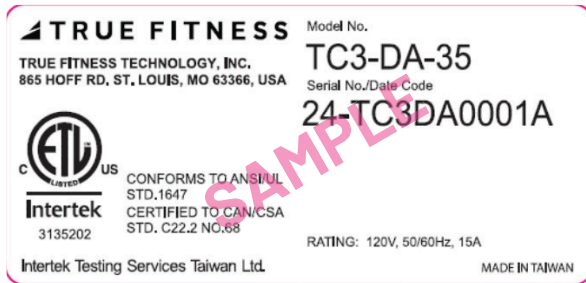

COMPLIANCES

This equipment complies with all applicable codes and regulations. For a complete list of compliances, please visit www.truefitness.com.

PROPER TRAINING POSITION AND TREADMILL SAFETY

Treadmill Entry

When first stepping on the treadmill, step onto the side rails (straddle covers) and hold the hand rails until both feet are fully on the belt.

Treadmill Use

Ensure you have good balance and your feet are stable before you start the treadmill.

Keep your gaze forward and avoid looking down or to your sides, this will help maintain good balance and prevent falls.

While using, ensure all hands, legs, and feet remain within the boundary box of the treadmill belt.

Treadmill Exit

When getting off the treadmill, wait until the belt comes to a full stop, then step on the side rails (straddle covers) and then onto the floor.



ASSEMBLY INSTRUCTIONS

 **NOTE:** Supplemental video available @TRUEFitnessservicevids: <https://www.youtube.com/playlist?list=PLr3lgy32UrupdGovHVj-zecgk9kvFdC2h>

PREASSEMBLY CHECKLIST

BASIC GUIDELINES FOR SETTING UP THE EQUIPMENT

After removing the equipment from the packaging, place the equipment on a clean, level surface. Make sure the electrical cord easily reaches a grounded three-pronged outlet.

⚠ DANGER: Do not use an extension cord or ungrounded outlet. The ground helps prevent electrical damage to your equipment and enhances your safety by helping to prevent shock. Check with a qualified electrician or serviceman if you are in doubt as to whether the equipment is properly grounded. Do not modify the plug provided with the unit if it will not fit the outlet. Have a proper outlet installed by a qualified electrician.

⚠ CAUTION:





**Use caution when assembling the equipment.
Unpacking and assembling of this product is a two person task.**







**Use caution when unpacking this product. Avoid damage to the product.
DO NOT use a box cutter. DO NOT slice into the packaging.**

VERIFY BOX CONTENTS

IMPORTANT! Please verify box contents. If you have questions, or if there are any missing parts, contact product support (service@truefitness.com | 800.883.8783).

TOOLS NEEDED FOR ASSEMBLY		INCLUDED IN BOX
5mm and 6mm Allen Wrench		NO
7/16" and 17mm Wrench		NO
8mm T-Handle Allen Wrench		NO

TOOLS NEEDED FOR ASSEMBLY		INCLUDED IN BOX
#2 Phillips Screwdriver		NO
Adjustable Wench		NO
Wire Cutters		NO

TOOLS NEEDED FOR ASSEMBLY		INCLUDED IN BOX
Level		NO

BOX CONTENTS

ITEM	DESCRIPTION	QTY
1	Base	1
2	Left Pedestal	1
3	Right Pedestal	1
4	Handrail Assembly	1
5	Upper Assembly	1
6	Lower Cover	1
7	Console Rear Cover	1
8	110V Power Cord	1
9	Hardware Pack	1
10	Assembly Instructions	1

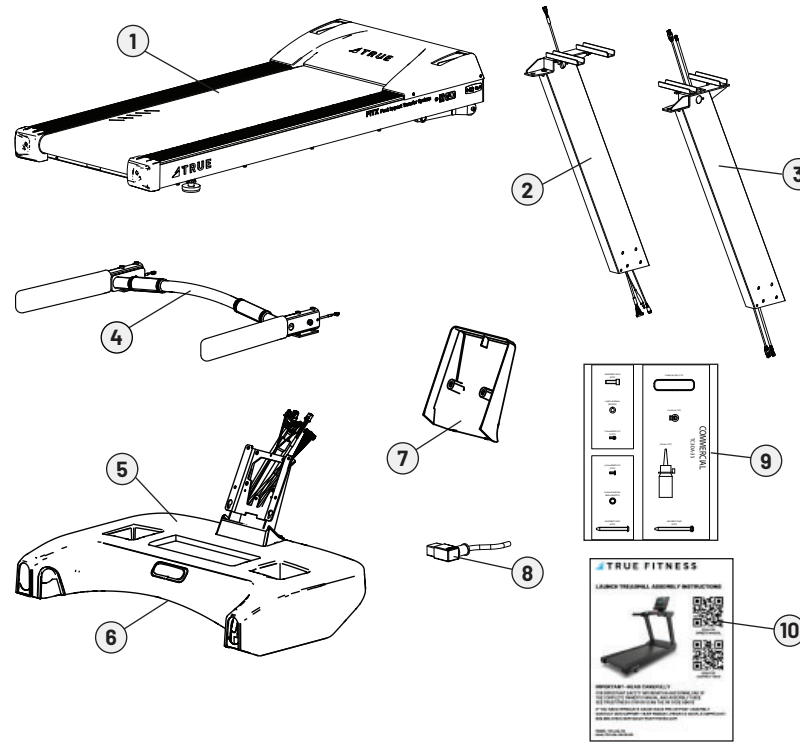

TC39170D HARDWARE PACK TC3-DA-35			
Item	Part	Description	Qty
1	PS0103	BHCS, M8 X 75MM	8
2	RT0011	WASHER, STAR, INTERNAL TOOTH, M8	8
3	PS0099	WASHER, SPRING M8	8
4	PS0100	SHCS, M8-1.25 X 25MM	8
5	TPS8123	SCREW, M8 X 90MM	4
6	TI0076	TRUSS PHILLIPS BOLT M4XP0.7X12	2
7	TCS0024	SCREW, SEMS, M4-0.7X12MM, NYLOK, BLK	11
8	ST1024	SAFETY KEY ASSEMBLY	1
9	TCS0028	CORD LOCK, SAFETY KEY	1
10	00349000	SILICONE LUBRICATION	1

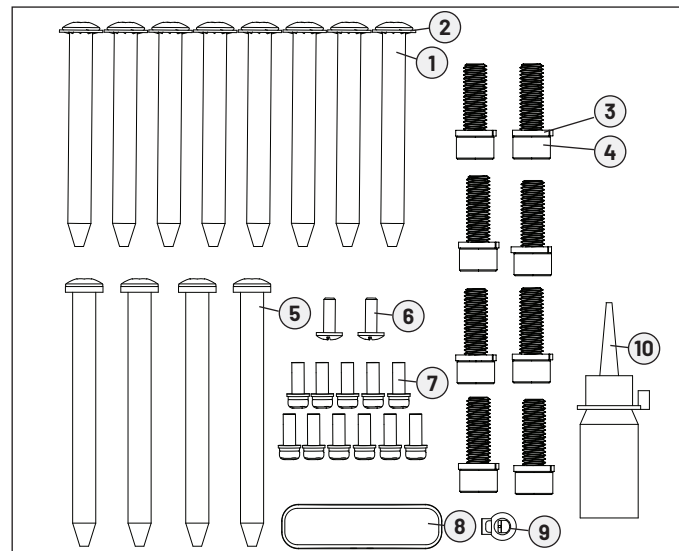

ASSEMBLY STEPS

Step 1—Remove Motor Cover and Motor Trim Covers

Tools Used in this Step	
#2 Phillips Screwdriver	

Parts Used in this Step			
Item	Part	Description	Qty
1	PS0035	SCREW, M5XP0.8X15MM SCA5-15	9
2	TPS9501	TRIM, MOTOR HOOD, LEFT, BLACK	1
3	TPS9502	TRIM, MOTOR HOOD, RIGHT, BLACK	1
4	TPS9500	COVER, MOTOR, BLACK	1

- A. Using a #2 Phillips screwdriver, remove and set aside the two screws securing the left and right motor trim covers.
- B. Remove and set aside the left and right motor trim covers.

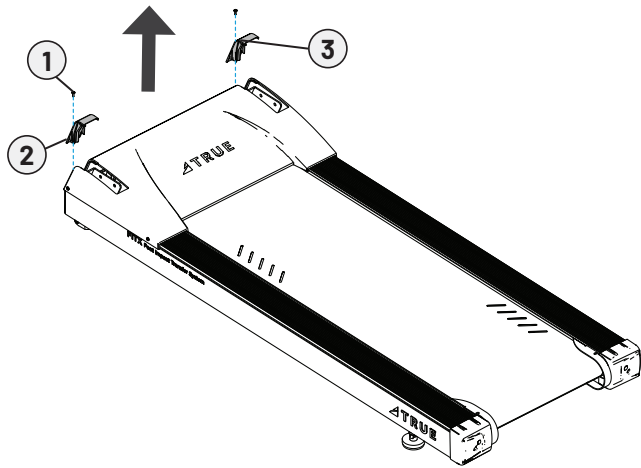

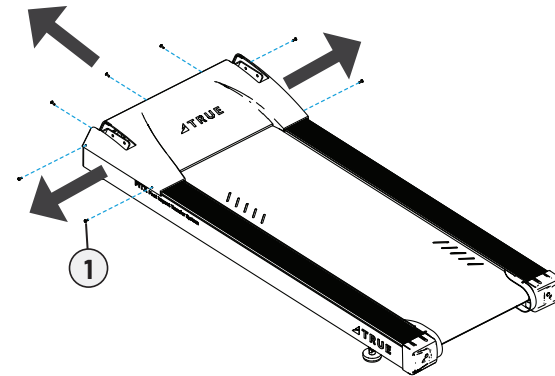

- C. Using a #2 Phillips screwdriver, remove and set aside the seven screws securing the motor cover.

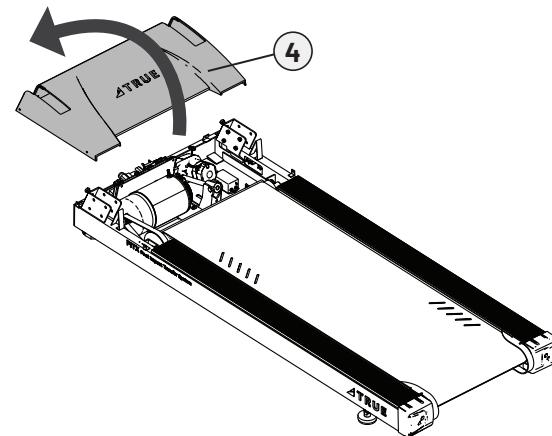

- D. Remove and set aside the motor cover.



Step 2—Attach Left and Right Pedestal Assemblies

Tools Used in this Step	
5mm Allen Wrench	
17mm Wrench	

Parts Used in this Step			
Item	Part	Description	Qty
1	TC39150D-35	ASSEMBLY, RIGHT PEDESTAL WITH CABLES, TC3 DC	1
2	TC39160D-35	ASSEMBLY, LEFT PEDESTAL WITH CABLES, TC3 DC	1
3	PS0103	BHCS, M8X75MM	8
4	RT0011	WASHER, STAR, INTERNAL TOOTH, M8	8

- Using a 17mm wrench, verify the two bolts on the lower front of the frame are backed out enough so the pedestals can slide into the frame.
- Slide the left and right pedestals into the frame.

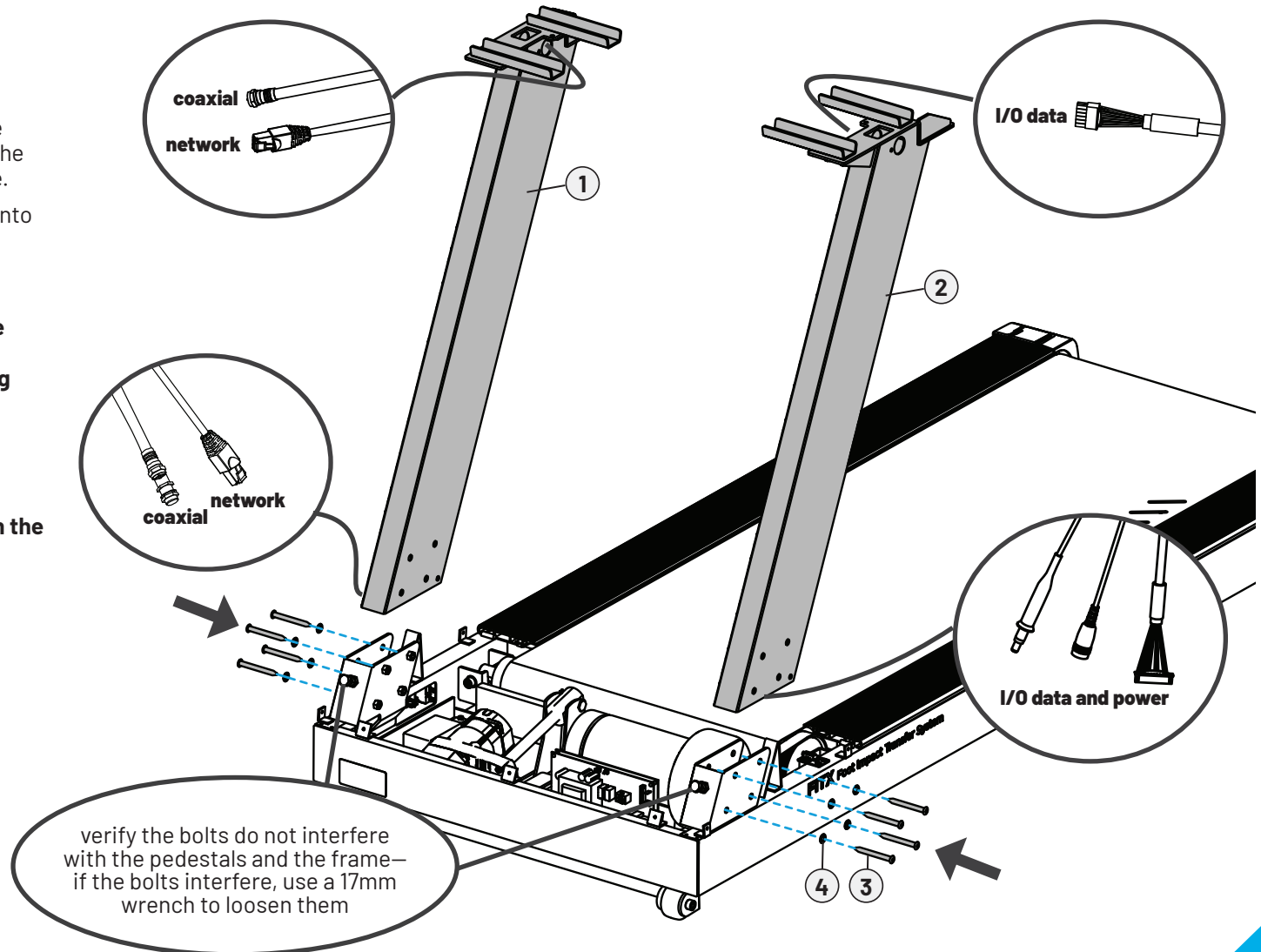

IMPORTANT! Carefully route the cables from the right and left pedestals toward the front of the frame. DO NOT pinch the cables. Keep all cables away from moving parts.

- Finger tighten or use a 5mm allen wrench to loosely attach the pedestals to the frame.
IMPORTANT! DO NOT fully tighten the hardware until step 6.



Step 3—Route and Connect Lower Cables—Install Optional Auxiliary Power Supply (if needed*)

***NOTE:** Touch screen and PVS consoles require the optional auxiliary power supply.

Tools Used in this Step	
7/16" Wrench	
Wire Cutters*	

Parts Used in this Step			
Item	Part	Description	Qty
1	00595500*	FUYANG POWER SUPPLY 12V 6AMP	1
2	TC6085_005*	ZIP TIE	2

Carefully make the following cable connections between the pedestals and the base:

- I/O Data Cable
- Power Cable Connections

NOTE: If an auxiliary power supply is not being used, connect the DC plug and DC jack and tuck out the way to avoid damage to the cables.

NOTE: If an auxiliary power supply is being used, make the DC power connection to the auxiliary power supply and then secure the cables and power supply with zip ties. See page 15 for more information.

- Network Cable
- Coaxial Cable

NOTE: To fully tighten the coaxial cable nut, use a 7/16" wrench.

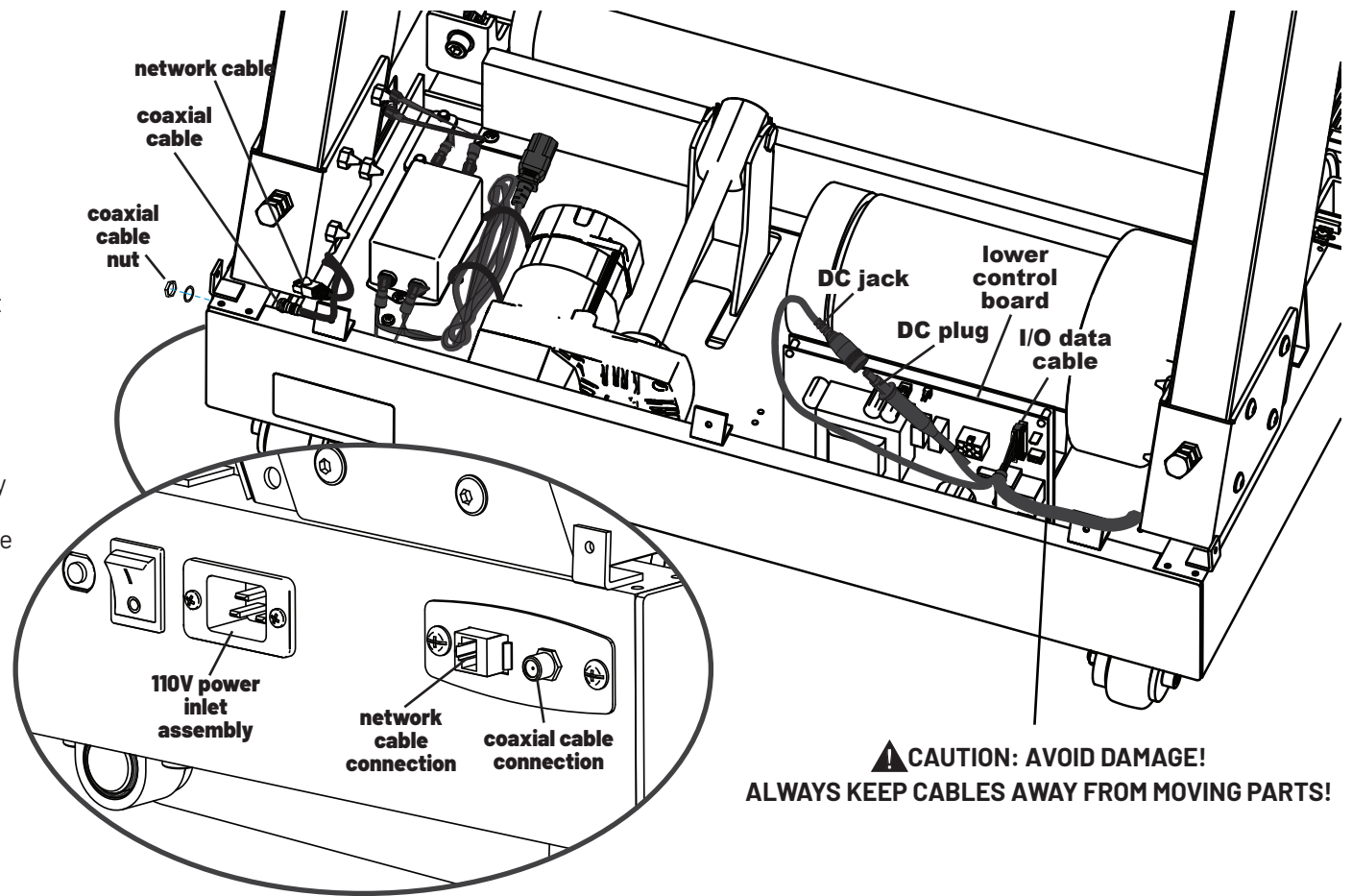

Step 3—Route and Connect Lower Cables—Install Optional Auxiliary Power Supply (if needed*) Continued

***NOTE:** Touch screen and PVS consoles require the optional auxiliary power supply.

If the optional auxiliary power supply is being used:

- A. Snip the cable ties securing the power cord in the base.
- B. Thread two new cable ties through the existing holes in the base.
- C. Place the auxiliary power supply in between the cable ties. Be sure the LED on the power supply is facing up.
- D. Route the AUXPS power cable from the left pedestal under the incline bracket.
- E. Connect the AUXPS power cable to the DC connector on the power supply.
- F. Secure the power supply with cable ties.
- G. Snip excess cable tie material.

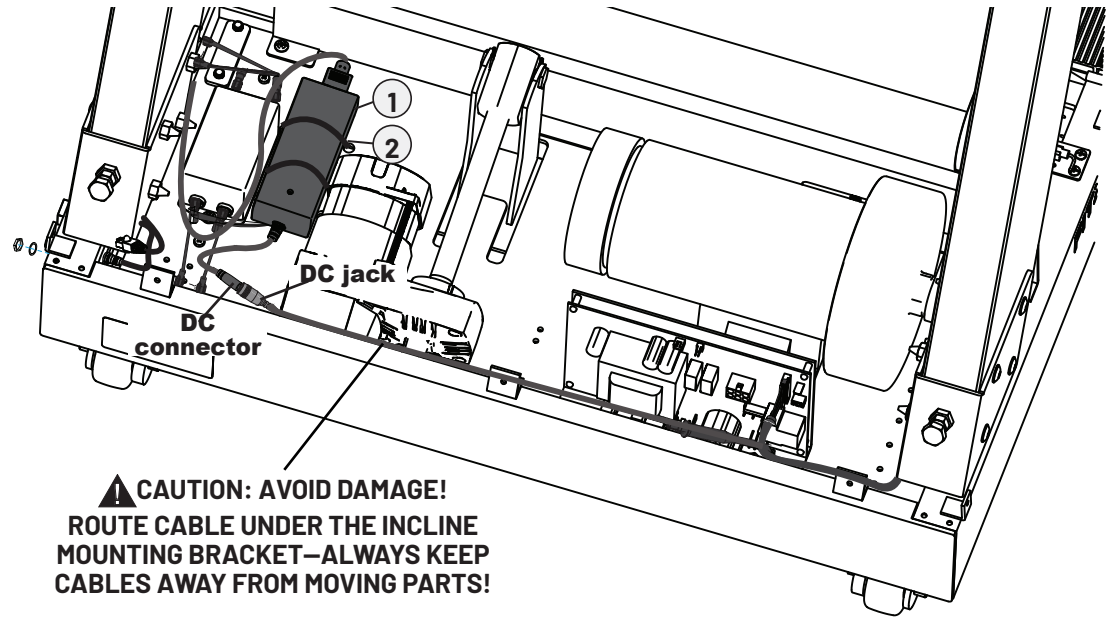

⚠ CAUTION: AVOID DAMAGE!
ROUTE CABLE UNDER THE INCLINE MOUNTING BRACKET—ALWAYS KEEP CABLES AWAY FROM MOVING PARTS!



Step 4—Attach Handrail Assembly

Tools Used in this Step	
5mm Allen Wrench	

- A. Align the holes of the handrail assembly with the holes on the pedestal assemblies.
- B. Finger tighten or use a 5mm allen wrench to loosely attach the handrail assembly to the pedestal assemblies.
- C. Using a 5mm allen wrench, evenly tighten the four hex screws, ensuring the holes remain aligned.

Parts Used in this Step			
Item	Part	Description	Qty
1	TC39200-35	ASSEMBLY, CONTACT HEART RATE AND HANDRAILS, TC3	1
2	TPS8123	SCREW, M8 X 90MM	4

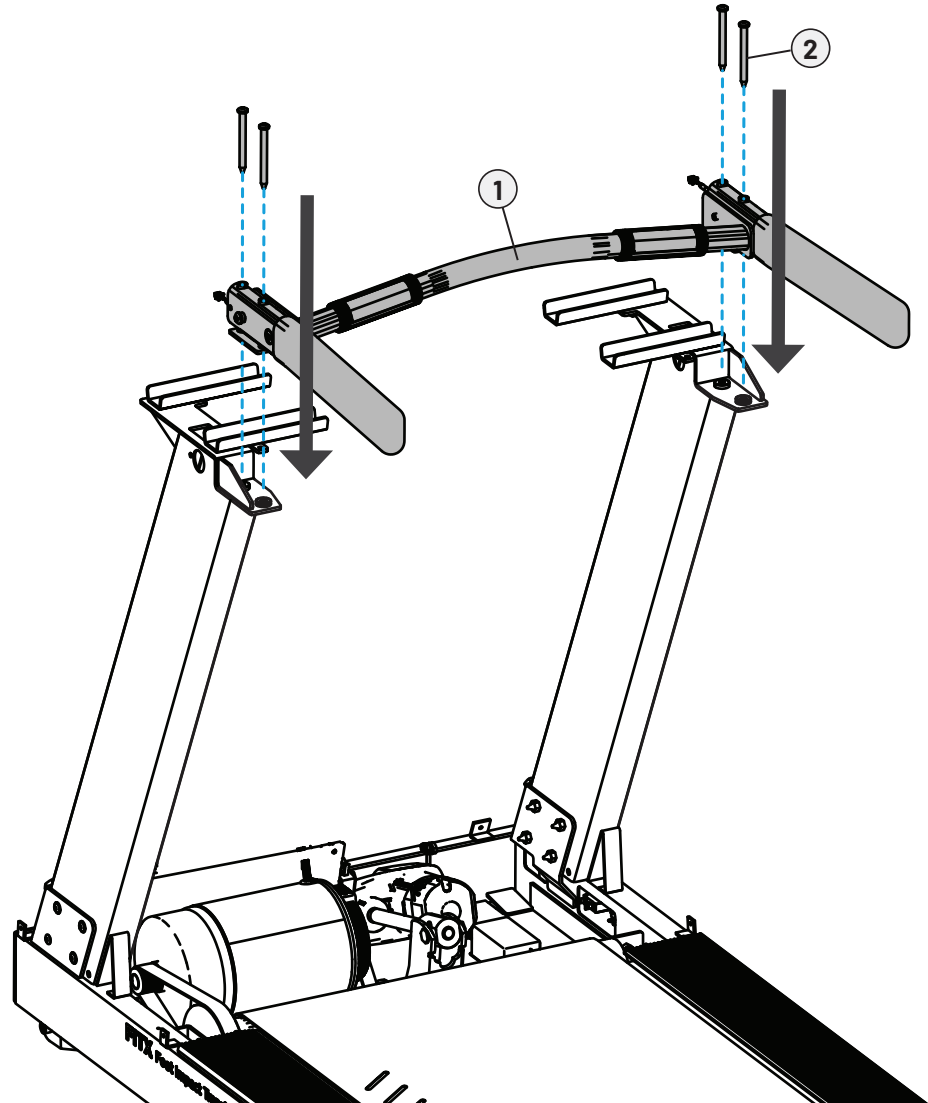

Step 5—Attach Upper Assembly and Connect Cables



Tools Used in this Step	
6mm Allen Wrench	

Parts Used in this Step			
Item	Part	Description	Qty
1	TC39100A-35	ASSEMBLY, UPPER, TC3 AC	1
2	PS0099	WASHER, SPRING M8	8
3	PS0100	SHCS, M8-1.25 X 25MM	8

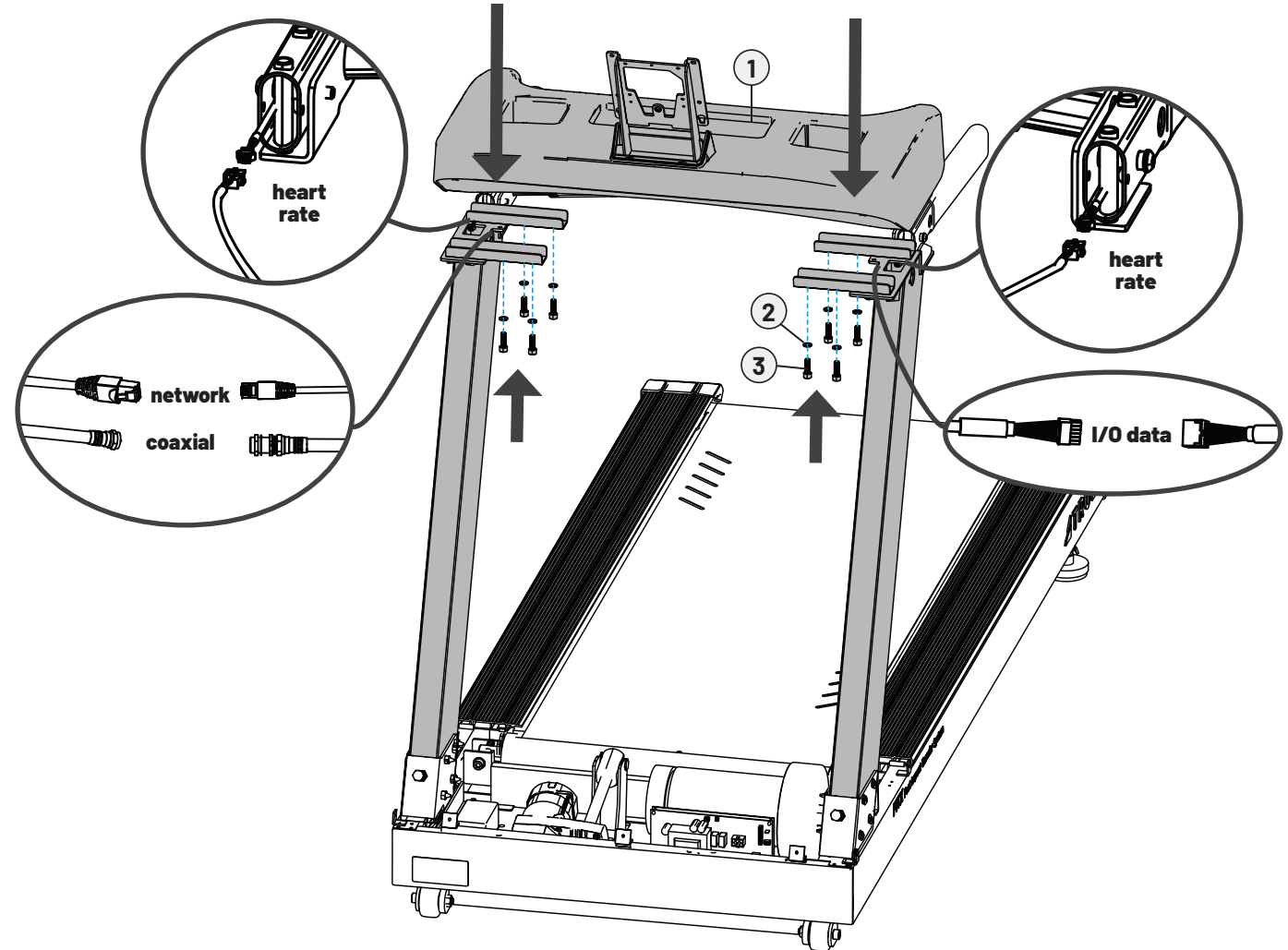
- Set aside the lower cover and then carefully set the upper assembly onto the left and right pedestals.
IMPORTANT! DO NOT pinch the cables.
- Connect the left and right heart rate cables between the upper assembly and handrail assembly.
- Connect the coaxial, network, and I/O data cables between the pedestals and upper assembly.
- Verify all cables have been securely connected and then carefully tuck excess cable length out of the way to avoid pinching.
- Finger tighten or use a 6mm allen wrench to loosely attach the upper assembly to the pedestal assemblies.
- Using a 6mm allen wrench, evenly tighten all eight hex screws and washers securing the upper assembly to the pedestal assemblies.



Step 6—Tighten Pedestals

Tools Used in this Step	
5mm Allen Wrench	
17mm Wrench	

- A. Using a 17mm wrench, verify the two bolts on the lower front of the frame are tightened against the pedestals.
- B. Using a 5mm allen wrench, fully tighten all eight hex screws and washers to secure the pedestals to the frame.

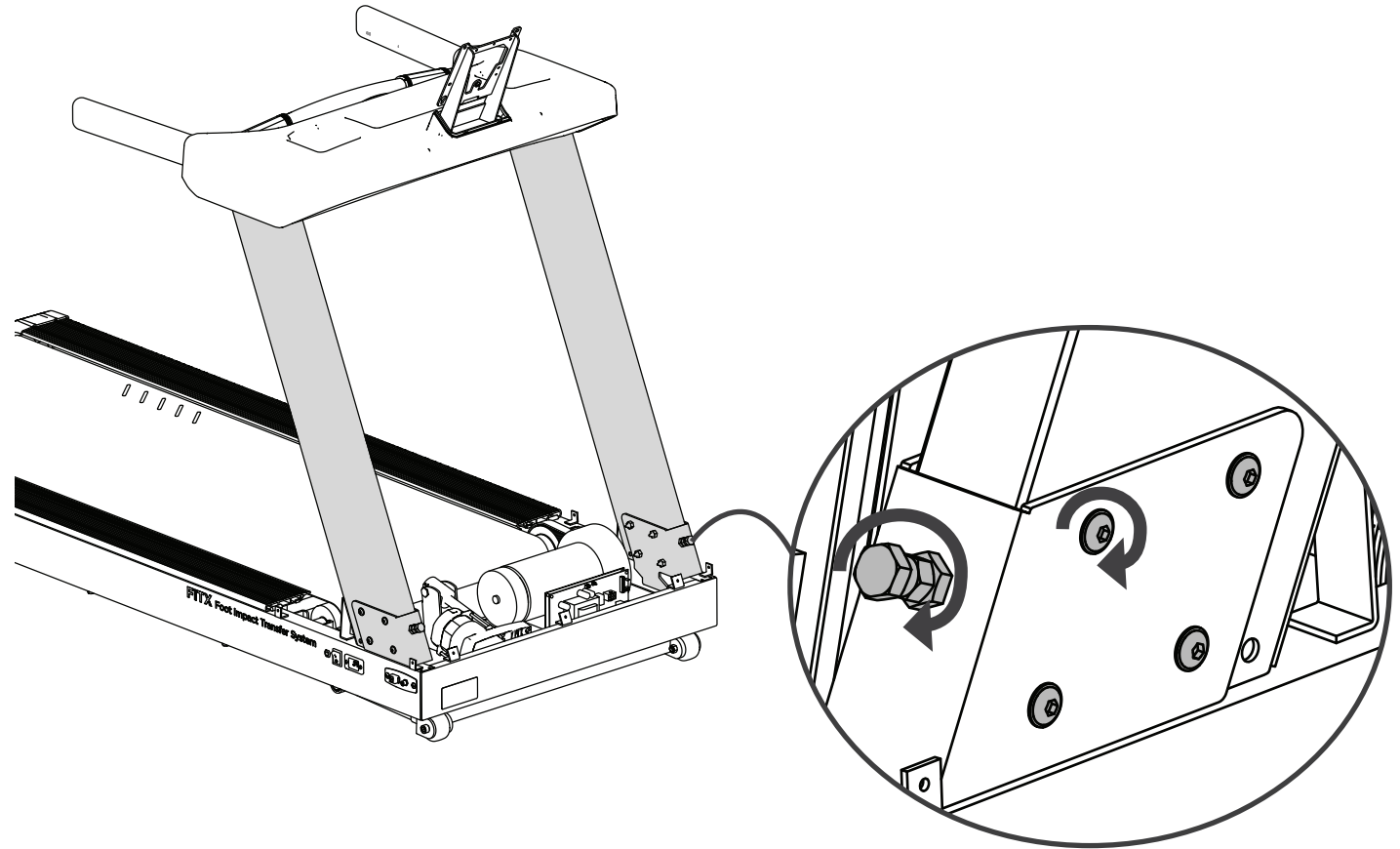

Step 7—Attach Console and Connect Power Cord

Tools Used in this Step	
#2 Phillips Screwdriver	

Parts Used in this Step			
Item	Part	Description	Qty
1	N/A	CONSOLE MAST ASSEMBLY	1
2	N/A	CONSOLE	1
3	TC39400	POWER CORD, 115V, C19, NEMA 5-15P, 10FT LONG	1

- A. If the console has three screws (00567700 // SCREW, M4-.7 X 12 PPHMS SEMS) preassembled, remove and set aside these screws. They are not used in this installation. Remove and set aside the top two screws (00567800 // SCREW, M5-.8X12 COMBO PHILLIPS/Common TRUSS HEAD - ACG BLACK) preassembled to the console. Slightly loosen the bottom two screws but leave them installed. All four screws will be used to secure the console to the mast in step C.

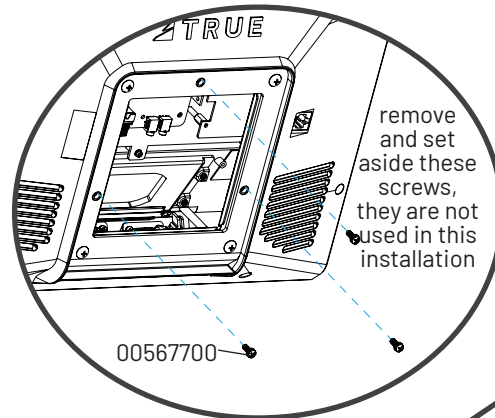

- B. Connect the cables: network, coaxial, heart rate, safety key, I/O data, power, and ground (use the screw on the console mast to attach the ground cable from the console).

NOTE: The LED console does not use the coaxial or network cables. Those cables can be tucked back down the console mast.

Ensure all cables are routed inside the console mast to avoid pinching the cables

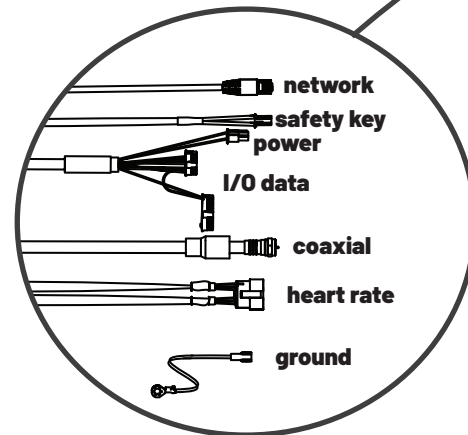

- C. Using a #2 Phillips screwdriver, secure the console to the console mast using the four screws (00567800).
- D. Insert the power cord into the power inlet.
- E. Power on the treadmill and verify the console powers up.

NOTE: Depending on the installation, PVS power may not be used.

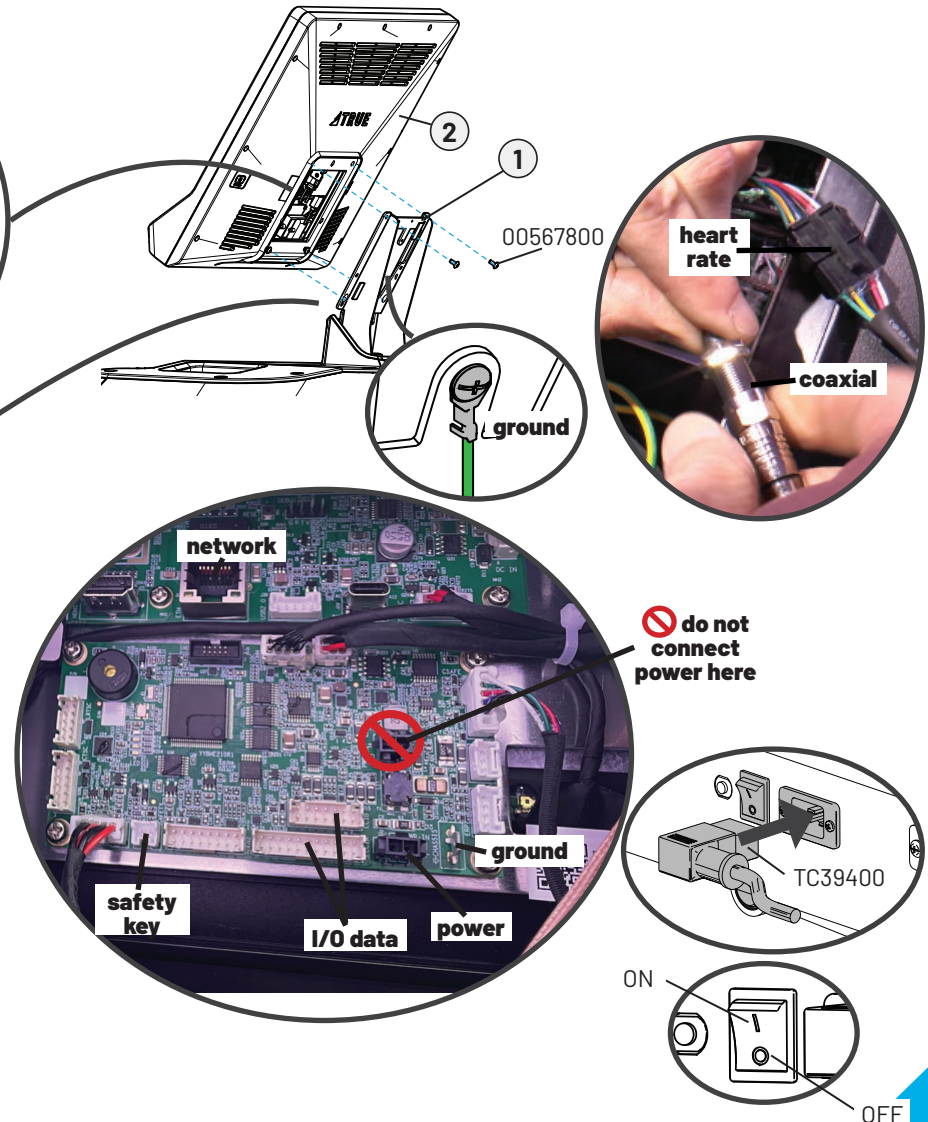

Step 8—Attach Console Rear Cover, Motor Cover, and Trim

Tools Used in this Step	
#2 Phillips Screwdriver	

Parts Used in this Step			
Item	Part	Description	Qty
1	PS0035	SCREW, M5XP0.8X15MM SCA5-15	9
2	TPS9501	TRIM, MOTOR HOOD, LEFT, BLACK	1
3	TPS9502	TRIM, MOTOR HOOD, RIGHT, BLACK	1
4	TPS9500	COVER, MOTOR, BLACK	1
5	TC30260	COVER, REAR CONSOLE COVER, TC3	1
6	TI0076	TRUSS PHILLIPS BOLT M4XP0.7X12	2

A. Using a #2 Phillips screwdriver, attach the rear console cover.

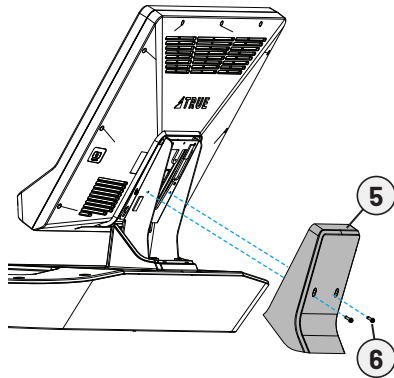

B. Reattach the motor cover.

C. Using a #2 Phillips screwdriver, reattach the seven screws securing the motor cover.

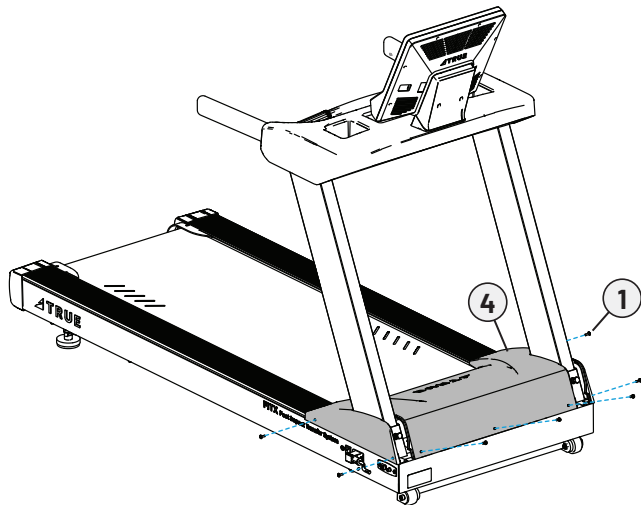

D. Reattach the left and right motor trim covers.

E. Using a #2 Phillips screwdriver, reattach the two screws securing the left and right motor trim covers.

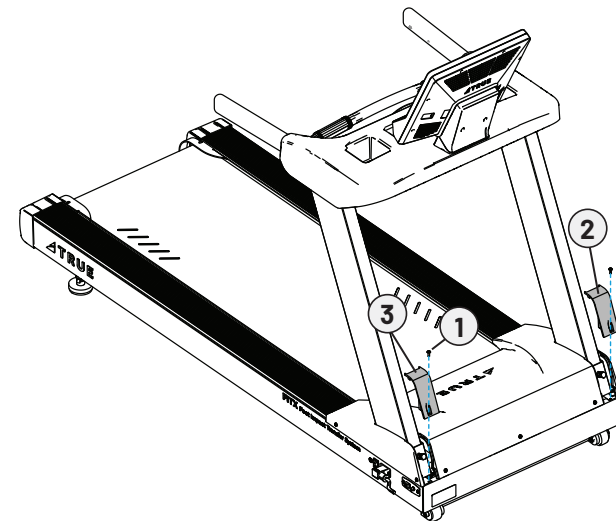

Step 9—Attach Upper Assembly Lower Cover

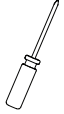
Tools Used in this Step	
#2 Phillips Screwdriver	

Parts Used in this Step			
Item	Part	Description	Qty
1	TSC0024	SCREW, SEMS, M4-0.7X12MM, NYLOK, BLK	11
2	TPS00230	COVER, LOWER TC3, BLACK	1

- A. Press the lower cover up against the bottom of the upper assembly.
IMPORTANT! DO NOT pinch the cables.
- B. Using a #2 Phillips screwdriver and 11 screws, secure the lower cover in place.

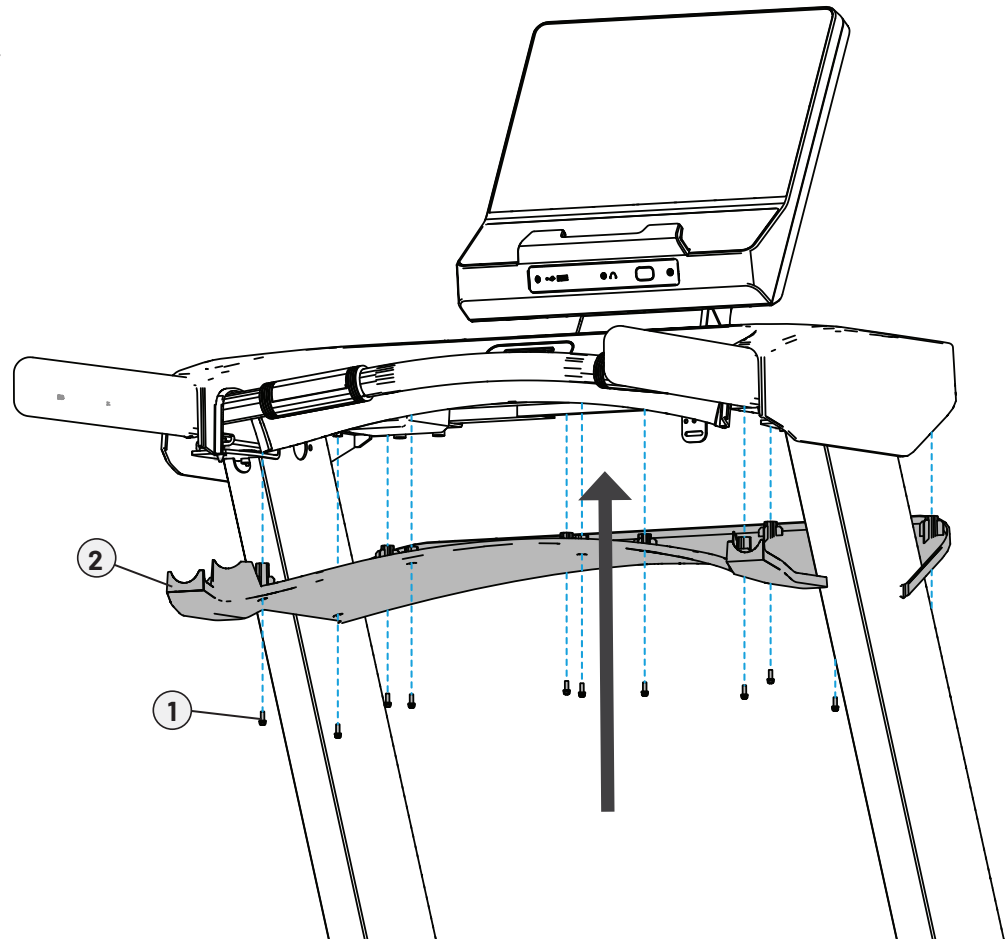

Step 10—Attach Safety Key

Parts Used in this Step			
Item	Part	Description	Qty
1	ST1024	SAFETY KEY ASSEMBLY	1
2	TCS0028	CORD LOCK, SAFETY KEY	1

- Insert the safety key cord through the holes on the metal tab.
- Attach the cord lock to the end of the safety key cord and pull the cord lock up behind the metal tab.
- Attach the safety key clip to the metal tab.
- If applicable, remove protective film from safety key attachment point on the console assembly.
- Attach the safety key to the console assembly.

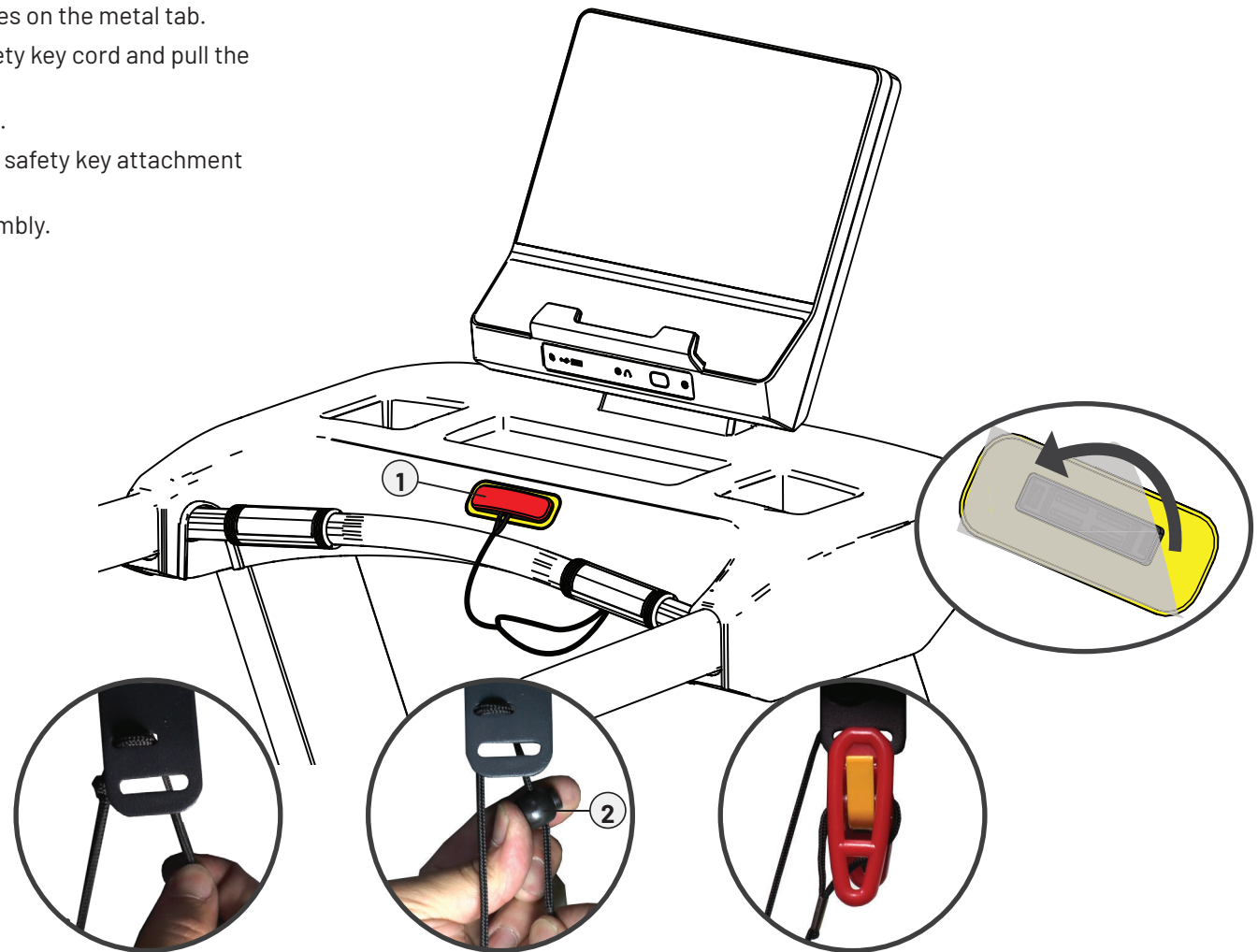

Step 11—Level the Treadmill

Once the machine has been moved to its designated location:

- A. Verify the treadmill is resting on the floor and not on any packaging materials.
- B. Using a level or estimating by sight, adjust both leveling feet until they contact the floor.

IMPORTANT! Do not adjust the leveling feet to such a height that they detach or unscrew from the machine.

- C. Verify both wing nuts on the leveling feet are securely tightened—wing nuts should be flush against the bottom of the frame.

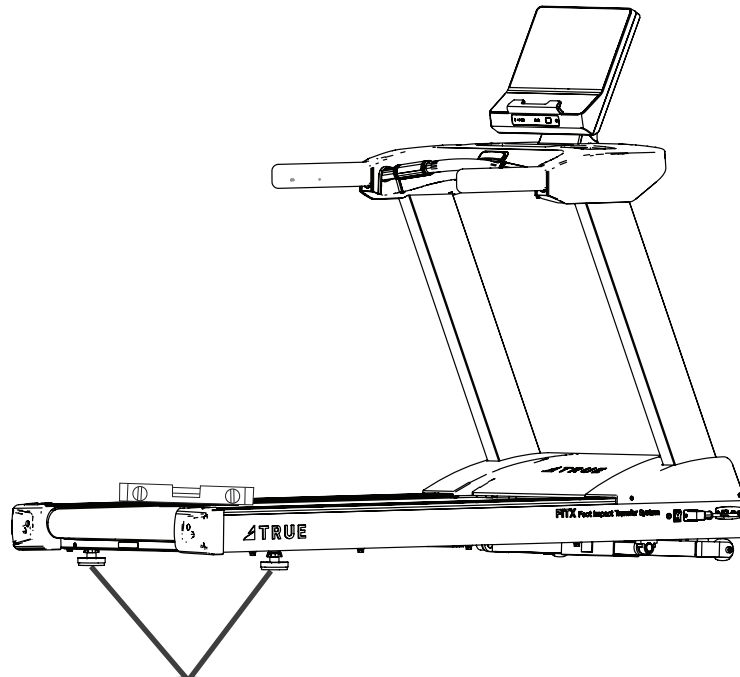

NOTE: You should be able to loosen and tighten the wing nuts by hand. If not, use an adjustable wrench.

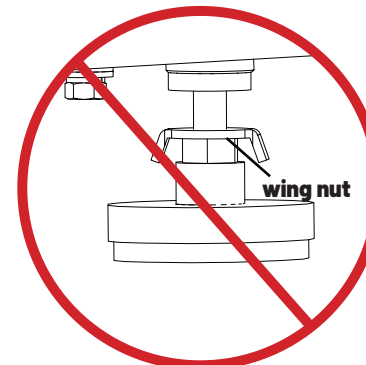
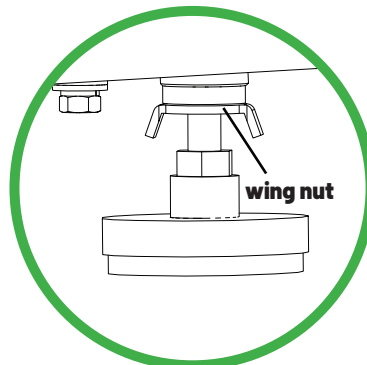
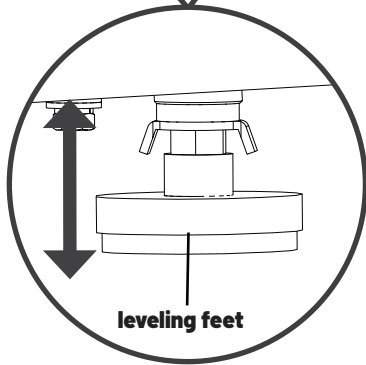

IMPORTANT STEP—DO NOT SKIP!

Step 12—Configure the Console with the Base and Run Calibration*

Please follow the instructions included with your console for important configuration and calibration steps.

Please contact product support right away if you run into issues setting up the machine:
800.883.8783 | service@truefitness.com | Monday–Friday 8:30am–5:00pm (CST)

***NOTE:** All new products require configuration. However, not all new products require calibration. Refer to the table below. If calibration is required, you must calibrate the machine.

PRODUCT CALIBRATION REQUIREMENTS		
REQUIRES CALIBRATION	DOES NOT REQUIRE CALIBRATION	
APEX TREADMILL	APEX ELLIPTICAL	GRAVITY CROSSTRAINER
GRAVITY TREADMILL PLUS	APEX CROSSTRAINER	GRAVITY RECUMBENT ELLIPTICAL
GRAVITY TREADMILL	APEX RECUMBENT BIKE	LAUNCH ELLIPTICAL
LAUNCH TREADMILL DC	APEX UPRIGHT BIKE	LAUNCH RECUMBENT BIKE
VAPOR STRYKER	APEX RECUMBENT ELLIPTICAL	LAUNCH UPRIGHT BIKE
VAPOR ALPINE RUNNER	GRAVITY ELLIPTICAL	VAPOR PALISADE
VAPOR SPECTRUM	GRAVITY RECUMBENT BIKE	VAPOR XT-ONE
	GRAVITY UPRIGHT BIKE	VAPOR LATERAL X

PRODUCT FEATURES

BASE OVERVIEW

A. Console Assembly

The console allows the user to set up a workout program and control the treadmill during a workout.

B. Contact Heart Rate Pads

Allows the user to check their heart rate without wearing a wireless chest strap.

IMPORTANT! For increased safety and accuracy this feature should only be used when the belt speed is below 4 mph.

C. Safety Key

A tethered safety device designed to attach to both the user and the treadmill console. Removal of the key from the console will stop belt motion to prevent injury in an emergency.

IMPORTANT! The safety key must be in place on the treadmill, and should be attached to the user's clothing. The treadmill will not operate if the safety key is not attached to the treadmill.

D. Belt

The moving surface of the treadmill on which the user walks or runs.

E. Straddle Covers

Stationary covers on either side of the belt, which allows the user to safely straddle the belt during startup or in the event of an emergency.

F. Belt Adjustment Bolts

An adjustment system that allows the users to adjust the belt tension as needed.

G. On/Off Switch

Allows users or faculty to turn the power on or off to the treadmill.

H. Power Cord

Delivers power from the wall outlet to the treadmill.

I. Leveling Feet

An adjustable system used to aid in the leveling the treadmill.



CONSOLE OVERVIEW

UNITE TOUCHSCREENS (16" SHOWN)

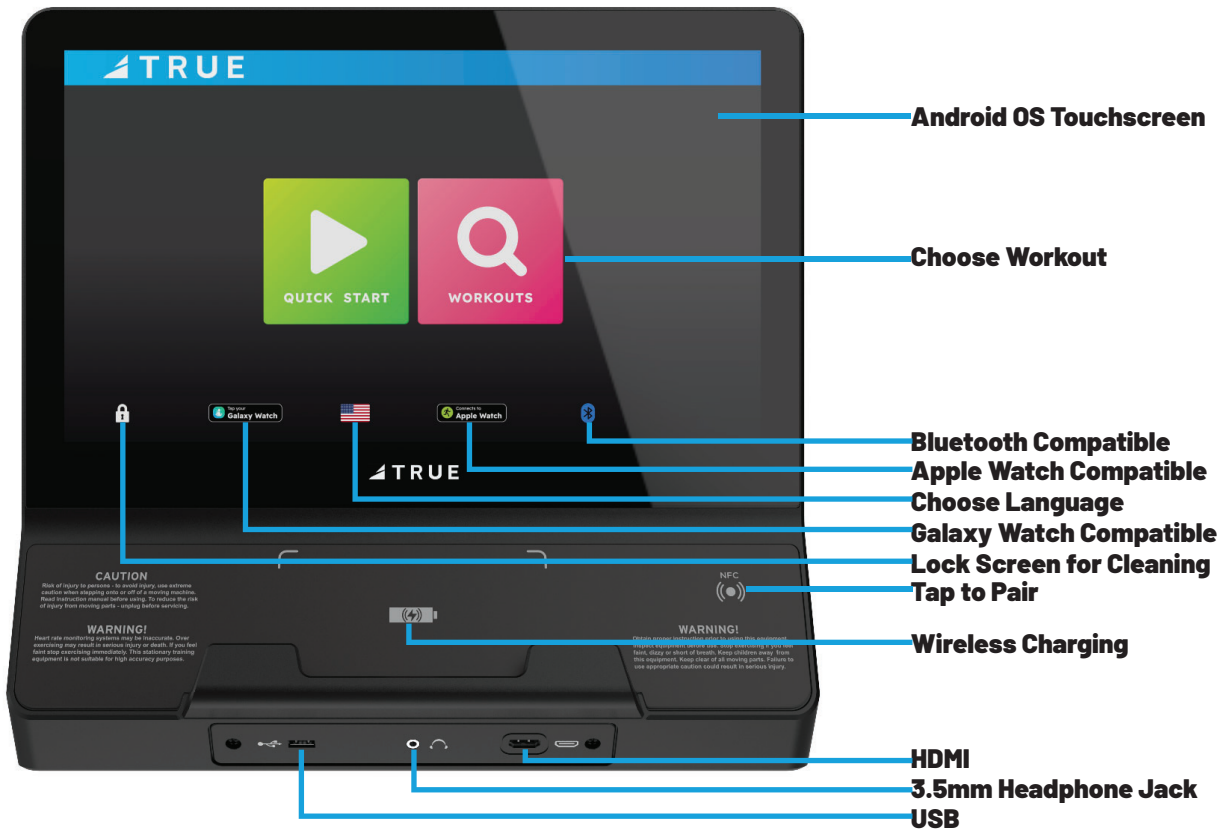

UNITE LED

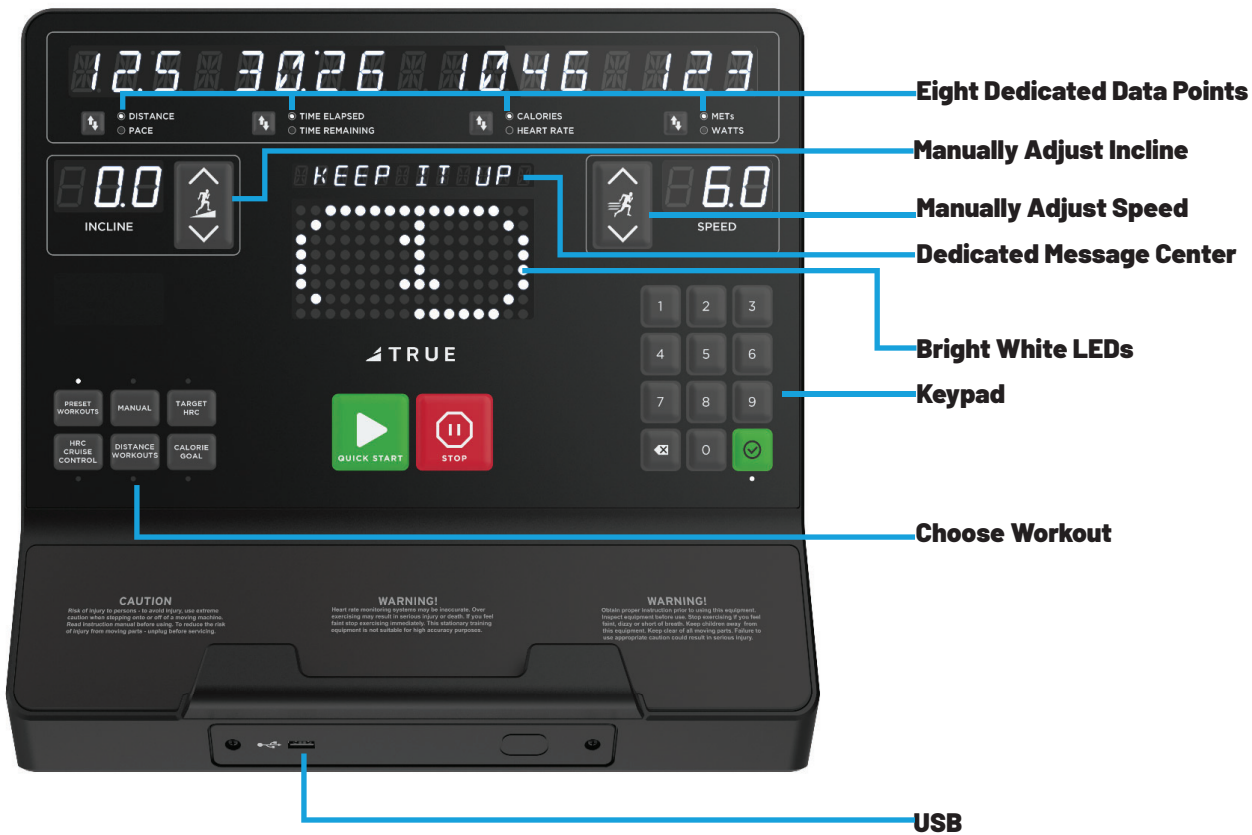

CARE AND MAINTENANCE

It is important to perform the minor maintenance tasks described in this section. Failure to maintain the treadmill as described here could void the TRUE Fitness Warranty. To reduce the risk of electrical shock, always unplug the unit from its power source before cleaning or performing any maintenance tasks.

INSPECTION

TRUE is not responsible for performing or scheduling regular maintenance or inspections. Users should inspect the treadmill daily. Check for worn, frayed or missing safety lanyards. Replace missing or worn safety lanyards immediately. Do not exercise on the treadmill without attaching the safety clip to your clothing. Look and listen for loose fasteners, unusual noises, worn or frayed power cords, and any other indications that the equipment may be in need of service. If any of these are noticed, obtain service. Do not attempt to use the treadmill until proper service has been performed or damaged parts have been replaced.

IMPORTANT!

If you determine that the treadmill needs service, make sure that the treadmill cannot be used inadvertently. Turn the unit off, and then unplug the power cord from its power source. Remove the magnetic safety key and safety clip and store it in a safe place. Make sure other users know that the treadmill needs service. To order parts or to contact a TRUE authorized service representative, please visit www.truefitness.com.

CLEANING THE EQUIPMENT

AFTER EACH USE

- Use GymWipes™ Antibacterial wipes or spray a solution of 30 parts water to 1 part mild detergent to dampen a soft cloth and wipe all exposed surfaces.
- Use a LCD/screen cleaner or spray a solution of 1 part 91% isopropyl alcohol and 1 part water to dampen a soft cloth and wipe the surface of the console. This helps remove fingerprints, dust, and dirt.

WEEKLY

- **Vacuum**—Use a vacuum to remove any dust or dirt that might have accumulated under or around the treadmill, any motor cover vents, and under the straddle covers. Clogged air vents can prevent adequate cooling to the drive motor, incline motor, and motor control board causing a shortened life.
- **Inspect Belt**—Check for proper running belt alignment and tension. If running belt adjustment is required, please see the following pages for how to adjust.

⚠ CAUTION:

Do not use any acidic cleaners. Doing so will weaken the paint or powder coatings and may void the TRUE Fitness Warranty. Never pour water or spray liquids on any part of the treadmill. Allow the treadmill to dry completely before using. Frequently vacuum the floor underneath the unit to prevent the accumulation of dust and dirt, which can affect the smooth operation of the unit. Use a soft nylon scrub brush to clean the running belt. Do not clean directly underneath the treadbelt. Most of the working mechanisms are protected inside the motor cover and base of the treadmill. However, for efficient operation, the treadmill relies on low friction. To keep the friction low, the unit's running belt, staging platforms, and internal mechanisms must be as clean as possible.

LEVELING THE MACHINE

⚠ CAUTION:

Prevent potential damage to the machine and injury to the user. This unit is equipped with adjustable rear leveling feet. Make sure that the running surface is level at all times. If the treadmill is placed on an uneven surface, adjusting the rear feet can help, but may not completely compensate for extremely uneven surfaces. Treadmills that are not level can cause misalignment of the belt, uneven belt wear, and possible injuries for the user.

Once the machine has been moved to its designated location:

- A. Using a level or estimating by sight, adjust both leveling feet until they contact the floor.

IMPORTANT! Do not adjust the leveling feet to such a height that they detach or unscrew from the machine.

- B. Verify both wing nuts are securely tightened (wing nuts should be flush against the bottom of the frame).

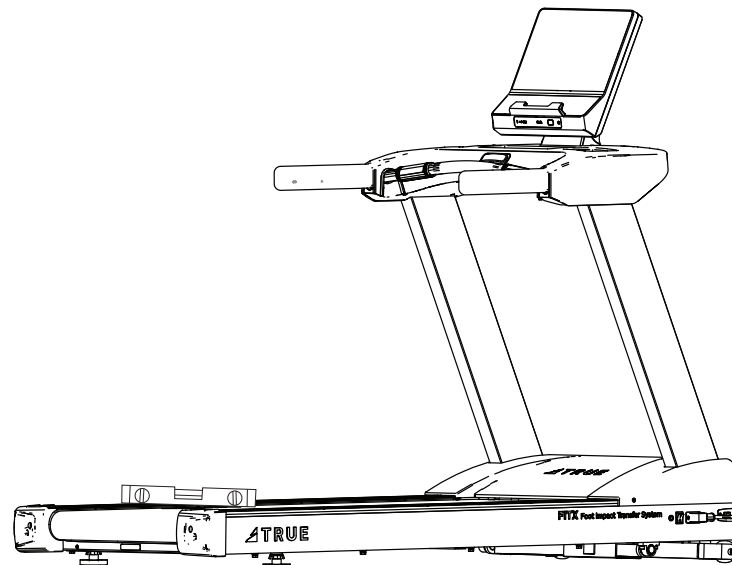

NOTE: You should be able to loosen and tighten the wing nuts by hand. If not, use an adjustable wrench.

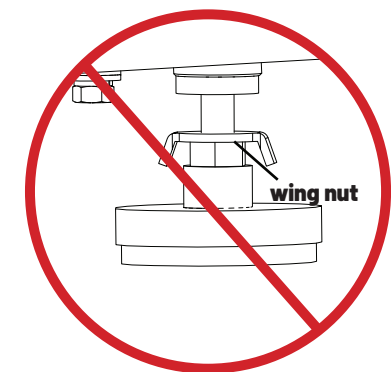
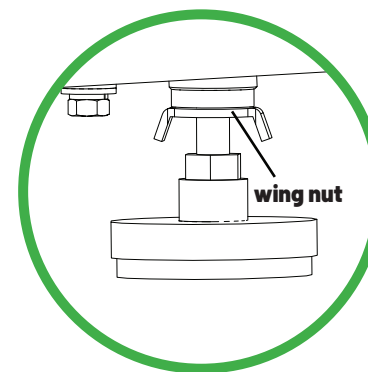
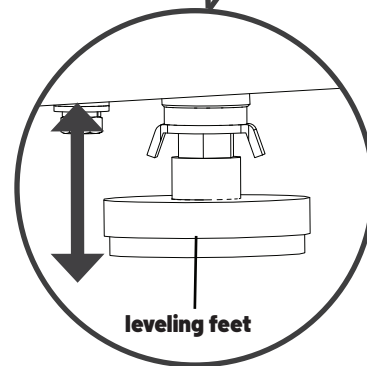

RUNNING BELT ALIGNMENT

Proper belt alignment allows the belt to remain centered and ensures smooth operation. Realigning the belt takes a few simple adjustments. If you are unsure about this procedure, contact TRUE product support (service@truefitness.com | 800.883.8783).

IMPORTANT! Damage to the running belt due to improper belt adjustments is not covered under warranty.

⚠ CAUTION:

- Verify the treadmill is level before attempting any belt adjustments. An unstable unit may cause belt misalignment.
- Special care must be taken when aligning the running belt. Turn off the treadmill while adjusting or working near the rear roller. Remove any loose clothing and tie back your hair. Be very careful to keep your fingers and any other object clear of the belt and rollers, especially in front of the roller and behind the deck. The treadmill will not stop immediately if an object becomes caught in the belt or rollers.
- If you hear any chafing or the running belt appears to be getting damaged, stop the running belt immediately by pressing **Stop**. Walk around to the rear of the unit and observe the belt for a few minutes. The belt should be centered on the running deck. If the belt drifts off center, you must make adjustments.
- For your safety, use the power switch to turn off the treadmill before making any adjustments. Do not adjust the running belt when someone is standing on the unit.
- Do not turn the adjusting bolt more than ¼ turn at a time. Over tightening the bolt can damage the treadmill and over stretch the belt.

IMPORTANT! Failure to align the belt may cause the belt to tear or fray, which may not be covered under the TRUE Warranty.

To stop the running belt:

- A. Press **Stop**.
- B. Turn the treadmill off.

If the running belt is too far to the right side:

- A. Locate the right side belt adjustment bolt in the rear end cap of the treadmill. (To determine left and right, stand at the rear of the treadmill and face the display.)
- B. On the right side of the machine, turn the adjustment bolt clockwise ¼ turn.
- C. Turn the treadmill on and start the belt at 3 mph (5 kph) keeping off the unit.
- D. Allow 2 minutes for the belt to self adjust.

Repeat these steps if additional adjustment is necessary.

If the running belt is too far to the left side:

- A. Locate the left side belt adjustment bolt in the rear end cap of the treadmill. (To determine left and right, stand at the rear of the treadmill and face the display.)
- B. On the left side of the machine, turn the adjustment bolt clockwise ¼ turn.
- C. Turn the treadmill on and start the belt at 3 mph (5 kph) keeping off the unit.
- D. Allow 2 minutes for the belt to self adjust.

Repeat these steps if additional adjustment is necessary.

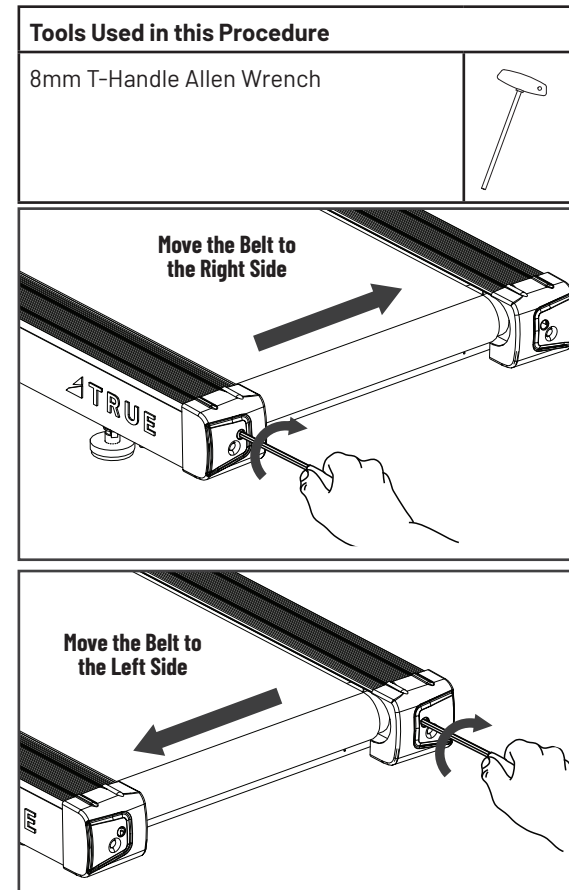

TENSIONING THE RUNNING BELT

If there is a slipping or jerking sensation when running on the treadmill, the running belt may require tightening. In most cases the belt has stretched from use. Tensioning the belt takes a few simple adjustments. If you are unsure about this procedure, contact product support (service@truefitness.com | 800.883.8783).

IMPORTANT! Damage to the running belt due to improper belt adjustments is not covered under warranty.

⚠ CAUTION:

- Verify the treadmill is level before attempting any belt adjustments. An unstable unit may cause belt misalignment.
- Special care must be taken when tensioning the running belt. Turn off the treadmill while adjusting or working near the rear roller. Remove any loose clothing and tie back your hair. Be very careful to keep your fingers and any other object clear of the belt and rollers, especially in front of the roller and behind the deck. The treadmill will not stop immediately if an object becomes caught in the belt or rollers.
- For your safety, use the power switch to turn off the treadmill before making any adjustments. Do not adjust the running belt when someone is standing on the unit.
- Do not turn the adjusting bolt more than $\frac{1}{4}$ turn at a time. Over tightening the bolt can damage the treadmill and over stretch the belt.
- If you tighten the belt and it still slips, the problem could actually be the drive belt, which is located under the motor cover and connects the motor to the front roller. If the drive belt is loose, it feels similar to the walking belt being loose. Tightening the drive belt should only be done by a trained service person, contact TRUE product support for assistance.



To tension the running belt:

- A. Press **Stop**.
 - B. Turn the treadmill off.
 - C. If the belt needs to be adjusted, locate the adjustment bolts in the rear end caps of the treadmill.
 - D. On each side of the machine, turn the adjustment bolts clockwise $\frac{1}{4}$ turn.
 - E. When both sides are measuring within range, turn the treadmill on and start the belt at 3 mph (5 kph) keeping off the unit.
 - F. Allow 2 minutes for the belt to self adjust.
 - G. Check to see if the belt is still slipping.
- Repeat these steps if additional tensioning is needed.

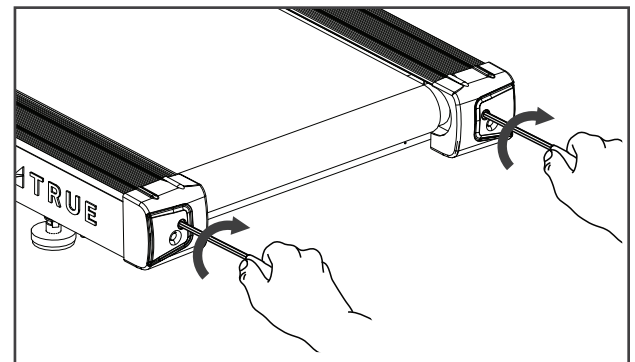
Tools Used in this Procedure	
8mm T-Handle Allen Wrench	



LUBRICATING THE TREADMILL

Items Used in this Procedure	
8mm T-Handle Allen Wrench	
00349000 TRUE Treadmill Lubrication	

For optimal performance, TRUE recommends lubricating the treadmill running belt and deck with TRUE lubricant every 200 miles.

To lubricate the deck and belt

1. Press the **Stop** key.
2. Turn the treadmill off.
3. Loosen the belt adjustment bolts in the rear end caps.
4. Lift the belt and apply the lubricant to the center of the deck.
5. Center the belt and retension.
See Tensioning the Running Belt for instructions.
6. Walk on the treadmill at 3 mph (5 kph) for approximately one minute to spread the lubricant evenly through the belt and deck.

Please contact your dealer or TRUE product support to obtain the proper lubrication.

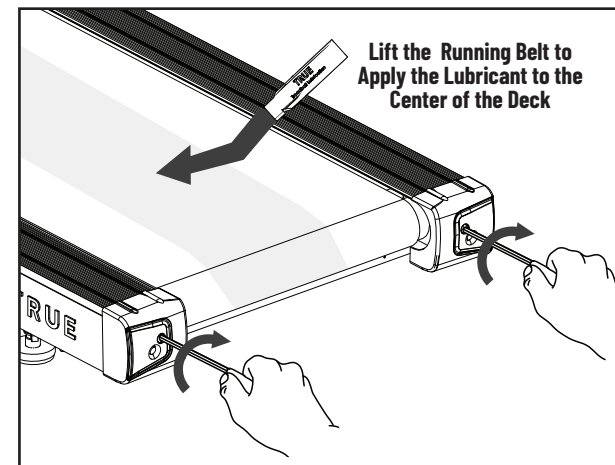

PREVENTATIVE MAINTENANCE

TRUE recommends that quarterly scheduled maintenance be performed by a qualified service technician. Please contact your dealer or visit www.truefitness.com to contact a local TRUE authorized service technician.

IMPORTANT! Use only TRUE Fitness certified service providers. Using non-authorized service providers could void the TRUE Warranty.

Frequency	Tasks
Daily	<ul style="list-style-type: none">• Look and listen for loose fasteners, unusual noises, worn or frayed cables, and any other indications that the equipment may be in need of service.• Use GymWipes™ Antibacterial wipes or spray a solution of 30 parts water to 1 part mild detergent to dampen a soft cloth and wipe all exposed surfaces.• Use a LCD/screen cleaner or spray a solution of 1 part 91% isopropyl alcohol and 1 part water to dampen a soft cloth and wipe the surface of the console. This helps remove fingerprints, dust, and dirt.
Weekly	<ul style="list-style-type: none">• Vacuum any dust or dirt that might have accumulated under or around the treadmill. Clogged air vents can prevent adequate cooling to the drive motor, incline motor, and motor control board causing a shortened life.• Check for proper slat belt tension.
Quarterly	<ul style="list-style-type: none">• Record time, distance, and hours from the console.• Check error log in console.• Remove shroud covers and vacuum any debris out of the speed sensor, control electronics and moving parts.• Move and vacuum underneath the machine.• Lubricate elevation pivot points including rear stabilizing feet and the lift motor screw.• Lubricate running belt and deck. Inspect all fasteners.• Inspect all electrical connections.• Inspect components for abnormal or premature wear.

LONG TERM STORAGE

When the treadmill is not in use for any length of time, turn it off. Make sure that the power cord is unplugged from the power source and is positioned so that it will not become damaged or interfere with people or other equipment.

CLEANING AND STORING THE CHEST STRAP

Clean the chest strap using a sponge or soft cloth dampened in mild soap and water. Dry the surface thoroughly with a clean towel. Store the chest strap in a place where it remains free of dust and dirt. Be sure to protect the chest strap from extreme temperatures. Do not store it in a place that may be exposed to temperatures below 32° F (0° C).

ADDITIONAL INFORMATION

TROUBLESHOOTING

This troubleshooting information is intended to assist in diagnostics only and is not all inclusive. Technical specifications, error codes, and programming are subject to change without notice. TRUE accepts no liability for any damage or loss suffered by persons whom rely wholly or in part on any description or statement contained within this manual. Please visit www.truefitness.com to obtain the most recent version of all manuals and contact TRUE product support (800-883-8783) for assistance with troubleshooting and diagnostics.

Malfunction	Possible Cause	Corrective Action
No Power	Unit turned off	Verify the On/Off switch is at the ON position
	Damaged power cord	Replace power cord
	Power cord not fully seated in socket	Inspect power connection at the unit and outlet
	No power at outlet	Using a voltmeter verify power at outlet
	Tripped circuit breaker	The location of the circuit breaker is next to the On/Off switch. Verify the circuit breaker is not open. If the breaker is open reset.
Unit resets or pauses randomly	Damaged power cord	Replace power cord
	Power cord not fully seated in socket	Inspect power connection at the unit and outlet
	Safety e-stop key not fully engaged	Re-engage the safety/e-stop key to the console
	Nucleus board may be damaged	Contact TRUE product support
	Insufficient power	Verify output voltage from 20A outlet with a voltmeter
	Error code is displayed on console	Contact TRUE product support
	Pinched or loose main communication cable	
	No User Present displayed on screen	User weight must be over 90lbs. Verify No User Present settings in console.
Walking belt hesitates or slips when stepping	Adjust belt tension	See Tensioning the Running Belt
Rubbing sound from treadmill when in operation	Foreign object may be stuck under walking belt	Inspect under the unit. Remove and object that may be under the unit.
	Foreign object may be stuck in motor compartment	
	Rollers may be damaged or misaligned	Contact TRUE product support
	Drive motor may be damaged	
	Drive belt may be misaligned	
	Slats may be loose or broken	
	Interference with anti-pinch bracket	
	Adjust belt tension	See Tensioning the Running Belt

Malfunction	Possible Cause	Corrective Action
Heart rate is displaying erratically or not displaying	Transmitter belt contacts are not making good contact with the skin	Re-adjust the transmitter belt so that it is in full contact with the skin
	Contacts on the transmitter belt are not moist	Moisten the contacts on the transmitter belt
	Transmitter belt is not within 3 feet (1 meter) of the heart rate receiver	Adjust your position on the belt so that you are within 3 feet (1 meter) of the console
	The battery inside the transmitter belt is depleted	Replace the transmitter belt with a compatible transmitter belt
	Another user wearing a compatible transmitter strap is within 3 foot (1 meter) of the unit	Move the units so that there is more space in-between units
	Environmental interference from high voltage power lines	Move the unit to another position within the room or move the cause of the interference until heart rate reading are stable. If the probable source of interference is plugged into the same outlet move the suspect source to another outlet.
	Environmental interference from computers	
	Environmental interference from motor driven appliances	
	Environmental interference from cell or cordless phone	
	Environmental interference from Wi-Fi router	
Contact Heart Rate not displaying	Machine needs to be restarted	Power cycle
	Cables are pinched or damaged	Contact TRUE product support
	Nucleus board may be damaged	Contact TRUE product support
	Heart Rate Grips may be damaged	Contact TRUE product support

WIRING DIAGRAM-110V

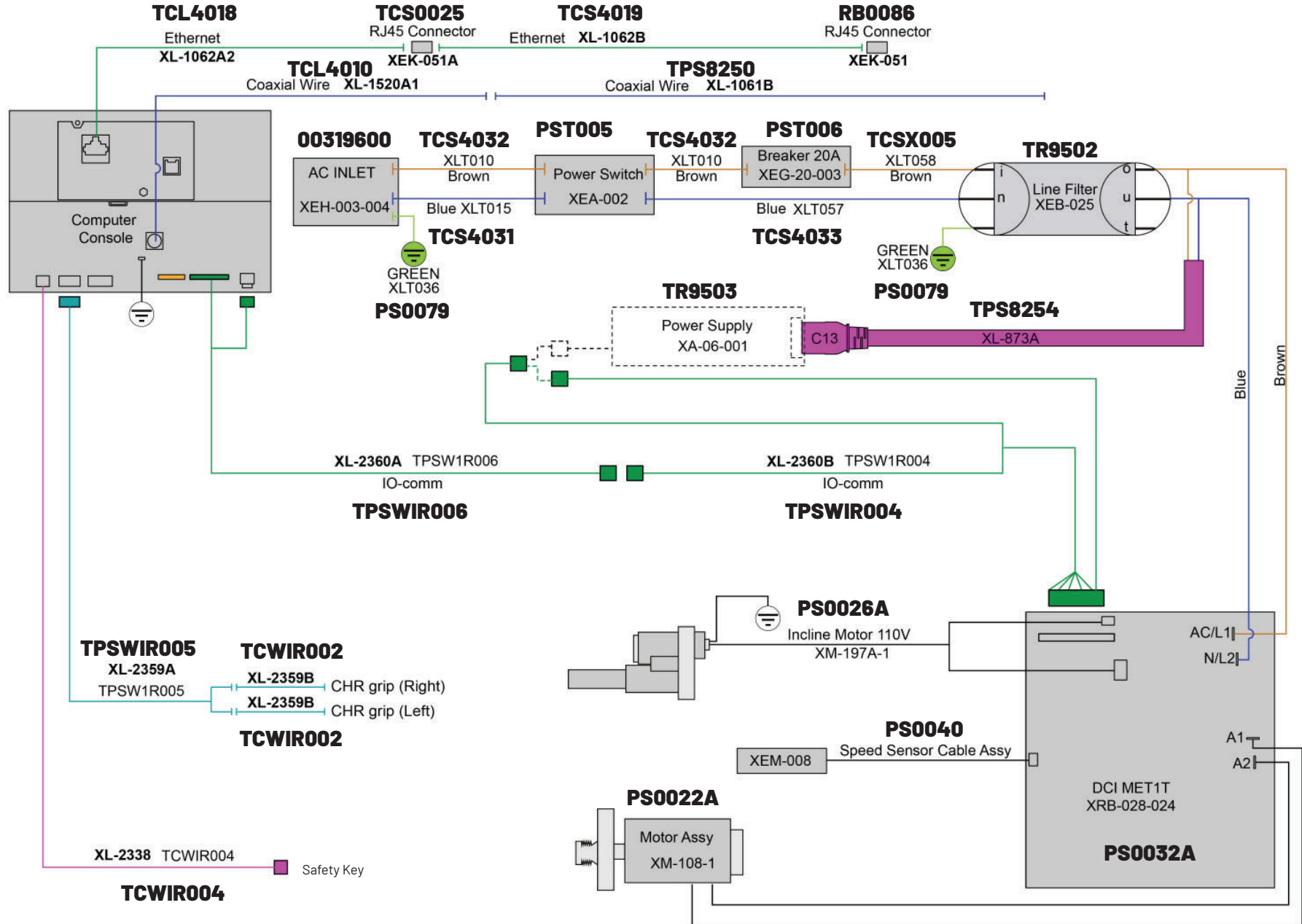

WARRANTY INFORMATION

COMMERCIAL WARRANTY

CARDIO				
WARRANTY ITEM	VAPOR, APEX	GRAVITY PLUS	GRAVITY	ADX, RO, SURGE
Frame*	7 Years	7 Years	7 Years	5 Years
Parts	3 Years	3 Years	3 Years	3 Years
Consoles	3 Years	3 Years	3 Years	2 Years
Labor**	2 Years	2 Years	1 Year	1 Year
Wear Items***	180 Days	180 Days	180 Days	90 Days

FLEXIBILITY	
WARRANTY ITEM	STRETCH
Parts	1 Year
Wear Items***	90 Days

STRENGTH	
WARRANTY ITEM	PALLADIUM, FUSE XL, FORCE, FITNESS LINE, ATLAS, XFT, XFW, MP, SM, FT, FS
Frame*	10 Years
Parts	5 Years
Cables and Linear Bearings	1 Year
Labor**	1 Year
Wear Items***	90 Days

Warranty does not cover damage or equipment failure resulting from or caused by improper assembly/installation, accident, misuse, abuse, unauthorized modification, or failure to provide reasonable and necessary maintenance.

*Frame is the serialized base of the unit and does not include paint or coatings.

**Labor is available for equipment located within United States and Canada.

***Wear Items include: batteries, covers, caps, badges, paint, pedal straps, toe clips, elliptical pedal inserts, foot pads, Coax/TV, HDMI, USB, mirroring or Ethernet connections, and safety key.

See Warranty Details for terms, conditions, and complete coverage details.

LIMITED-USE COMMERCIAL WARRANTY*

CARDIO				
WARRANTY ITEM	VAPOR, APEX	GRAVITY PLUS	GRAVITY	LAUNCH
Frame***	7 Years	7 Years	7 Years	7 Years
Parts	5 Years	5 Years	5 Years	3 Years
Consoles	3 Years	3 Years	3 Years	3 Years
Labor****	3 Years	3 Years	2 Years	1 Year
Wear Items*****	180 Days	180 Days	180 Days	180 Days

IN-HOME USE WARRANTY**

CARDIO				
WARRANTY ITEM	VAPOR, APEX	GRAVITY PLUS	GRAVITY	LAUNCH
Frame***	12 Years	12 Years	12 Years	7 Years
Parts	10 Years	7 Years	7 Years	5 Years
Consoles	3 Years	3 Years	3 Years	3 Years
Labor****	2 Years	1 Year	1 Year	1 Year
Wear Items*****	180 Days	180 Days	180 Days	180 Days

TRUE Fitness may offer alternative warranties to purchasers of commercial equipment for limited-use commercial* or in-home use.** This policy ensures that customers who use commercial equipment for limited-use commercial or in-home use may receive alternative warranty coverage, provided they meet the specified requirements. It's important to note that the specific terms and conditions of the alternative warranty, as well as the eligibility criteria, may vary depending on the product and TRUE's policies at the time of purchase. Customers should review the warranty terms and contact TRUE for precise details.

*To be eligible for the alternative limited-use commercial warranty, equipment use cannot exceed 6-hours use a day or be for use in a membership, dues paying, or institutional facility.

**To be eligible for the alternative in-home use warranty, equipment must be registered to a home address and cannot be used outside of the purchaser of the equipment and their immediate family.

Customers must provide TRUE with the following within 30 days of installation of the commercial-rated equipment:

- Purchase agreement.
- Proof of professional delivery and installation.
- TRUE will register the alternative warranty for the purchaser and implement it within 90 days of receiving the required documentation if such an alternative warranty is available for the specific product.

Warranty does not cover damage or equipment failure resulting from or caused by improper assembly/installation, accident, misuse, abuse, unauthorized modification, or failure to provide reasonable and necessary maintenance.

***Frame is the serialized base of the unit and does not include paint or coatings.

****Labor is available for equipment located within United States and Canada.

*****Wear Items include: batteries, covers, caps, badges, paint, pedal straps, toe clips, elliptical pedal inserts, foot pads, Coax/TV, HDMI, USB, mirroring or Ethernet connections, and safety key.

See Warranty Details for terms, conditions, and complete coverage details.

WARRANTY DETAILS

All TRUE Fitness products are distributed by TRUE and are warranted to the original registered product purchaser and the parts of the TRUE product (the "Product") listed below, under normal use and service, shall be free of manufacturing defects in workmanship and materials only for the specified period of time.

NOTE:

- Standard shipping is included with warranty part replacement.
- Shipping for warranty frame or replacement is included for the period of three years from the original date of purchase.

All Warranty Items are "LIMITED"

- This limited warranty does not cover damage or equipment failure resulting from or caused by improper assembly/installation, failure to follow instructions and warnings in owner's manual, accident, misuse, abuse, unauthorized modification, failure to provide reasonable and necessary maintenance, software version upgrades, compatibility with third party/aftermarket hardware, software, applications, or websites.
- TRUE's liability shall under no circumstances exceed the actual amount paid by you for the product, nor shall TRUE under any circumstances be liable for any consequential, incidental, special or punitive damages or losses, whether direct or indirect.
- Some states or countries do not allow the exclusion or limitation of incidental or consequential damages, so the above limitation or exclusion may not apply to you.
- TRUE will neither assume nor authorize any person to assure for us any other obligation or liability concerning the sale of this Product. Under no circumstances shall TRUE be liable under this warranty, or otherwise, of any damage to any person or property, including any lost profits or lost savings, for any special, indirect, secondary, incidental, or consequential damages arising out of the use of or inability to use this Product.
- This limited warranty, which is given expressly and in lieu of all other express warranties, constitutes the only warranty made by TRUE.
- The remedies described herein are your sole and exclusive remedies and TRUE's entire liability for any breach of this limited warranty.
- No one is authorized to change, modify, or extend the terms of this limited warranty.
- This limited warranty is in lieu of all other warranties of any kind either expressed or including but not limited to implied warranties of merchant.
- This limited warranty applies to the product only while the product remains in the possession of the original purchaser and is not transferable.
- This limited warranty becomes VALID ONLY if the Product is initially assembled/installed by a TRUE authorized dealer/technician (if anyone other than a TRUE authorized dealer/technician initially assembles and installs the Product, this limited warranty will be void unless the written authorization of TRUE is first obtained).
- This limited warranty can be processed only if the warranty registration form is completed on-line; or if the form provided with equipment is filled in, signed by the original purchaser, and mailed to TRUE within 30 days of purchaser's receipt of this Product.
- All serial numbers must be intact on the Product for this limited warranty to be valid.
- Installation or download of any 3rd party or after-market products will result in voided warranty. This includes, but is not limited to, electrical and mechanical parts, software, or applications.
- TRUE will ship to an authorized service provider any new or rebuilt replacement part or component, or at our option, replace or refund the Product.
- Replacement parts are warranted for the remaining portion of the original warranty period.
- Proof/receipts of necessary maintenance may be required within 30 days of requested warranty part or service.
- This limited warranty does not apply to the performance of the heart rate accuracy will not be warranted as performance varies, based on user's physiology, age, method of use, and other external factors.

WARRANTY REGISTRATION

Thank you for purchasing a TRUE product!

For warranty terms and conditions, see the complete owner's manual and assembly guide located at truefitness.com.

To validate your product warranty, you must register your product within 30 days of purchaser's receipt of this product.

To register your product:

- Go online to:
<https://truefitness.com/services-support/warranty-registration/>
OR
- Complete the information below and mail to:
TRUE Product Support
865 Hoff Road
St. Louis, MO 63366

PLEASE RETAIN THIS PORTION FOR YOUR RECORDS

BASE SERIAL NUMBER:

CONSOLE SERIAL NUMBER:

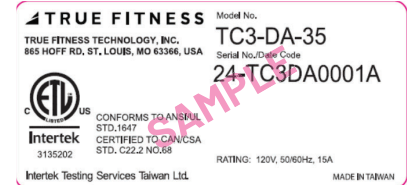

WARRANTY REGISTRATION

Base Serial Number

Console Serial Number

Purchase Date

Company (if applicable)

Customer Name (First and Last)

Email Address

Phone Number

Street Address

City

State

Postal Code

Country



CONTACT US
service@truefitness.com
800.883.8783

865 Hoff Road
St. Louis, MO 63366

[TRUEFITNESS.COM](https://www.truefitness.com)



MAN-TC3-DA-35 Owner's Manual and Assembly Guide REV02

© 2024 TRUE Fitness All Rights Reserved.