



FS-51 LEG PRESS ASSEMBLY MANUAL

Model: FS51
Rev: 030220

A MESSAGE TO OUR CUSTOMERS

Frank Trulaske began TRUE Fitness® over thirty-five year ago with the simple philosophy of delivering superior fitness products, service, and support. Today, TRUE is the global leader in premium fitness equipment for the commercial and residential markets. Our goal is to be the leader in technology, innovation, performance, safety and style. TRUE has received many awards for its product over the years and remains the benchmark for the industry. Fitness facilities and consumers invest in TRUE products for their durable commercial platforms used in all its products, both commercial and residential alike.

The proud manufacturing tradition of quality and the culture of innovation at TRUE have given rise to a full line of extraordinary cardio and strength equipment. As a result, people all over the world are benefiting from the TRUE experience. Innovation across the full product line has made TRUE successful and is a trademark of the TRUE heritage. TRUE's patented Heart Rate Control technology is just one of the remarkable ways we deliver simple and superior performance every user can enjoy, and most importantly, use to achieve personal health and fitness goals.

At the heart of our success is the relentless and systematic life testing of both our products and their components. We have dedicated employees who understand our philosophy is to deliver the best products in the world.

Our goal is to deliver the world's best premium equipment for our customers' health and fitness solutions.

TABLE OF CONTENTS

SAFETY.....	4
GENERAL CARE AND MAINTENANCE.....	7
DIMENSIONS AND WEIGHT.....	8
PREPARATION.....	9
BOX 1 CARTON CONTENTS.....	10
BOX 2 CARTON CONTENTS.....	11
INSTALLATION & ASSEMBLY	
STEP 1: INSTALL THE LEG PRESS CABLE.....	12
STEP 2: ASSEMBLE THE CONNECTING BRACE.....	13
STEP 3: ASSEMBLE THE UPRIGHT FRAME.....	14
STEP 4: INSTALL THE REAR BRACE.....	15
STEP 5: ASSEMBLE THE FOOT PLATE.....	16
STEP 6: ASSEMBLE THE HANDLES.....	17
STEP 7: ASSEMBLE THE SEAT PAD.....	18
STEP 8: ASSEMBLE THE BACK PAD.....	19
STEP 9: INSTALL THE UPRIGHT PULLEYS.....	20
STEP 10: ASSEMBLE THE WEIGHT STACK.....	21
STEP 11: INSTALL THE FRONT SHROUD.....	22
STEP 12: INSTALL THE REAR SHROUD.....	23
STEP 13: INSTALL THE TOP CAP.....	24
STEP 14: INSTALL THE BOLT CAPS.....	25
STEP 15: WEIGHT STACK LABEL.....	26
MACHINE LABELS.....	27
SERVICE.....	28
BOLTING THE MACHINE TO THE FLOOR.....	29
WARRANTY.....	30

SAFETY



FACILITY AND USER SAFETY PRECAUTIONS

1. Review and understand all of the warning labels affixed to this machine and on the facility safety sign.
2. Be certain that the machine operation is understood before it is used. Refer to the instructional Procedure Label affixed to the machine.
3. Make sure all users are properly trained on how to use this equipment. If this machine is being used in a commercial setting, end users may not have access to this Owners Manual. It is the responsibility of the facility to instruct users as to the proper usage of the equipment as well as making them aware of potential hazards.
4. Use each machine only for the intended exercise. Do not allow anyone to invent exercises not included on the Instructional Procedure Label or the Intended Use Label.
5. Do not modify the machine.
6. This equipment meets industry safety standards for stability when used for the intended exercise. Do not allow straps, resistance bands or other means to be attached to the framework of this machine to perform stretching or body weight exercises. This can result in machine instability and lead to serious crushing injuries.
7. Keep children away from this equipment. Adults should closely supervise use by teenagers.
8. It is recommended that users receive a thorough medical exam before commencing an exercise program. All medical issues should be reviewed to ensure that weight training will not aggravate pre-existing medical conditions.
9. If the machine appears damaged or inoperable, contact a facility staff member to place an "OUT OF ORDER, DO NOT USE" sign on the machine until it is repaired. Only use TRUE supplied replacement components to service this machine.
10. Instruct users not to wear loose or dangling clothes or have headphone wires hanging when using this equipment.
11. Do not attempt to free any jammed assemblies by yourself as this may cause injury.
12. On Plate Loaded and Free Weight machines:
 - 12a. Use of spotter(s). Instruct users to seek the advice of the facility staff as to the appropriate use of spotters when lifting. More than one spotter may be required depending upon the amount of weight being lifted.
 - 12b. Instruct users to load weight plates evenly and carefully (one side and then the other) to avoid tipping equipment and crushing injuries.
 - 12c. If the machine is equipped with safety stops or catches, inspect them and verify their proper operation before use and make sure they are securely in place before using or exiting the machine. Be certain members are instructed on how to operate and adjust all safety mechanisms.

- 12d. This equipment is designed for standard olympic size weight plates with a 50mm bore (1.9").
- 12e. Do not exceed the maximum weight capacity of the machine. Maximum plate size is 45 lbs. (25 kg.).
13. On Selectorized and Cable equipped machines:
- 13a. Do not allow users to perform any exercise by holding the end of the cable and/or the cable end fitting. Use only appropriate handles or attachments properly connected to the cable end.
- 13b. Do not high-pin or double-pin the weight stack. Do not allow the machine to be used if the top plate or weight stack is pinned in a raised position. Use an assistant and carefully return the machine to the proper position with the cap plate resting on the top weight. Inspect the entire length of the cable to ensure that it is properly seated in all of the pulley grooves.
- 13c. Do not allow the use of weight plates or dumbbells to be used as a means to add additional weight to the weight stacks. Use only the TRUE adder weight system specifically designed for the machine.



INSTALLATION SAFETY PRECAUTIONS

1. Read this Installation Manual entirely before assembling this equipment.
2. Verify that there is adequate space surrounding this piece of equipment for safe access and operation. Installation must meet ADA requirements for accessibility.
3. Install this piece of equipment on a solid level surface that does not deviate more than 1/8" over a 10' distance (or as defined and required by local building and architectural codes.
4. TRUE strongly recommends that all equipment be anchored to the floor to prevent movement and increase stability.
 - Due to the wide variation of flooring on which the unit can be installed, contact a qualified contractor to determine an appropriate fastening system for your floor.
 - Use 3/8" diameter hardware (10 mm) to anchor the machine. Anchors should have a minimum pull out force of 220 lbs (110 kgs) for each position.
 - When attaching the machine to the floor, if there is a gap between the machine foot and the floor, do not use the anchor to remove the gap as this can cause the machine frame to deform. Instead, place a shim between the bottom of the foot and the floor, then tighten the anchor.
 - Anchoring holes are provided on the feet of the frame. All anchoring locations must be used when anchoring the equipment to the floor.
5. DO NOT install any fitness equipment near a pool, hot tub or other damp locations. Corrosion caused by installation in these locations can lead to premature failure of components.
6. Be sure all hardware is tight before using this machine.

SAFETY



MAINTENANCE SAFETY PRECAUTIONS

1. Refer to Maintenance Schedule label on the machine as well as this manual for when to perform maintenance.
2. Check the function of your machine DAILY by verifying the following:
 - Inspect cables and end fittings for any signs of wear. Replace if worn, frayed or damaged with original TRUE replacement components.
 - Verify that all adjustments are possible and carried out with ease. Make sure that each adjustment pin inserts completely into each position without binding.
 - Verify that safety catches and stops are in proper working order and engaged.
 - Verify that the exercise is performed smoothly, free of noise and/or binding.
 - If equipped with a weight stack, verify that the proper weight selector pin is in place.
3. Check the function of your machine WEEKLY by verifying the following:
 - **Nuts, Bolts, and Fasteners:** Check tightness weekly. If any hardware has become loose, retighten and/or use Loctite™ Threadlocker 242.
 - **Frames and Lifting Arms:** Inspect weekly for integrity and function. Replace any component at first signs of wear. Use only TRUE supplied components.
4. Replace any warning label at first sign of wear. Labels and the Facility Safety Sign may be obtained from TRUE free of charge.

BOLT LENGTH MEASURING GUIDE

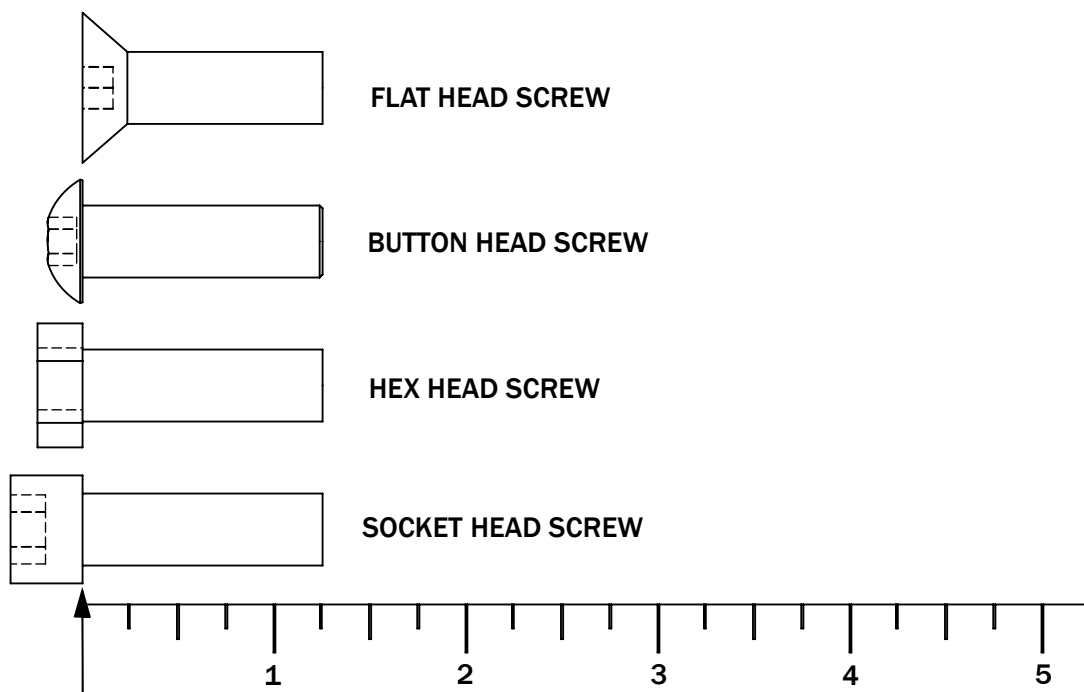

GENERAL CARE AND MAINTENANCE



IMPORTANT

Preventative maintenance is crucial to maintaining the function and safety of this equipment. Your facility must establish written guidelines for preventative maintenance and keep written or online records of the maintenance performed on these products. As a minimum, the items presented in the SAFETY section of this document and the items that follow here, should be included in your maintenance program.

1. **Cables:** Inspect end fittings daily for wear. Inspect the entire length of the cable weekly. Replace cables at the first sign of wear and on an annual basis. If the cable tension has been adjusted, be certain that the cable nut is tight.
2. **Nuts, Bolts, and Fasteners:** Check tightness weekly. If any hardware has become loose, retighten and/or use Loctite™ brand Threadlocker 242. Be sure all hardware is tight before using the machine.
3. **Safety Catches:** Inspect catches, stop rods and their associated fasteners weekly. Tighten any loose hardware and replace any components at first signs of wear.
4. **Frames:** Wipe all machines down with a damp cloth and dry completely each day. This includes painted parts, chrome parts and upholstered pads.
5. **Painted and chrome plated parts:** Use Simple Green or similar cleaner for light dirt and grime. Use Turtle Wax Polishing Compound or a good car polish to remove heavier dirt and grease as well as for polishing. DO NOT use solvents, lacquer thinner, acetone or finger nail polish remover. For scuffs and marks that are not removed by the above methods use a soft scrub cleanser. Make sure all parts are dry upon completion.
6. **Weight stack enclosures (shrouds):** Wipe down with a damp cloth as needed.
7. **Exercise instruction labels:** Clean with soap and water as needed.
8. **Guide rods:** Wipe all dirt and dust from the guide rods before applying a light application of Tri-Flow™ or other teflon spray lubricant. Spray the Tri-Flow™ on a rag and then wipe the guide rods with the rag. DO NOT use oil lubricants such as WD-40. Caution: Tri-Flow™ will stain carpet and clothing.
9. **Bronze bushings:** Check monthly for signs of wear and replace as needed.
10. **Linear Bearing Shafts:** Wipe any accumulation of dust or other contaminants from the shafts on a weekly basis. Apply a thin layer of a Teflon® (PTFE) grease on a weekly basis. TRUE recommends Magnalube® brand.
11. **When replacing any component, use only TRUE supplied parts.**
12. **Please refer to the General Maintenance Manual (part number: AM-GMM) for other important safety and maintenance information.**
13. **Be sure all hardware is tight before using the machine.**

Retain these instructions for future reference.

If you have any questions, do not hesitate to contact your TRUE dealer or TRUE Fitness Corp. at (800) 883-8783 or service@truefitness.com.

DIMENSIONS AND WEIGHT

“IN USE” MACHINE DIMENSIONS

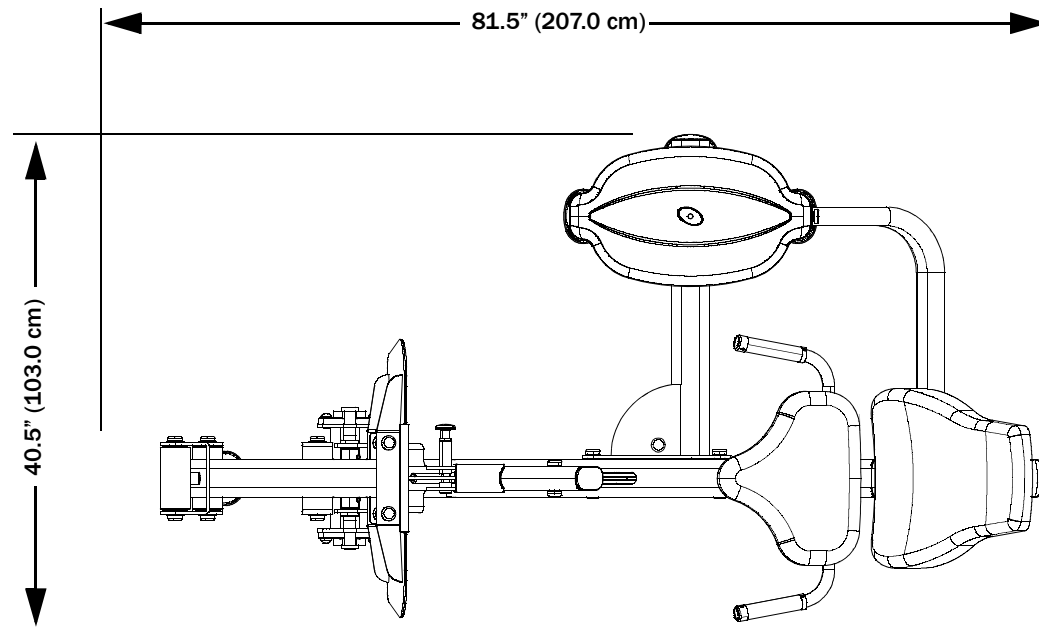

Machine Height: 64.4" (163.5 cm)

Maximum user weight: 300 lbs. (136 KG)

MACHINE WEIGHT AND FLOOR LOADING

WEIGHT STACK CONFIGURATION	MACHINE WEIGHT	APPROXIMATE FLOOR LOADING
170 lbs.	469 LBS [213 KG]	56 LBS/FT ² [273 KG/M ²]
250 lbs.	549 LBS [249 KG]	66 LBS/FT ² [319 KG/M ²]

PREPARATION

REQUIRED TOOLS:



Ratchet Wrench and Sockets:
9/16"

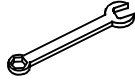

Wrenches: 1/2", 9/16", 3/4".
(or an adjustable crescent wrench).

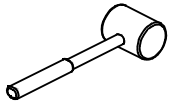

Rubber Mallet



Allen wrenches: (included with the machine)

Hardware Measurement Guide:

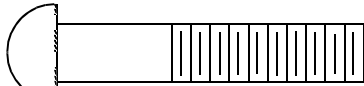

BHCS - BUTTON HEAD CAP SCREW

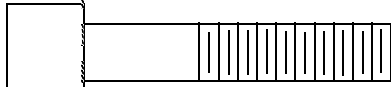

SHCS - SOCKET HEAD CAP SCREW

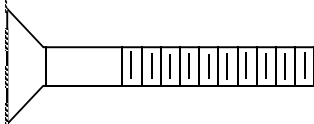

FHCS - FLAT HEAD CAP SCREW

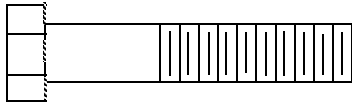

HHCS - HEX HEAD CAP SCREW

MEASURE BOLT
FROM HERE

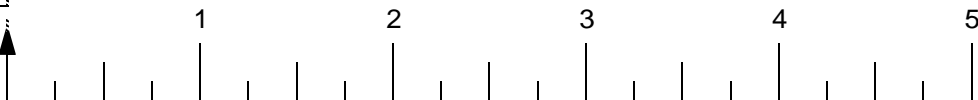

Weight Plate Cartons:

Weight plates are packaged (4) per box. You should have (4) boxes of weights. This will give you a total of 16 weight plates.

The weight plates are available in two different sizes, 10 lbs. and 15 lbs. The 10 lbs. plates are used for the 170 lbs weight stack, the 15 lbs. plates are used on the 250 lbs. weight stack. Make sure you know which size weight stack is to be installed on this machine.

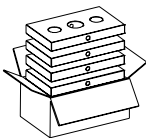

10 LB. Weight Plate Box
Part Number: B1602
Comprised of
(4) x 10 lb. Weight Plates

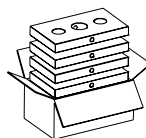
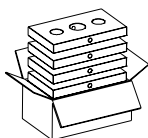

15 LB. Weight Plate Box
Part Number: B1603
Comprised of
(4) x 15lb. Weight Plates

OR

FS-51 Box 1 CARTON CONTENTS

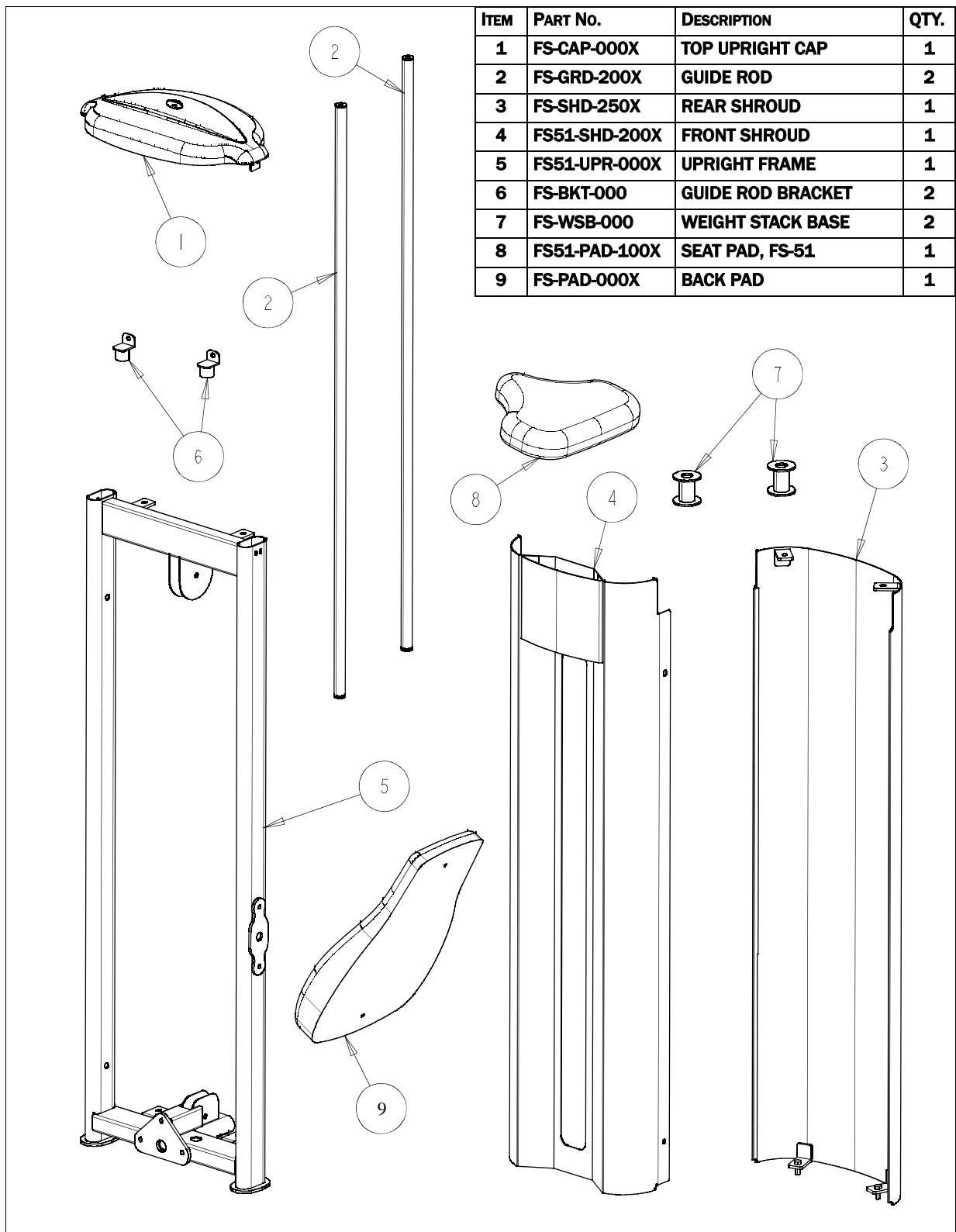

ITEM	PART No.	DESCRIPTION	QTY.
1	FS-CAP-000X	TOP UPRIGHT CAP	1
2	FS-GRD-200X	GUIDE ROD	2
3	FS-SHD-250X	REAR SHROUD	1
4	FS51-SHD-200X	FRONT SHROUD	1
5	FS51-UPR-000X	UPRIGHT FRAME	1
6	FS-BKT-000	GUIDE ROD BRACKET	2
7	FS-WSB-000	WEIGHT STACK BASE	2
8	FS51-PAD-100X	SEAT PAD, FS-51	1
9	FS-PAD-000X	BACK PAD	1

FS 51 Box 2 CARTON CONTENTS

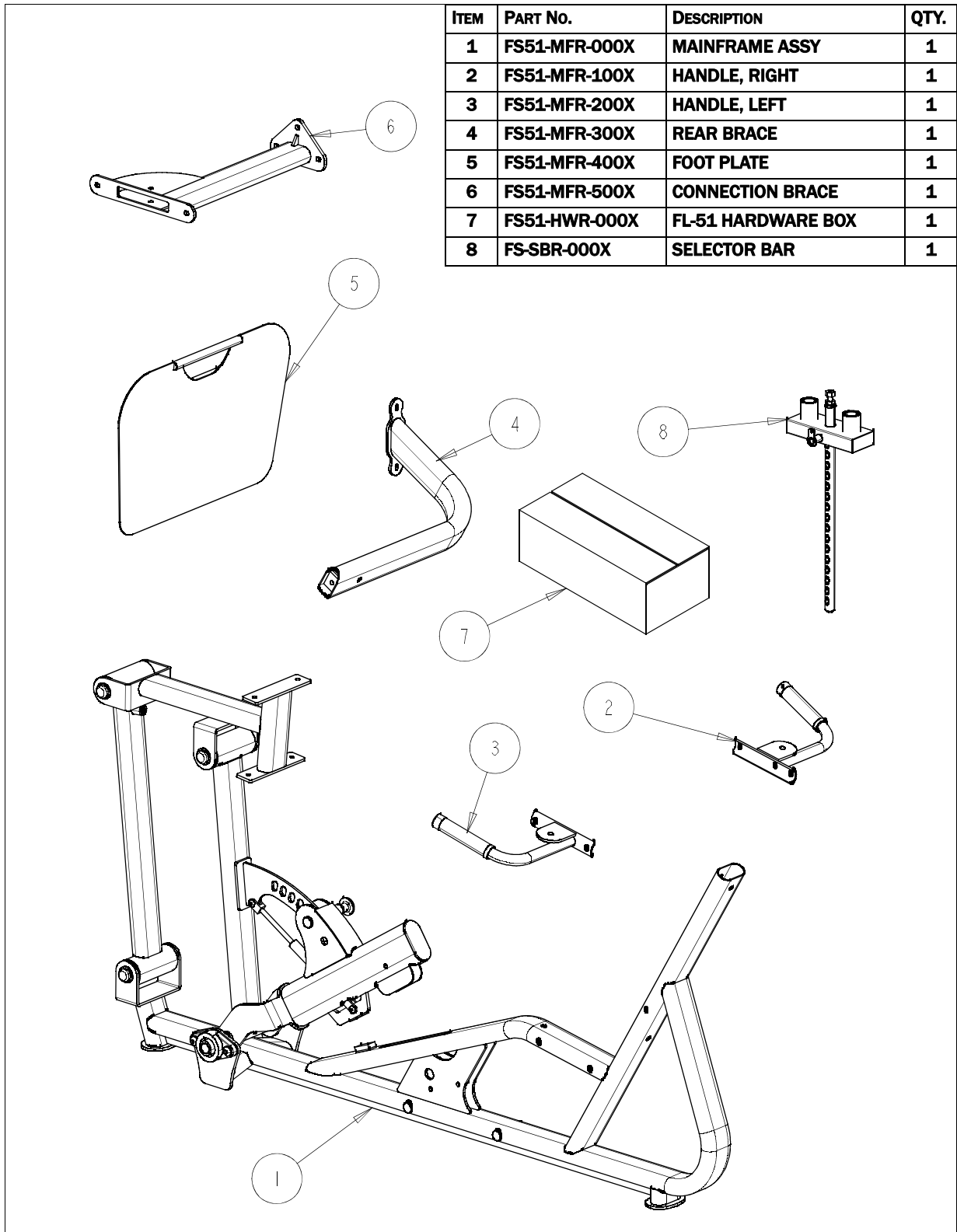

STEP 1: INSTALL THE LEG PRESS CABLE

1. Place the Leg Press frame squarely on the floor.
2. Route the cable as shown, installing the associated pulleys and hardware as you go along.
3. Make sure the cable and pulleys can move freely.
3. Tighten ALL the hardware

ITEM	PART No.	DESCRIPTION	QTY.
1	C-450	SCREW, 3/8"-16 X 2-1/2"	1
2	C-453	SCREW, 3/8"-16 X 2"	1
3	C-683	SHOULDER SCREW, 3/8" X 1-1/2"	1
4	C-754C	FLAT WASHER, 3/8"	6
5	C-955A	BASE, BOLT COVER, 3/8"	5
6	C-766A	LOCKNUT, 3/8"-16	2
7	C-731A	LOCKNUT, 5/16"-18	1
8	B-900	4-1/2" DIA. PULLEY	2
9	FL51-MFR-000X	MAINFRAME ASSEMBLY	1
10	FS51-CBL-100X	CABLE, LEG PRESS	1

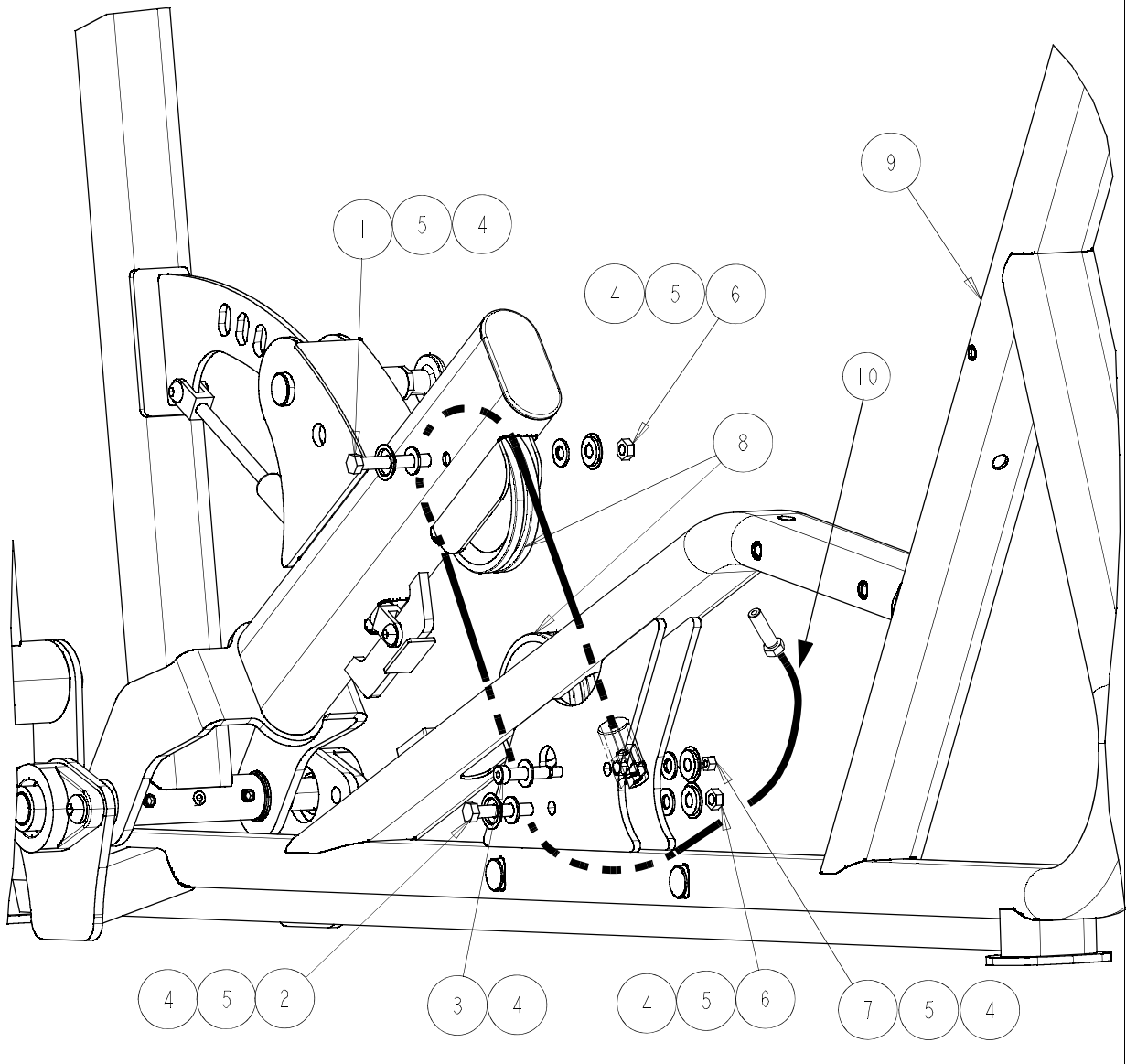

STEP 2: ASSEMBLE THE CONNECTING BRACE

1. Route the cable through the attachment piece as shown.
2. Loosely assemble ALL hardware and the pulley shown in this step.
3. DO NOT tighten the hardware until Step 4.
4. Make sure the cable and pulley can move freely.

ITEM	PART No.	DESCRIPTION	QTY.
1	C-955A	BASE, BOLT COVER, 3/8	3
2	FS51-MFR-500X	CONNECTION BRACE	1
3	C-445	SCREW, 3/8"-16 X 1"	2
4	C-448	SCREW, 3/8"-16 X 1-3/4"	1
5	B-898	6" DIA. PULLEY	1
6	C-754C	FLAT WASHER, 3/8"	3
7	C-749	LOCK WASHER, 3/8"	3

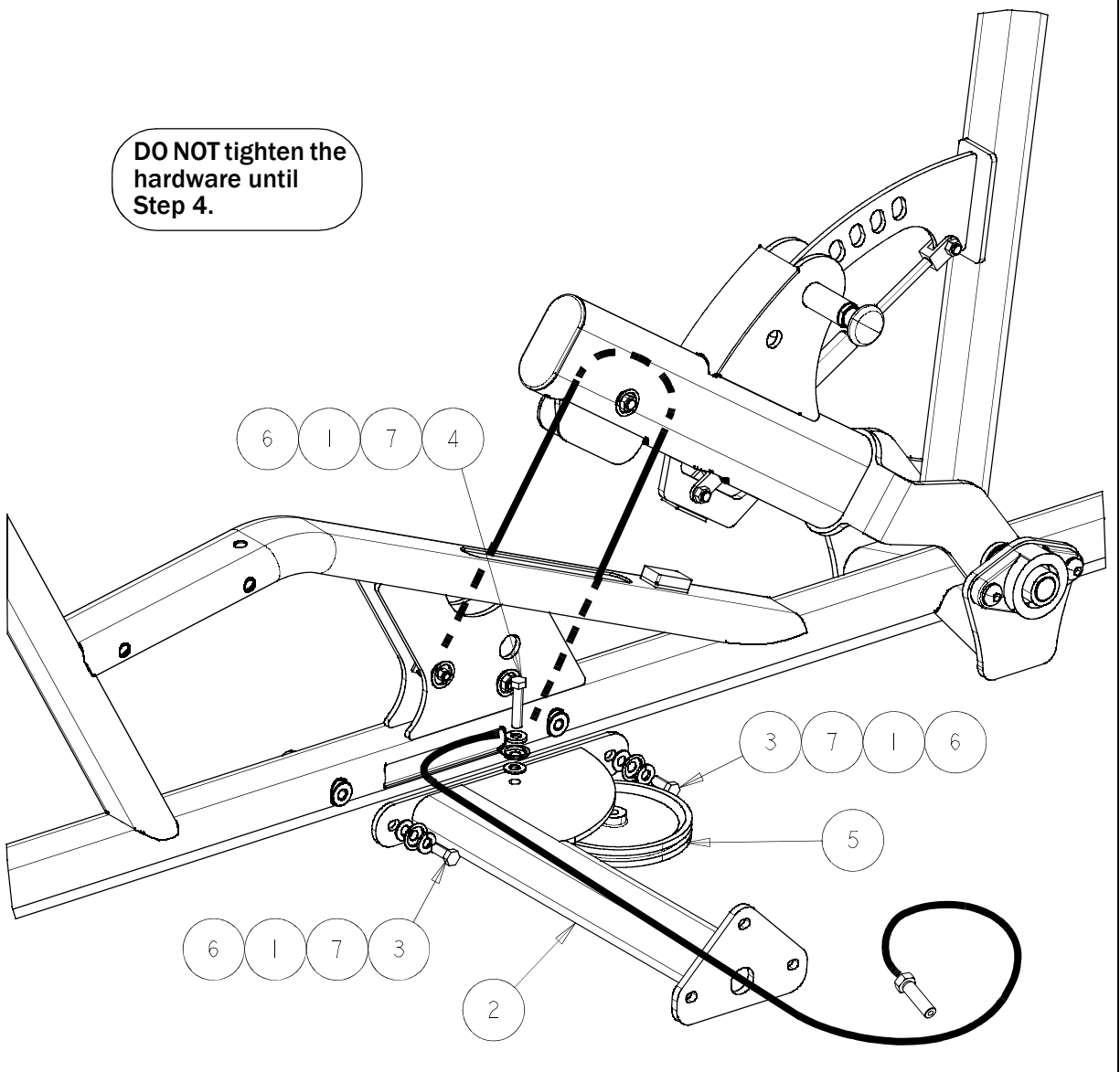

STEP 3: ASSEMBLE THE UPRIGHT FRAME

1. Place the upright frame squarely on the floor as shown.
2. Assemble the rubber feet on both the upright and Leg Press frame.
3. Route the cable through the upright frame as shown.
4. Loosely assemble all hardware.
5. Do not tighten the hardware until Step 4.

ITEM	PART No.	DESCRIPTION	QTY.
1	C-955A	BASE, BOLT COVER, 3/8"	3
2	FS51-UPR-000X	UPRIGHT FRAME	1
4	C-445	SCREW, 3/8"-16 X 1"	3
5	S-550	RUBBER FOOT	5
6	C-754C	FLAT WASHER, 3/8"	3
7	C-749	LOCK WASHER, 3/8"	3

DO NOT tighten the hardware until Step 4.

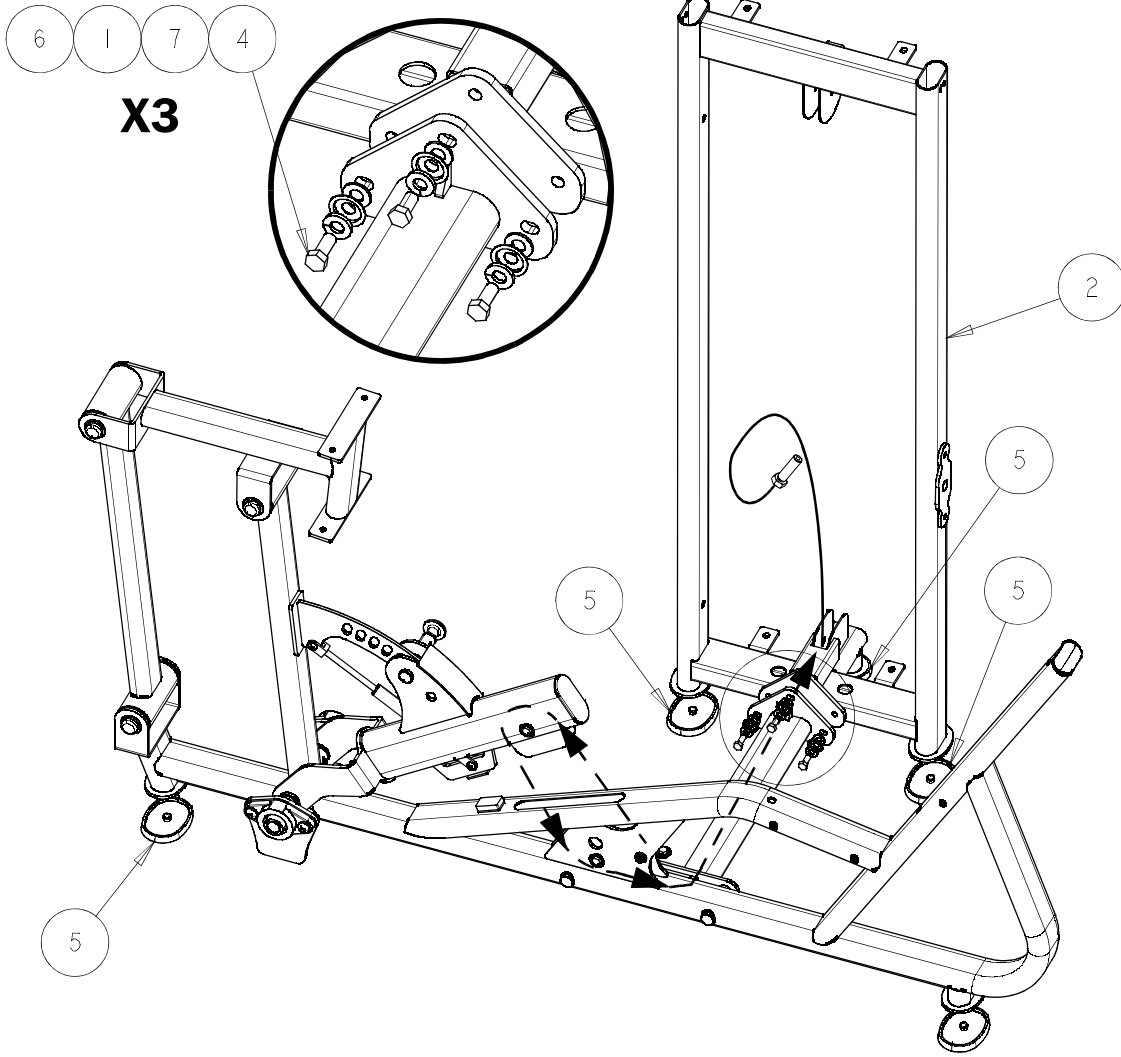

STEP 4: INSTALL THE REAR BRACE

1. Position the rear brace as shown.
2. Loosely assemble ALL hardware shown in this step.
3. After aligning all component edges and surfaces, tighten ALL the hardware from this step and from steps 2 and 3.

ITEM	PART No.	DESCRIPTION	QTY.
1	C-955A	BASE, BOLT COVER, 3/8"	3
2	FS51-MFR-300X	REAR BRACE	1
3	C-455	SCREW, 3/8"-16 X 4"	1
4	C-445	SCREW, 3/8"-16 X 1"	2
5	C 754C	FLAT WASHER, 3/8"	3
6	C-749	LOCK WASHER, 3/8"	3

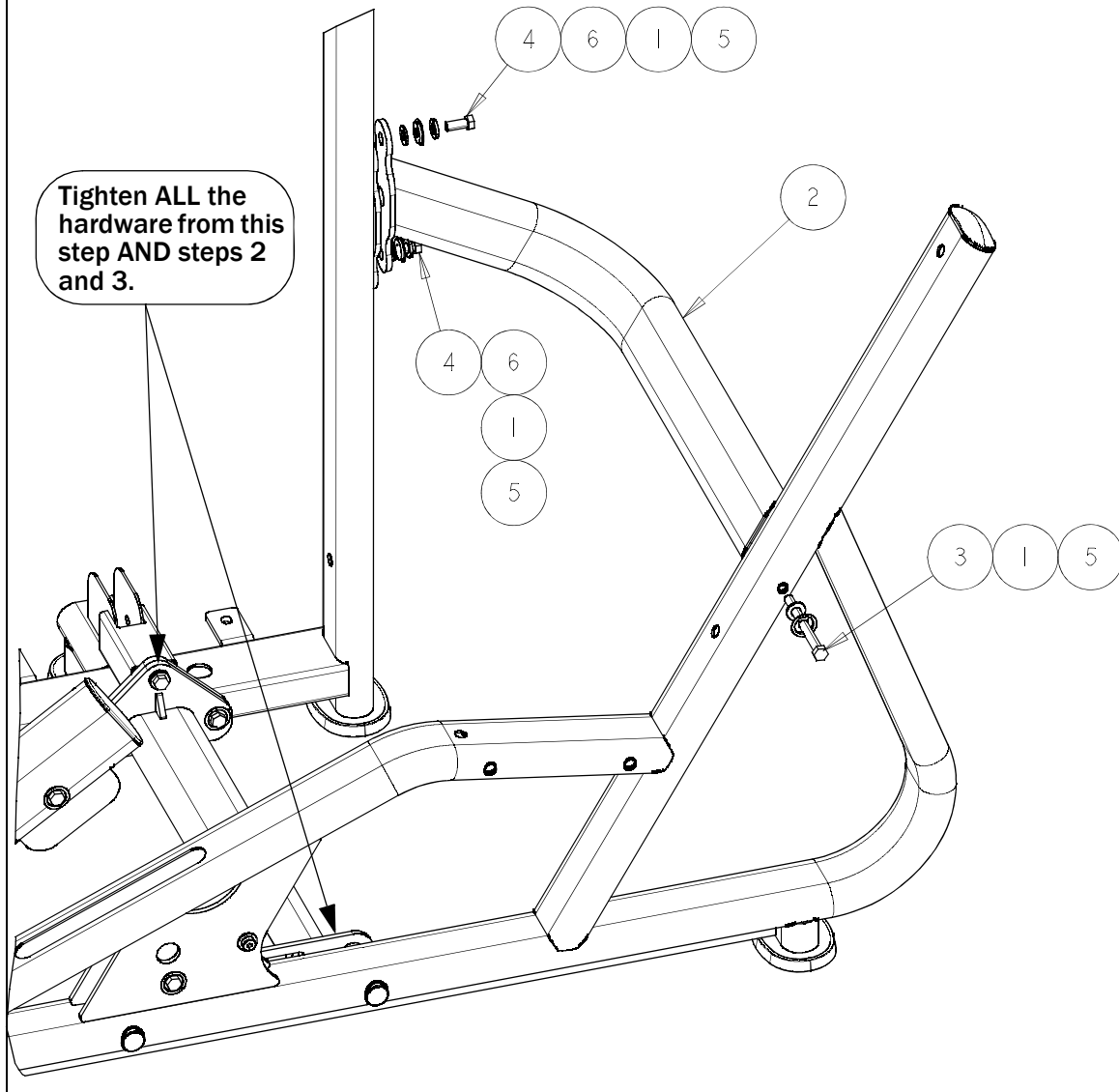

STEP 5: ASSEMBLE THE FOOT PLATE

1. Position the foot plate as shown.
2. Loosely assemble ALL hardware shown in this step.
3. After aligning all component edges and surfaces, tighten the hardware.

ITEM	PART No.	DESCRIPTION	QTY.
1	C-766A	LOCKNUT, 3/8"-16	4
2	C-955A	BASE, BOLT COVER, 3/8"	8
3	FS51-MFR-400X	FOOT PLATE	1
4	C-444	SCREW, 3/8"-16 X 3/4"	4
5	C-754C	FLAT WASHER, 3/8"	4

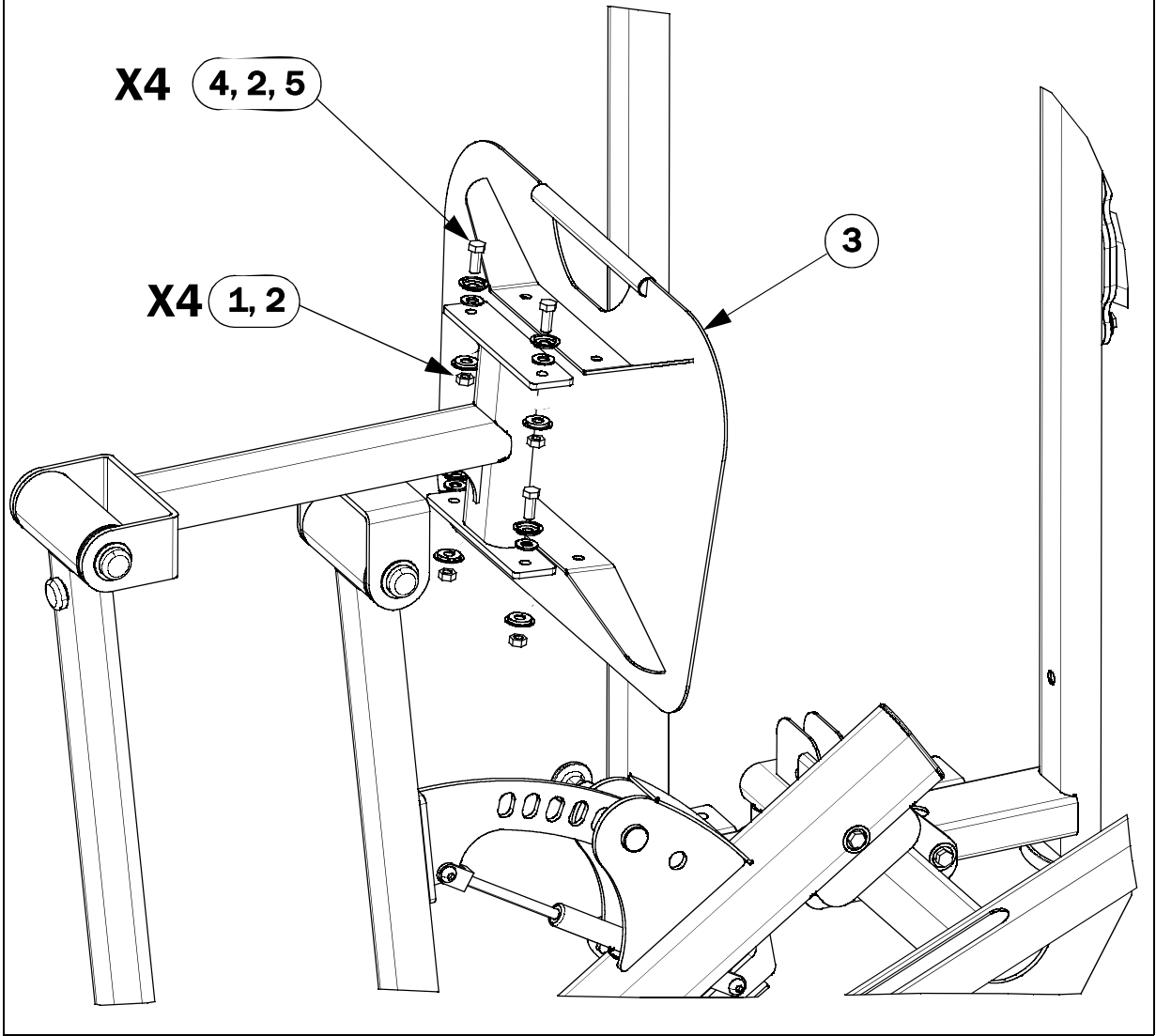

STEP 6: ASSEMBLE THE HANDLES

1. Position the handles as shown.
2. Loosely assemble ALL hardware shown in this step.
3. Do NOT tighten the hardware after installation.

ITEM	PART No.	DESCRIPTION	QTY.
1	C-766A	LOCKNUT, 3/8"-16	2
2	C-955A	BASE, BOLT COVER, 3/8"	4
3	FS51-MFR-100X	HANDLE, RIGHT	1
4	FS51-MFR-200X	HANDLE, LEFT	1
5	C-455	SCREW, 3/8"-16 X 4"	2
6	C-754C	FLAT WASHER, 3/8"	4

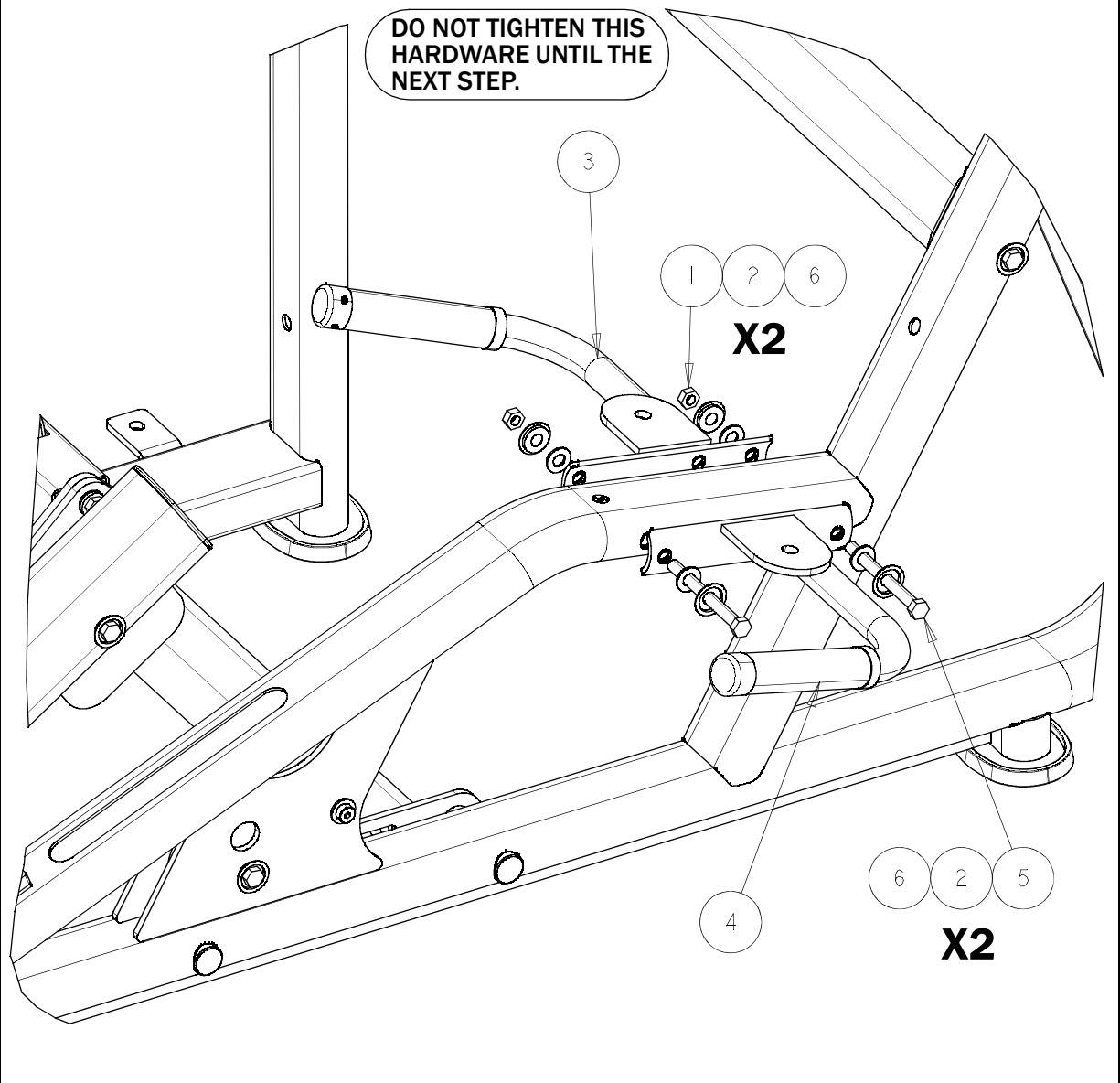

STEP 7: ASSEMBLE THE SEAT PAD

1. Position the seat pad as shown.
2. Loosely assemble ALL hardware shown in this step.
3. After aligning all component edges and surfaces, tighten the hardware.
4. Also, tighten all the hardware from the previous step.

ITEM	PART No.	DESCRIPTION	QTY.
1	C-955A	BASE, BOLT COVER, 3/8"	3
2	FL51-PAD-100X	SEAT PAD	1
3	C-446	SCREW, 3/8"-16 X 1-1/4"	2
4	C-451	SCREW, 3/8"-16 X 2-3/4"	1
5	C-754C	FLAT WASHER, 3/8"	3
6	C-749	LOCKWASHER 3/8"	3

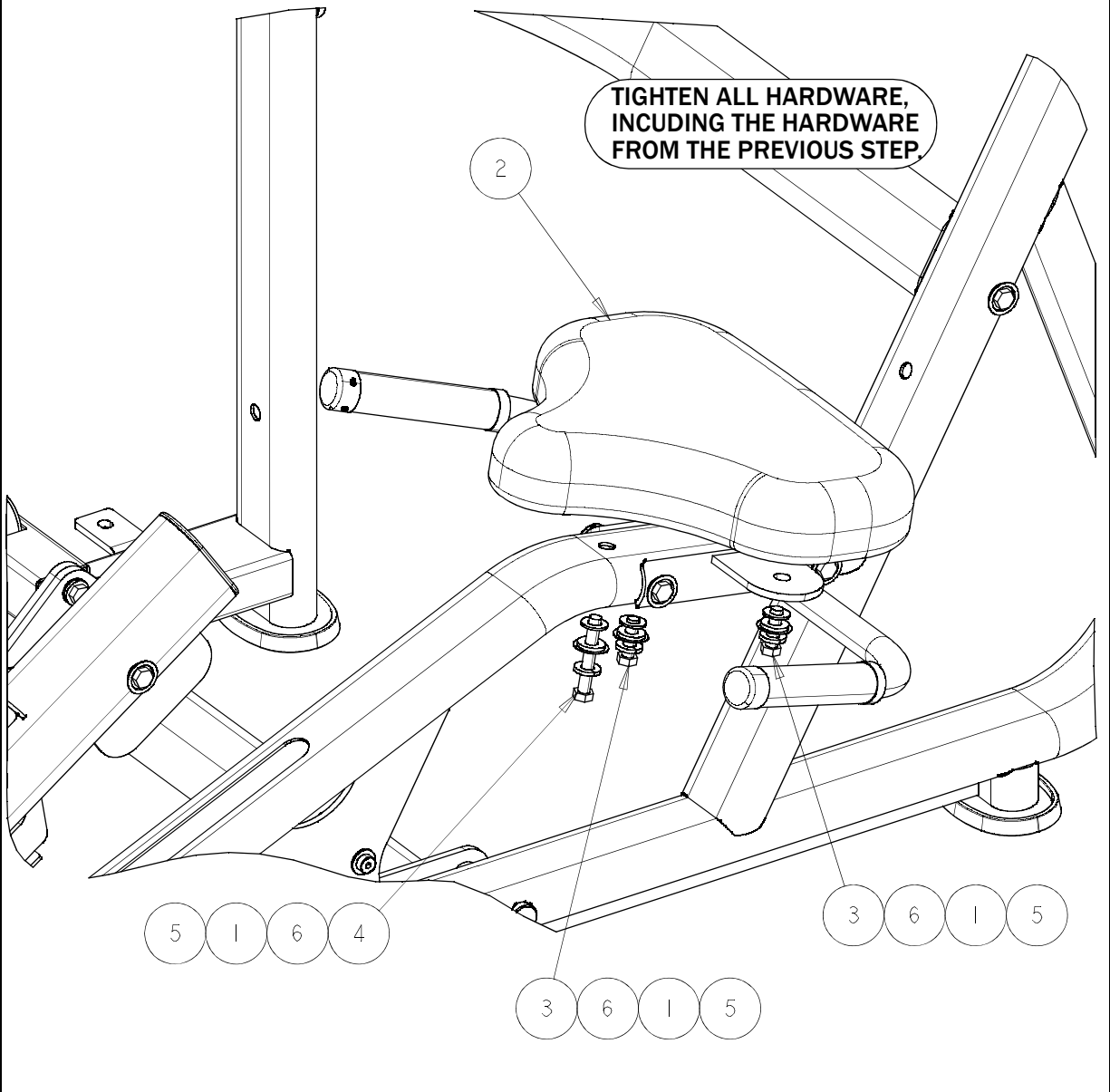

STEP 8: ASSEMBLE THE BACK PAD

1. Position the seat pad as shown.
2. Loosely assemble ALL hardware shown in this step.
3. After aligning all component edges and surfaces, tighten the hardware.

ITEM	PART NO.	DESCRIPTION	QTY.
1	C-955A	BASE, BOLT COVER, 3/8"	2
2	FS-PAD-000X	BACK PAD	1
3	C-451	SCREW, 3/8"-16 X 2-3/4"	2
4	C-754C	FLAT WASHER, 3/8"	2
5	C-749	LOCKWASHER, 3/8"	2

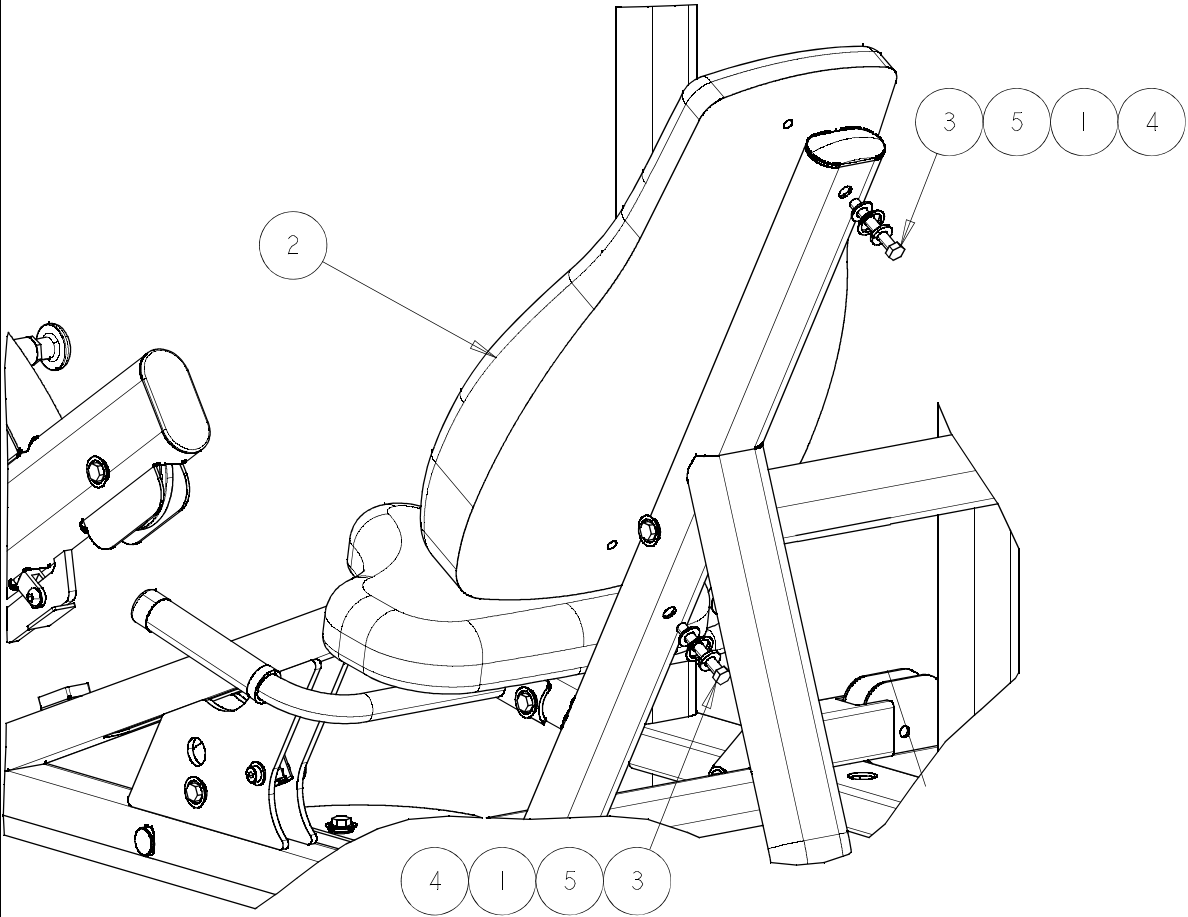

STEP 9: INSTALL THE UPRIGHT PULLEYS

1. Route the cable as shown, installing the associated pulleys and hardware as you go along.
2. Tighten ALL the hardware.
3. Make sure the cable and pulleys can move freely.

ITEM	PART NO.	DESCRIPTION	QTY.
1	C-766A	LOCKNUT, 3/8"-16	2
2	B-900	4-1/2" PULLEY	1
3	C-448	SCREW, 3/8"-16 X 1-3/4"	2
4	C-754C	FLAT WASHER, 3/8"	4

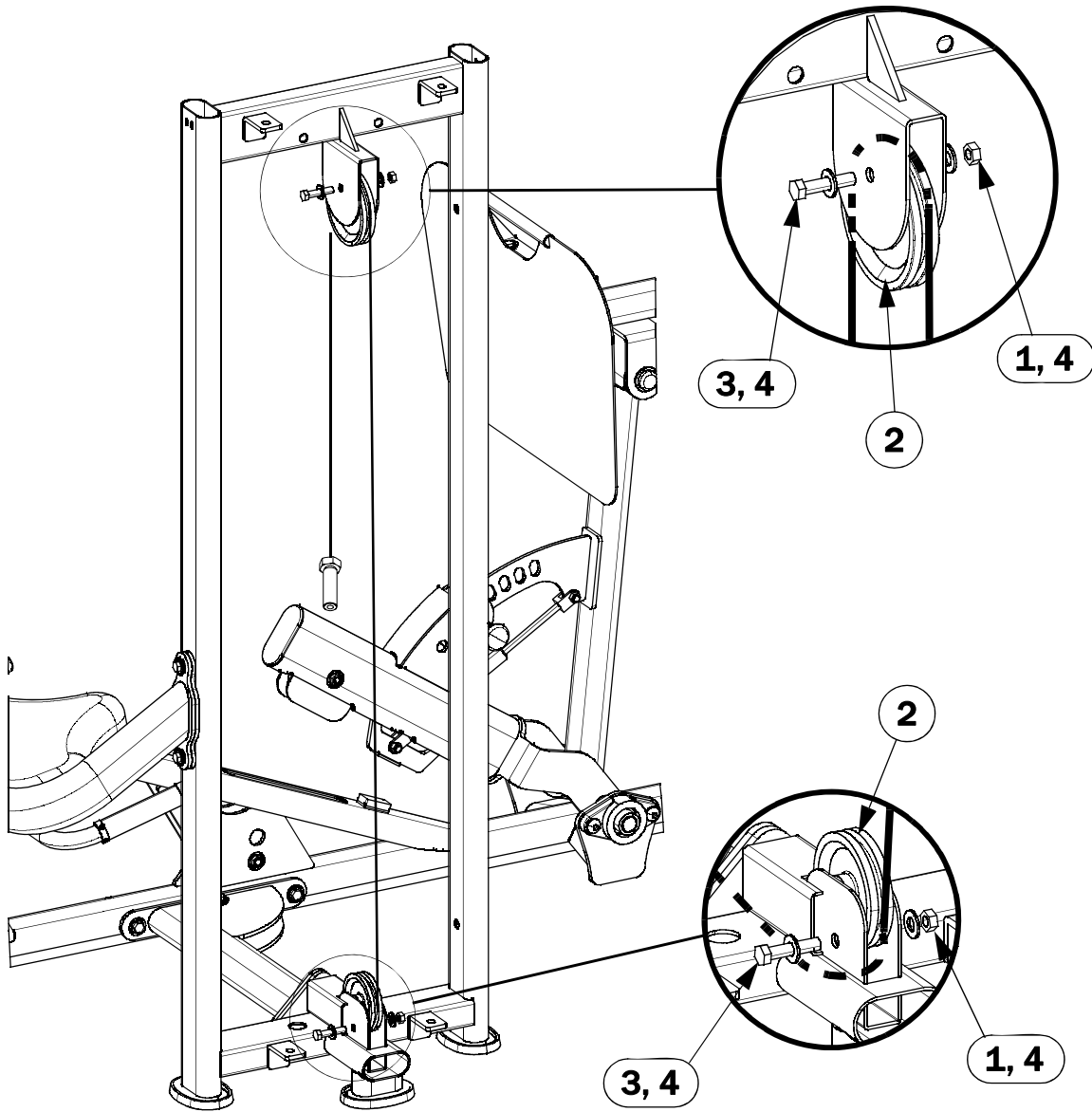

STEP 10: ASSEMBLE THE WEIGHT STACK

1. Route the Low Pulley cable as shown.
2. Install the pulleys and associated hardware as you go along.
3. Make sure the cable and pulleys can move freely.
4. Pin the top weight plate using the specified hardware as shown below.

ITEM	PART NO.	DESCRIPTION	QTY.
1	FS-GRD-200X	ASSY, GUIDE ROD	2
2	C-445	SCREW, 3/8"-16 X 1"	2
3	D 840	COLLAR, CLAMPING 1" ID	2
4	FS-BMP-001	WEIGHT STACK BUMPER	2
5	FS-WSB-000	WEIGT STACK BASE	2
6	FS-BKT-000	GUIDE ROD BRACKET	2
7	WHT-PLATE	WGT. PLT. 10# OR 15#	16
8	FS-SBR-00X	CAP PLATE ASSY	1
9	C 757A	FLAT WASHER, 1"	2
10	C 754C	FLAT WASHER, 3/8"	2
11	C 749	LOCKWASHER, 3/8"	2
12	C 955A	BOLT CAP, BASE	1
13	C 955	BOLT CAP, BLACK	1
14	C 461	SCREW, 3/8"-16 X 5-1/2"	1
15	C 766A	LOCK NUT, 3/8"-16	1
16	FS-SPN-000X	SELECTOR PIN	1

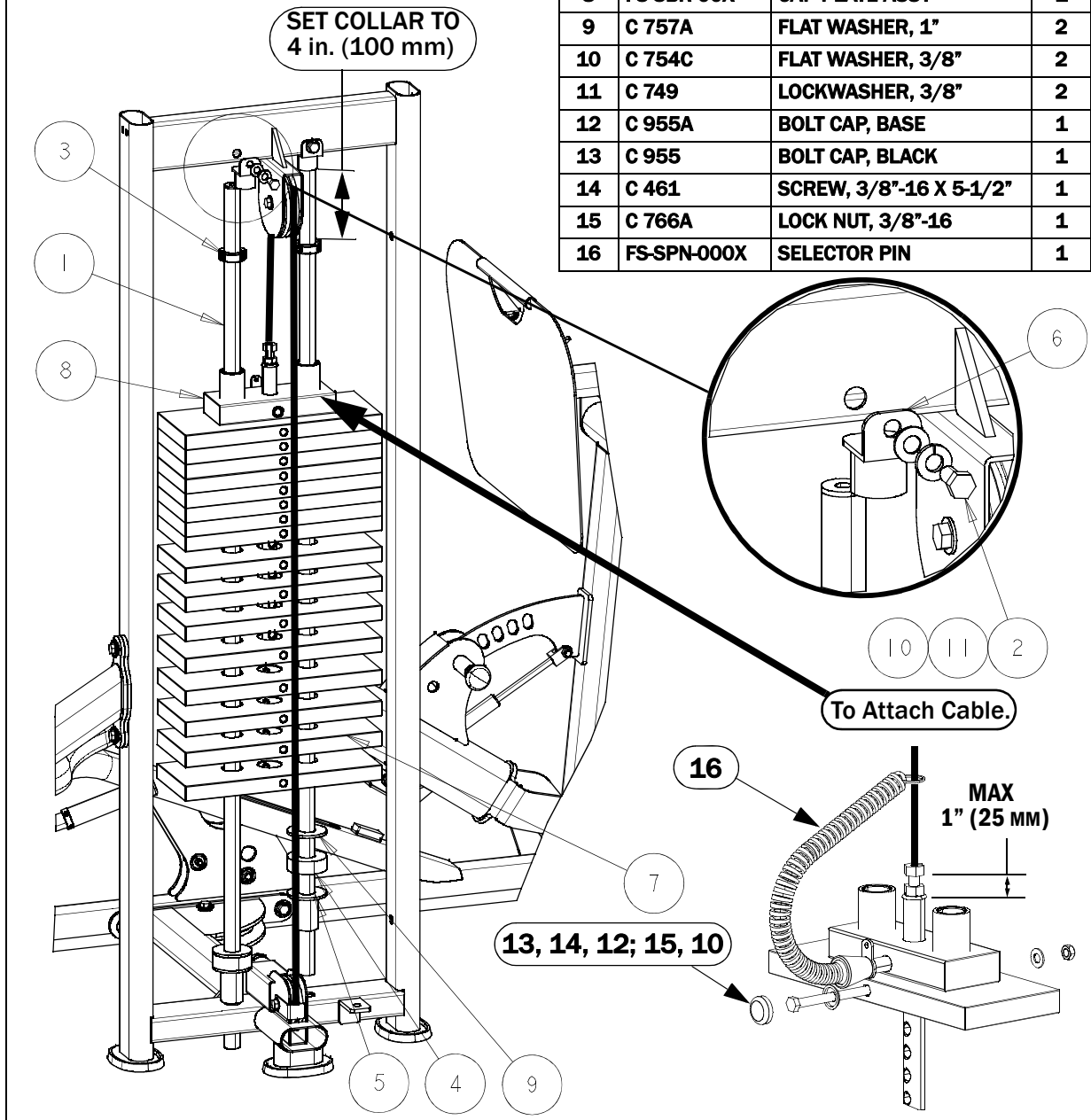

STEP 11: INSTALL THE FRONT SHROUD

1. Place the front shroud on the upright as shown.
2. Loosely assemble ALL the hardware shown in this step.
3. After aligning all the holes, tighten the hardware.

ITEM	PART No.	DESCRIPTION	QTY.
1	FS51-SHD-200X	FRONT SHROUD	1
2	C-445	SCREW, 3/8"-16 X1"	4
3	C-754C	FLAT WASHER, 3/8"	4
4	C-749	LOCKWASHER, 3/8"	4

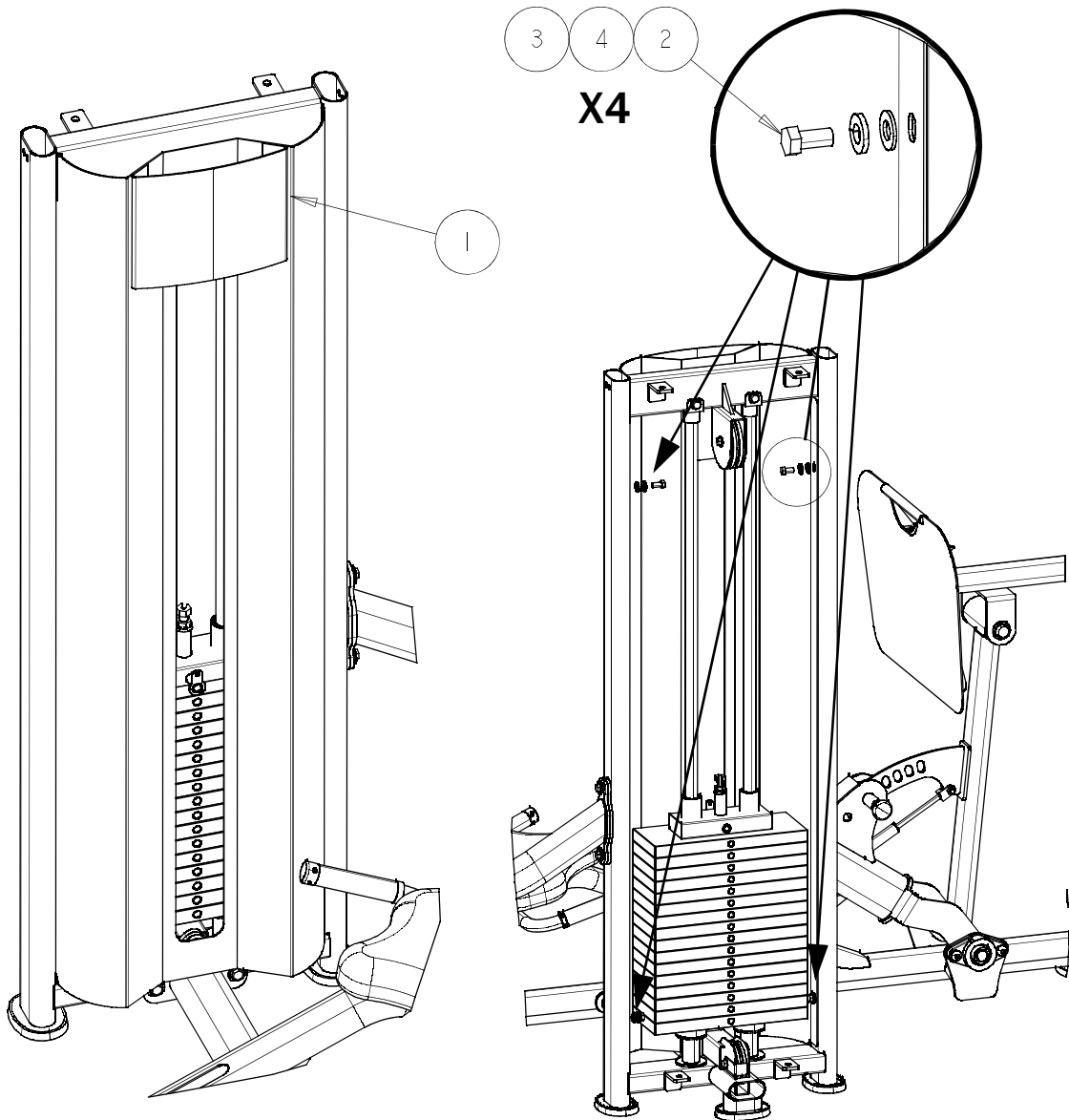

STEP 12: INSTALL THE REAR SHROUD

1. Place the lower rear shroud pegs into the corresponding holes at the bottom of the upright frame.
2. Align the holes in the top shroud retainers and loosely assemble the hardware.
3. After aligning all component edges and surfaces, tighten the hardware.

ITEM	PART NO.	DESCRIPTION	QTY.
1	FS-SHD-250X	REAR SHROUD	1
2	C-444	SCREW, 3/8"-16 X 3/4"	2
3	C-754C	FLAT WASHER, 3/8"	4
4	C-766A	LOCK NUT, 3/8"	2

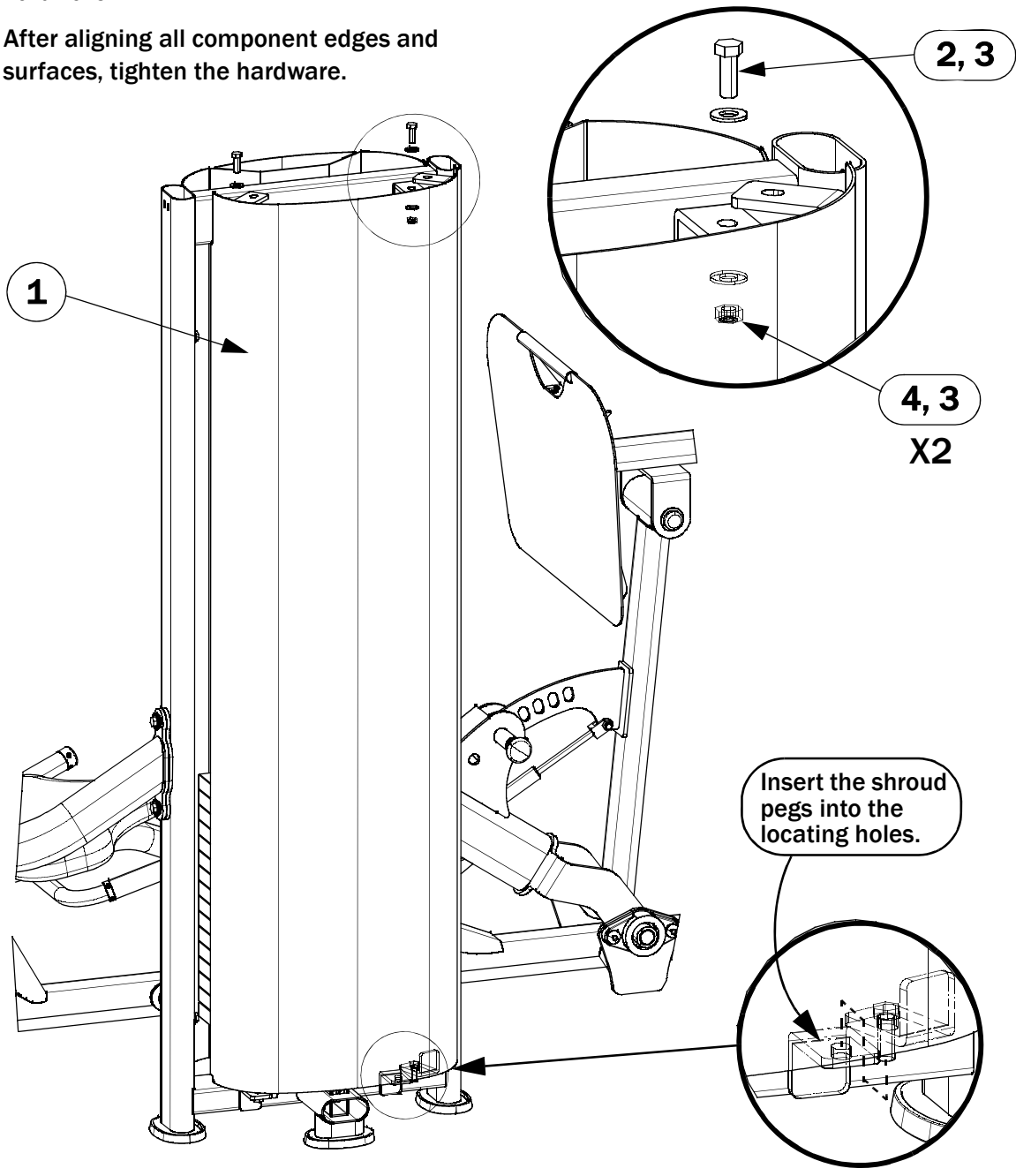

STEP 13: INSTALL THE TOP CAP

1. Assemble the top cap brackets as shown.

1. Lower the top cap on to the top of the upright.

2. Loosely assemble ALL the hardware shown in this step.

3. After aligning all component edges and surfaces, tighten the hardware.

ITEM	PART No.	DESCRIPTION	QTY.
1	FS-CAP-000X	TOP CAP	1
2	C 675D	SCREW, 1/4"-20 X 1/2", BHCS	8
3	FS-BKT-001	TOP CAP BRACKET	2

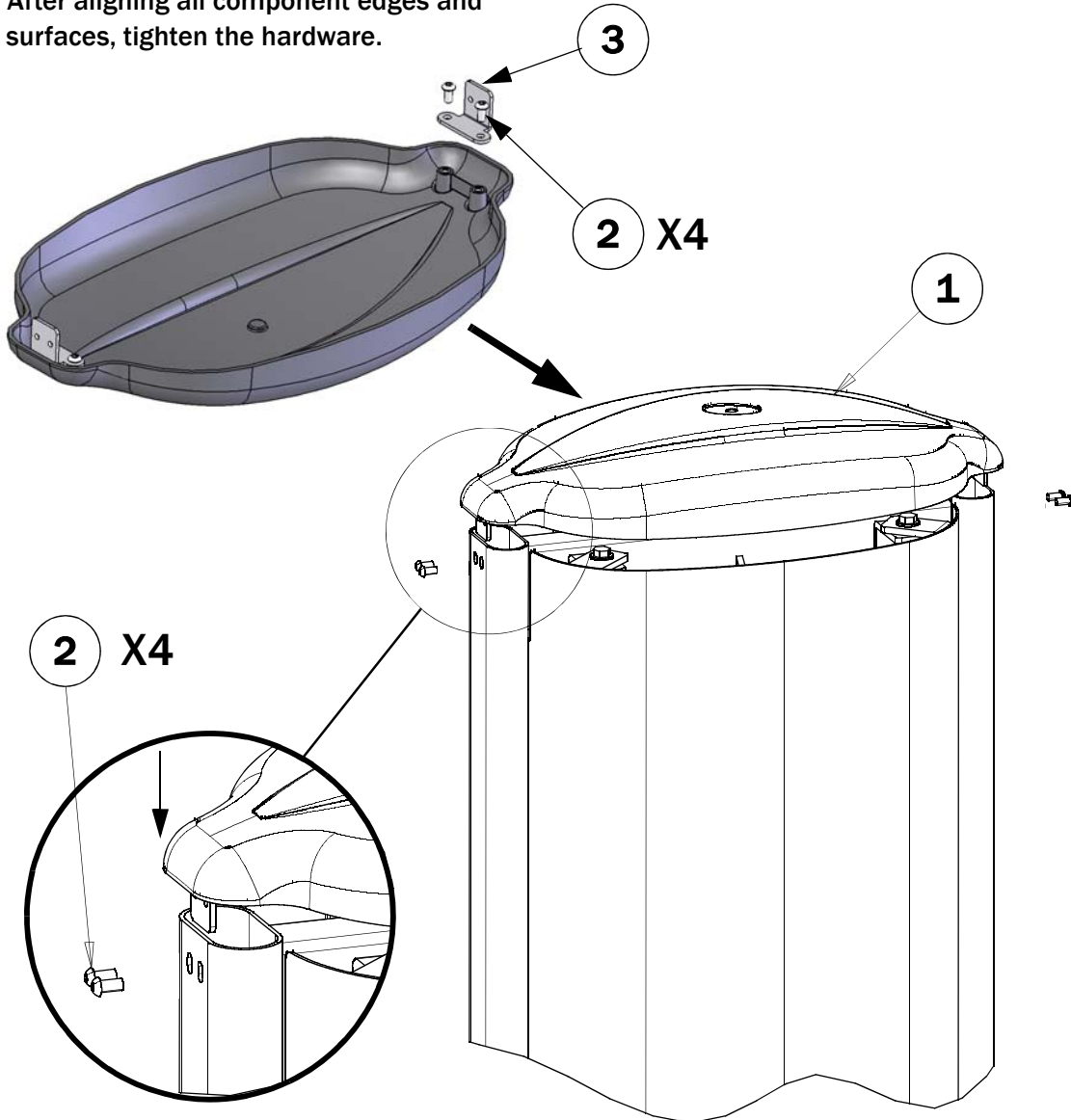

STEP 14: INSTALL THE BOLT CAPS

1. Assemble the plastic bolt caps to cover each exposed bolt on the machine. The caps will snap on to the bolt cap base installed with the hardware.

ITEM	PART No.	DESCRIPTION	QTY.
1	C-955	BOLT CAP	37

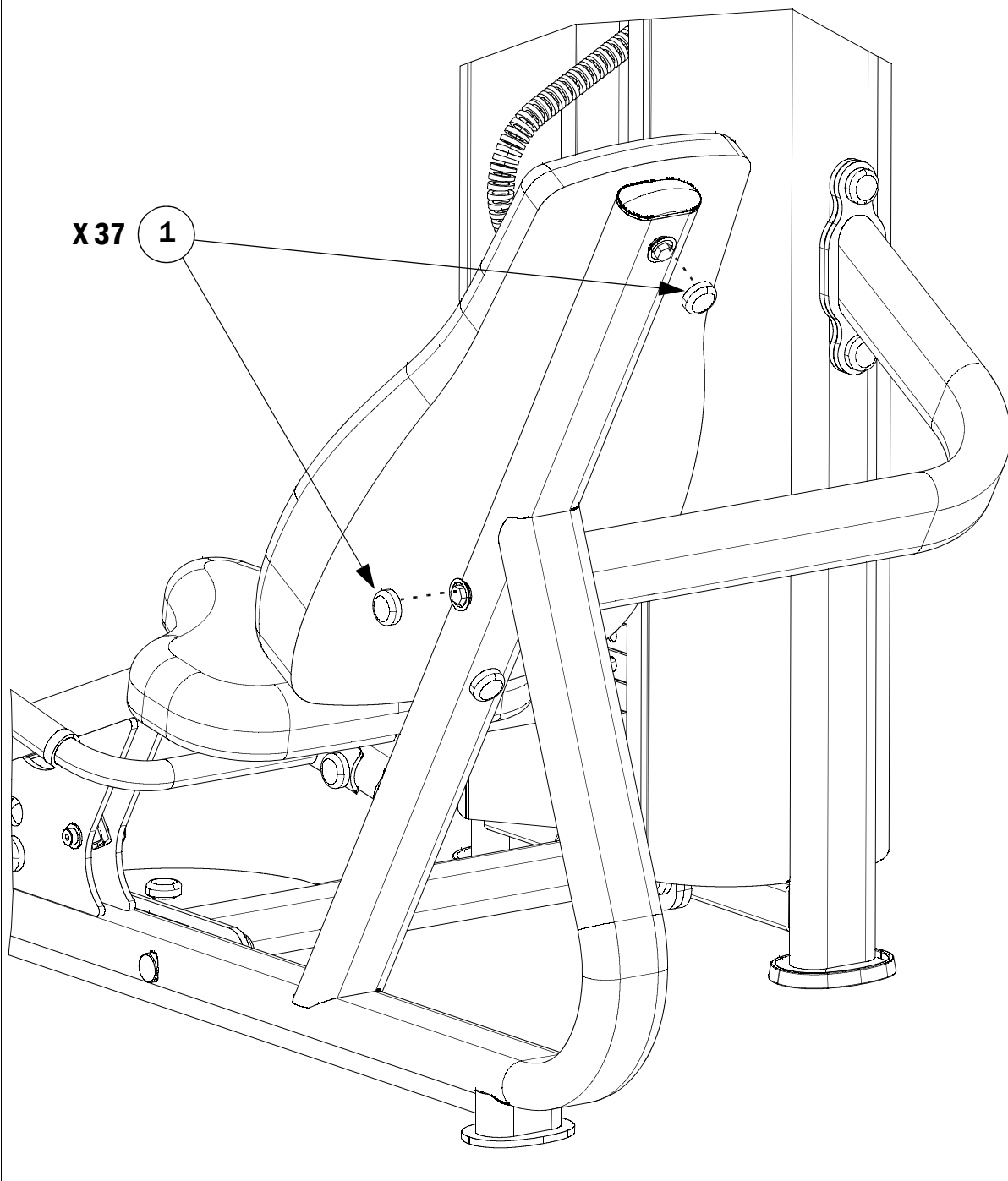

STEP 15: WEIGHT STACK LABEL

1. Select the appropriate weight stack label(s) according to your order. You can install pound labels, kilogram labels, or both.
2. If you ordered a 170 lb. weight stack, use labels:
LBL-WSE-01170 (for pounds)
LBL-WSM-01170 (for kilograms).
3. If you ordered a 250 lb. weight stack, use labels:
LBL-WSE-01250 (for pounds)
LBL-WSM-01250 (for kilograms).
4. Remove the backing from the label to expose the adhesive. Carefully locate the label on the shroud so that it is centered between the edge and the bend. Line up the numbers with their corresponding weight plate. Once the correct position is attained and the label is a uniform distance from the edge, press firmly along the entire length of the label.
5. NOTE: Adhesive takes 24 hours to fully set.

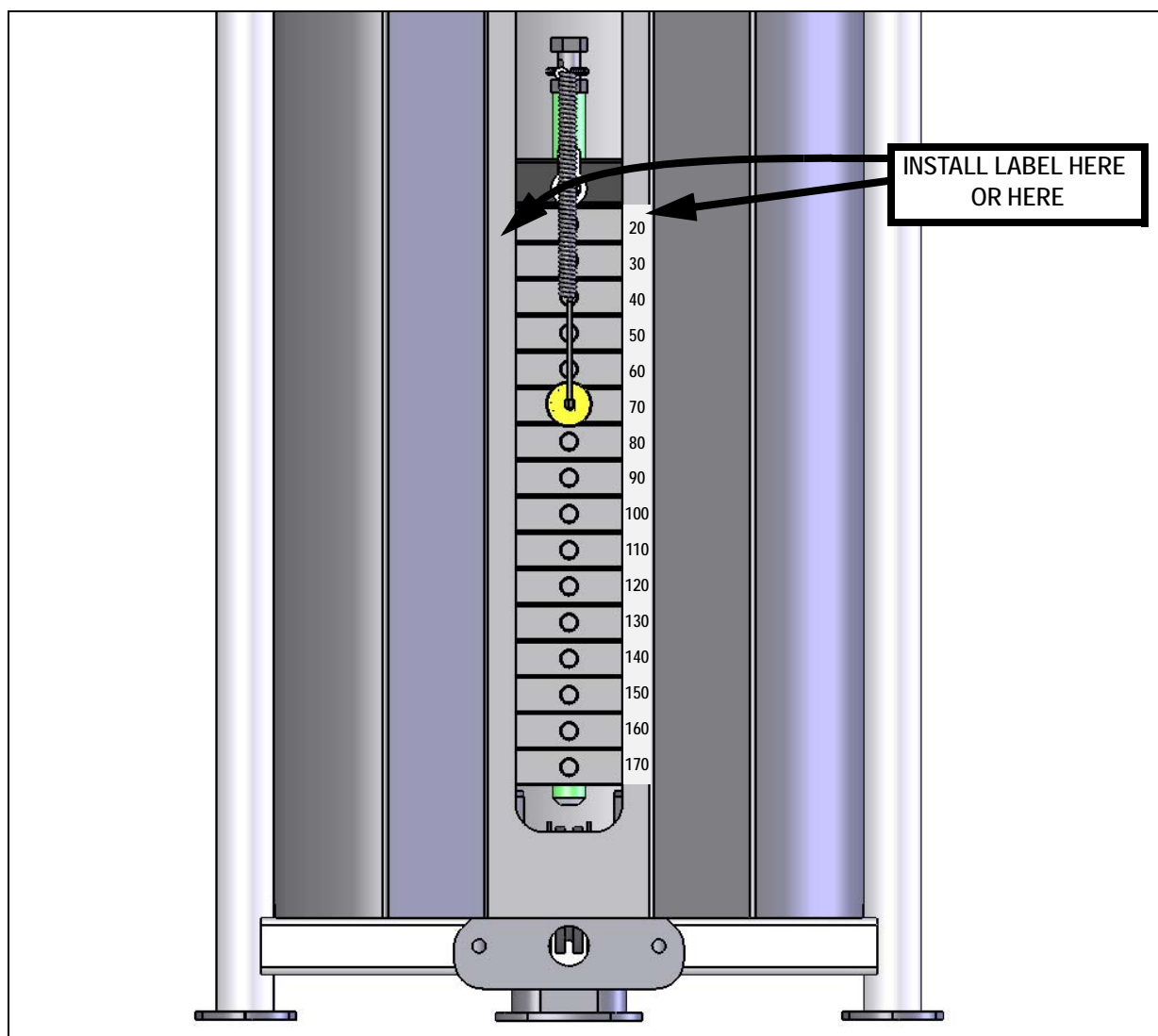

MACHINE LABELS

The following are the Warning labels required for this FS machine. If any of these labels are missing or become damaged, TRUE will replace them free of charge.

Note: these labels are not to scale.

WARNING

SERIOUS INJURY CAN OCCUR ON THIS EQUIPMENT. FOLLOW THESE PRECAUTIONS TO HELP AVOID INJURY.

- BEFORE USING: Read and understand all of the warnings and obtain instruction on the use of this machine. DO NOT modify the machine.
- Get a medical exam before beginning an exercise program.
- Keep body and clothing clear of all moving parts. DO NOT wear anything loose or dangling.
- Inspect the machine before use. DO NOT use if it appears damaged. DO NOT try to fix any machine. Notify staff immediately.
- INSPECT MACHINE DAILY for loose, worn or damaged parts. Replace any part or label at first signs of wear. Inspect all cables and their connections closely. If you are in doubt about any part, DO NOT use the machine until the part is replaced.
- Inspect all cables and connections before using the machine. DO NOT use this machine if any part appears worn or damaged.
- Be certain that weight pin is completely inserted. Use only the pin provided by Paramount. If unsure, seek assistance.
- NEVER pin weights or top plate into an elevated position. DO NOT use the machine if found in this condition. DO NOT try to fix. Seek assistance.
- Use only the incremental weights supplied by Paramount. DO NOT use dumbbells or other means to add resistance to machine.
- NEVER allow children near this machine. Supervise teenagers.
- DO NOT REMOVE THIS LABEL. REPLACE IF DAMAGED.

MAINTENANCE SCHEDULE

Check the integrity and function of the following items. Replace all worn components immediately.

Cables:	• Check tension, end fittings, and coating.	x
	• Check weight stack locking pin.	x
	• Replace cables annually.	x
Lubrication:	• Wipe down and dry.	x
	• Clean and condition.	x
Frame:	• Wipe down with damp cloth and dry.	x
	• DO NOT leave parts damp. Polish/Wax.	x
Chrome:	• Wipe down with damp cloth and dry.	x
	• DO NOT leave parts damp. Polish/Wax.	x
Nuts/Bolts/Plastnuts:	• Check tightness.	x
	• Grease and lubricate.	x
Guide Rods:	• Clean and lubricate.	x
Adjustable Locking Pins/Knobs:		x
Weight Stack Pins:		x
Warning/Instruction Labels:		x
Spring:		x
Intelli-Seat:		x
Hand Grips:		x

For recommended maintenance products refer to the owner's manual or Paramount's Web site www.paramountfitness.com
1-800-721-2121 LBL-WRN-0002 1006

25	20	11	9
40	30	18	14
55	40	25	18
70	50	32	23
85	60	39	27
100	70	46	32
115	80	52	36
130	90	59	41
145	100	66	45
160	110	73	50
175	120	80	54
190	130	86	59
205	140	93	64
220	150	100	68
235	160	107	73
250	170	114	77

WARNING

MAXIMUM Height Under Nut to Bolt Head. MAKE SURE locking nut is tight.

B2141C

B2141C

WARNING

WHEN DOING CALF RAISES, ALWAYS ADJUST THE FOOT PLATE TO THE FURTHEST POSITION POSSIBLE

LBL-WRN-0004

LBL-WRN-0004

WARNING

SERIOUS INJURY CAN OCCUR ON THIS EQUIPMENT IF THE CABLES AND THEIR ATTACHMENT COMPONENTS ARE NOT INSPECTED OFTEN. REPLACE AT FIRST SIGNS OF WEAR.

P/N B2051

B2051

TRUE

LEG / CALF PRESS

FS-51

- Read all warning labels.
 - If unit appears damaged or inoperable, do not try to use or fix. DO NOT use if weights are pinned in an elevated position. Seek staff assistance.
 - Choose light resistance when using machine for first time and train at controlled speed.

STARTING

QUADRICEPS

ENDING

GLUTEUS MAXIMUS
HAMSTRINGS
GASTROCNEMIUS

LEG PRESS

- From the seated position select desired weight amount.
- Adjust the foot platform so that your legs are bent approximately 90 degrees at the knees. Position feet shoulder width apart on the foot plate and grasp the handles on either side of seat.
- Press with the legs. Do not allow the knees to lock out at full extension.
- Return to initial position and repeat.
- When performing Calf Raises, adjust foot platform to furthest position possible.

LBL-PR-FS51B

LBL-PR-FS51

LBL-WRN-0002

WARNING

SERIOUS INJURY CAN OCCUR ON THIS EQUIPMENT IF THE PIN IS NOT COMPLETELY INSERTED BEFORE USE.

ASTM F1749 P/N B2065

B2065

If this machine is to be installed in a public use facility, ASTM F1749 requirements specify that the facility sign shown to the right is to be installed in plain view.

If you did not receive the facility sign with your order, you can obtain one free of charge from TRUE by calling 1-800-883-8783.

BE ALERT!

THE FITNESS EQUIPMENT IN THIS FACILITY PRESENTS HAZARDS WHICH, IF NOT AVOIDED, COULD CAUSE SERIOUS INJURY OR DEATH.

PRIOR TO USING THE EQUIPMENT, READ THE WARNING LABELS AND INSTRUCTION PLACARDS AFFIXED TO EACH MACHINE.

IF YOU ARE UNSURE ON HOW TO USE A MACHINE, SEEK THE ASSISTANCE OF OUR FLOOR PERSONNEL. WE WILL BE HAPPY TO INSTRUCT YOU ON HOW TO USE THE EQUIPMENT PROPERLY.

IMMEDIATELY REPORT ANY PIECE OF EQUIPMENT THAT IS NOT FUNCTIONING PROPERLY TO OUR FLOOR PERSONNEL SO THAT IT MAY BE EVALUATED AND SERVICED PROMPTLY.

DO NOT ATTEMPT TO USE OR FIX ANY PIECE OF EQUIPMENT THAT IS NOT FUNCTIONING PROPERLY

ASTM F1749-96

SERVICE

HOW TO OBTAIN SERVICE

For warranty service, contact an Authorized TRUE Dealer or a TRUE Customer Service representative at 1-800-883-8783 or by e-mail at service@truefitness.com. Before you call, please have the following information ready.

- **Model Number:** FS-51 LEG PRESS
- **Serial Number:** _____
- **Date of Installation:** _____
- **A brief description of the problem**

The serial number is located on the front of the upright frame at the bottom as shown.

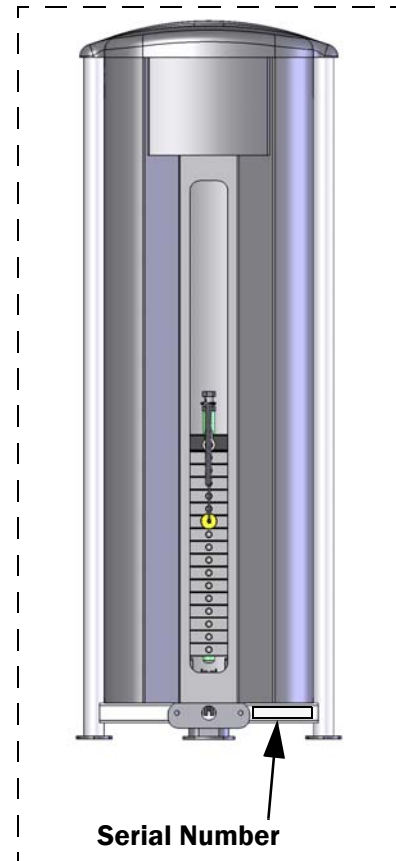

FINAL CHECK

1. If you haven't already done so, lubricate the guide rods and seat adjustment tubes with a teflon spray lubricant. TRUE recommends using TriFlow™ brand.
2. Adjust the foot plate through each position. Verify that the adjustment pin inserts freely into each position and is fully engaged.
3. Place the selector pin into the holder on the cap plate. Push the foot plate out slowly until it tops out against the stop. Verify that the cable moves freely, without any binding.
4. Verify that the selector pin can be inserted into each weight plate.
5. Perform the exercise to verify the cable routes smoothly and the machine operates correctly.

FS BOLT DOWN INSTRUCTIONS

The machines in this product line were designed and tested to meet the ASTM (American) and EN (European) safety standards for stability (without floor anchors) when the machine is used for its intended purpose as designated by the manufacturer.

However, TRUE strongly recommends that all equipment be anchored to the floor to prevent movement and increase stability.

- You will need to order an anchoring kit for each machine. This kit will include brackets and instructions for securing the brackets to the machines. Note: the kit does not include the floor anchor bolts. Order part number: FS-BLTDN-000X, 1 kit per FS machine.
- Due to the wide variation of flooring on which the unit can be installed, contact a qualified contractor to determine an appropriate fastening system for your floor.
- Use 3/8" diameter hardware (10 mm) to anchor the machine. Anchors should have a minimum pull out force of 220 lbs (110 kgs) for each position.
- When attaching the machine to the floor, if there is a gap between the machine foot (or bracket) and the floor, do not use the anchor to remove the gap as this can cause the machine frame to deform. Instead, place a shim between the bottom of the foot and the floor, then tighten the anchor.

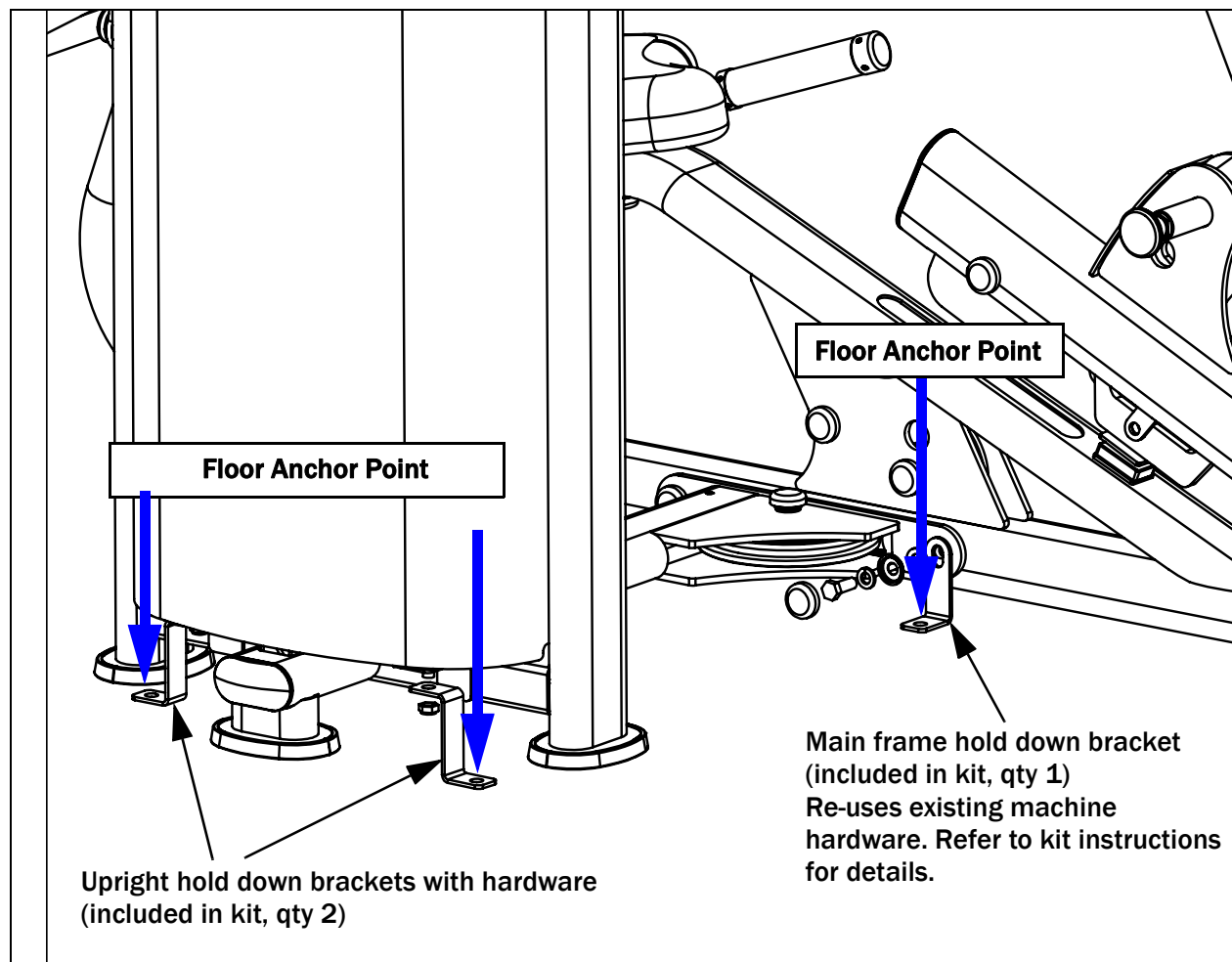

Save Time and Register Online!
 Activate Multiple Warranties at truefitness.com

All TRUE® Fitness products are distributed by TRUE and are warranted to the original registered product purchaser and the parts of the TRUE product (the "Product") listed below, under normal use and service, shall be free of manufacturing defects in workmanship and materials only for the period of time beginning from the original date of purchase set forth below:

Frame*	10 Years
Parts	
Bearings, Bushings, and Weight Plates	5 Years
Guide Rods and Pulleys	5 Years
Cables and Belts	1 Year
Cosmetics, Coatings, Grips, and Upholstery	3 Months
Labor	
Frame	1 Year
Bearings, Bushings, Weight Plates	1 Year
Guide Rods and Pulleys	1 Year
Cables and Belts	1 Year
Cosmetics, Coatings, Grips, and Upholstery	3 Months

- NOTE: Warranty valid for USA and Canada only.
- NOTE: Failure to register this product will result in no servicing or authorization of parts to be shipped.
- NOTE: Buying after-market products from a 3rd party will result in voided warranty.
- NOTE: This product is intended for Commercial use. If this product will not be used in this particular setting, please contact TRUE as is warranty is void.

Frame: The frame is warranted for defects in material and workmanship for a 10 years. The frame is warranted for labor and freight (for parts shipped from TRUE) for one year from date of purchase. * This limited warranty on structural frame does not include paint or coatings.

Parts: The FS Strength Line's mechanical parts are warranted for defects in material and workmanship for five years with one year labor warranty. Cables and belts are warranted for defects in material and workmanship for one year with one year labor warranty. This limited warranty does not cover damage or equipment failure resulting from or caused by improper assembly/installation, failure to follow instructions and warnings in owner's manual, accident, misuse, abuse, unauthorized modification, or failure to provide reasonable and necessary maintenance.

Cosmetics: The FS Strength Line cosmetic parts, coatings, grips and upholstery are warranted for defects in material and workmanship for three months with labor warranty to match the parts warranty period. This limited warranty does not cover damage or equipment failure resulting from or caused by improper assembly/installation, failure to follow instructions and warnings in owner's manual, accident, misuse, abuse, unauthorized modification, or failure to provide reasonable and necessary maintenance. This limited warranty will apply to, but may not be limited to, plastic covers, shrouds, caps, badges, overlays, paint, coatings, soft step inserts, and grips.

Labor: Labor is covered for a period of one year from the date of purchase unless otherwise expressed within this limited warranty as long as a TRUE authorized service provider performs the service. Service that requires over 50 miles of travel may be subject to additional charges. Reasonable and necessary maintenance guidelines can be found in the owner's manual.

Claims Procedure: TRUE Limited Warranty service may be obtained by contacting the authorized TRUE dealer from whom the Product was purchased. If the dealer from whom the Product was purchased is no longer an authorized TRUE dealer, then TRUE Limited Warranty service may be obtained by contacting TRUE directly using the following contact information:

TRUE Fitness, Service Department
 865 Hoff Road, St. Louis, MO 63366
 1.800.883.8783
 Hours of operation 8:30am - 5:00 pm CST

Save Time and Register Online! Activate Multiple Warranties at truefitness.com

The above Limited Warranty is subject to and will be in accordance with the conditions set forth below:

- 1. THIS LIMITED WARRANTY GIVES YOU SPECIAL LEGAL RIGHTS AND YOU MAY ALSO HAVE OTHER RIGHTS, WHICH VARY FROM STATE TO STATE.**
2. This Limited Warranty can be processed only if the Warranty Registration Form is completed online, or if the attached form is filled in, signed by the original purchaser, and mailed to TRUE within 30 days of purchaser's receipt of this Product. The serial number must be intact on the Product for this Limited Warranty to be valid.
3. This Limited Warranty applies to the product only while the Product remains in the possession of the original purchaser and is not transferable
4. This Limited Warranty becomes VALID ONLY if the Product is initially assembled/installed by a TRUE authorized dealer/technician (if anyone other than a TRUE authorized dealer/technician initially assembles and installs the Product, this Limited Warranty will be void unless the written authorization of TRUE is first obtained).
5. This Limited Warranty does not cover damage or equipment failure resulting from or caused by improper assembly/installation, failure to follow instructions and warnings in owner's manual, accident, misuse, abuse, unauthorized modification, or failure to provide reasonable and necessary maintenance (as referenced in the owner's manual.)
6. This Limited Warranty applies only to the cost of repair or replacement of parts and does not include labor (beyond the above warranty period), transportation, service, return and freight charges associated therewith except as expressly specified herein.
7. This Limited Warranty shall not apply to: Service calls to correct installation of the equipment or instruction to owners on how to use the equipment; or any labor costs incurred beyond the applicable labor warranty period.
8. This Limited Warranty, which is given expressly and in lieu of all other express warranties, constitutes the only warranty made by TRUE.
- 9. ANY IMPLIED WARRANTY, INCLUDING WITHOUT LIMITATION THE WARRANTIES OF MERCHANTABILITY AND FITNESS FOR A PARTICULAR PURPOSE, IS LIMITED IN DURATION AND REMEDY TO THE TIME PERIOD COVERED BY THE LIMITED WARRANTY. SOME STATES DO NOT ALLOW LIMITATIONS ON HOW LONG AN IMPLIED WARRANTY LASTS, SO THE ABOVE LIMITATION MAY NOT APPLY TO YOU.**
- 10. THE REMEDIES DESCRIBED ABOVE ARE YOUR SOLE AND EXCLUSIVE REMEDIES AND TRUE'S ENTIRE LIABILITY**

FOR ANY BREACH OF THIS LIMITED WARRANTY. TRUE'S LIABILITY SHALL UNDER NO CIRCUMSTANCES EXCEED THE ACTUAL AMOUNT PAID BY YOU FOR THE PRODUCT, NOR SHALL TRUE UNDER ANY CIRCUMSTANCES BE LIABLE FOR ANY CONSEQUENTIAL, INCIDENTAL, SPECIAL, OR PUNITIVE DAMAGES OR LOSSES, WHETHER DIRECT OR INDIRECT. SOME STATES DO NOT ALLOW THE EXCLUSION OR LIMITATION OF INCIDENTAL OR CONSEQUENTIAL DAMAGES, SO THE ABOVE LIMITATION OR EXCLUSION MAY NOT APPLY TO YOU.

NOTE TO AUTHORIZED WARRANTY LABOR PROVIDERS:

Warranty labor reimbursement or warranty parts rights may not be transferred to, reassigned to, a third party without the express written consent of TRUE. Even jobbing out warranty labor requires TRUE's written approval.

FS STRENGTH LINE SERIAL NUMBER:

The FS-51 comes with one serial number on the base of the machine. Please write down your serial number below and keep for your records.

SERIAL NUMBER:

SAMPLE SERIAL NUMBER STICKER:

Keep this page for your records

Thank you for purchasing a TRUE product. To validate the TRUE product warranty the fast and easy way, please go on-line now to truefitness.com/support and register your product. The information you provide will never be distributed to any other individuals or agencies for any purpose. If you prefer to mail your warranty card, have the owner of the product complete the information below and return it to TRUE Fitness within 30 days from the date of equipment installation.

To mail your warranty information, please fill in the information below and mail to: Service Dept., TRUE Fitness, 865 Hoff Road, St. Louis, MO 63366 (or save postage and register online at truefitness.com)

Commercial Warranty Registration

**PLEASE PROVIDE YOUR SERIAL NUMBER BELOW.
REQUIRED FOR WARRANTY REGISTRATION:**

SERIAL NUMBER:

Model Type _____

Date of Purchase _____

Your Company Name _____

Contact First Name _____

Contact Last Name _____

Address _____

City _____ State _____ ZIP _____

Email Address _____ Website _____

Phone _____ Fax _____

1. Where did you first learn about TRUE?

- a. Dealer b. Website
 c. Advertisement d. Referral
 e. Current Customer f. Other _____

2. Why did you purchase a TRUE product?

- a. Design/Appearance b. Dealer Suggestion
 c. Price/Value d. Quality Construction
 e. Performance f. TRUE Reputation
 g. Other _____

3. Please indicate your type of facility:

- a. Apartment/Condo b. Corporate Fitness Center
 c. Municipality d. Health Club/Gym/Spa
 e. Hotel/Resort f. Military Base
 g. Student Rec Center h. Other

4. What other types of equipment does your company ly own?

- a. Treadmill Brand _____
 b. Bike Brand _____
 c. Elliptical Brand _____
 d. Free Weights/Gym Brand _____

5. How many people use your facility on a daily basis?

- a. <25 b. 25-75
 c. 76-150 d. 150+

6. Do you plan to purchase more fitness equipment in the next 6-12 months?

- Yes No

7. If you answered "yes" to question 6, what type do you plan to purchase?

- a. Treadmill b. Elliptical
 c. Stationary Bike d. Free Weights
 e. Gym f. Other _____

8. Would you recommend TRUE to other club owners?

- Yes No

9. You are a valued TRUE customer and your suggestions allow us to continually improve your experience. Is there anything else you would like us to know? Please explain: