



FS-23
VERTICAL KNEE RAISE/CHIN/DIP
ASSEMBLY MANUAL

Model: FS-23
REV: 030620

A MESSAGE TO OUR CUSTOMERS

Frank Trulaske began TRUE Fitness® over thirty-five year ago with the simple philosophy of delivering superior fitness products, service, and support. Today, TRUE is the global leader in premium fitness equipment for the commercial and residential markets. Our goal is to be the leader in technology, innovation, performance, safety and style. TRUE has received many awards for its product over the years and remains the benchmark for the industry. Fitness facilities and consumers invest in TRUE products for their durable commercial platforms used in all its products, both commercial and residential alike.

The proud manufacturing tradition of quality and the culture of innovation at TRUE have given rise to a full line of extraordinary cardio and strength equipment. As a result, people all over the world are benefiting from the TRUE experience. Innovation across the full product line has made TRUE successful and is a trademark of the TRUE heritage. TRUE's patented Heart Rate Control technology is just one of the remarkable ways we deliver simple and superior performance every user can enjoy, and most importantly, use to achieve personal health and fitness goals.

At the heart of our success is the relentless and systematic life testing of both our products and their components. We have dedicated employees who understand our philosophy is to deliver the best products in the world.

Our goal is to deliver the world's best premium equipment for our customers' health and fitness solutions.

TABLE OF CONTENTS

SAFETY..... 4

GENERAL CARE AND MAINTENANCE..... 7

MACHINE DIMENSIONS & WEIGHTS..... 8

WARNING LABELS..... 9

ASSEMBLY..... 10

PARTS DIAGRAMS..... 12

WARRANTY..... 15

SAFETY



FACILITY AND USER SAFETY PRECAUTIONS

1. Review and understand all of the warning labels affixed to this machine and on the facility safety sign.
2. Be certain that the machine operation is understood before it is used. Refer to the instructional Procedure Label affixed to the machine.
3. Make sure all users are properly trained on how to use this equipment. If this machine is being used in a commercial setting, end users may not have access to this Owners Manual. It is the responsibility of the facility to instruct users as to the proper usage of the equipment as well as making them aware of potential hazards. Maximum user weight is 300 lbs (136 kg).
4. Use each machine only for the intended exercise. Do not allow anyone to invent exercises not included on the Instructional Procedure Label or the Intended Use Label.
5. Do not modify the machine.
6. This equipment meets industry safety standards for stability when used for the intended exercise. Do not allow straps, resistance bands or other means to be attached to the framework of this machine to perform stretching or body weight exercises. This can result in machine instability and lead to serious crushing injuries.
7. Keep children away from this equipment. Adults should closely supervise use by teenagers.
8. It is recommended that users receive a thorough medical exam before commencing an exercise program. All medical issues should be reviewed to ensure that weight training will not aggravate pre-existing medical conditions.
9. If the machine appears damaged or inoperable, contact a facility staff member to place an "OUT OF ORDER, DO NOT USE" sign on the machine until it is repaired. Only use TRUE supplied replacement components to service this machine.
10. Instruct users not to wear loose or dangling clothes or have headphone wires hanging when using this equipment.
11. Do not attempt to free any jammed assemblies by yourself as this may cause injury.
12. On Plate Loaded and Free Weight machines:
 - 12a. Use of spotter(s). Instruct users to seek the advice of the facility staff as to the appropriate use of spotters when lifting. More than one spotter may be required depending upon the amount of weight being lifted.
 - 12b. Instruct users to load weight plates evenly and carefully (one side and then the other) to avoid tipping equipment and crushing injuries.
 - 12c. If the machine is equipped with safety stops or catches, inspect them and verify their proper operation before use and make sure they are securely in place before using or exiting the machine. Be certain members are instructed on how to operate and adjust all safety mechanisms.

- 12d. This equipment is designed for standard olympic size weight plates with a 50mm bore (1.9").
- 12e. Do not exceed the maximum weight capacity of the machine. Maximum plate size is 45 lbs. (25 kg.).
13. On Selectorized and Cable equipped machines:
- 13a. Do not allow users to perform any exercise by holding the end of the cable and/or the cable end fitting. Use only appropriate handles or attachments properly connected to the cable end.
- 13b. Do not high-pin or double-pin the weight stack. Do not allow the machine to be used if the top plate or weight stack is pinned in a raised position. Use an assistant and carefully return the machine to the proper position with the cap plate resting on the top weight. Inspect the entire length of the cable to ensure that it is properly seated in all of the pulley grooves.
- 13c. Do not allow the use of weight plates or dumbbells to be used as a means to add additional weight to the weight stacks. Use only the TRUE adder weight system specifically designed for the machine.



INSTALLATION SAFETY PRECAUTIONS

1. Read this Installation Manual entirely before assembling this equipment.
2. Verify that there is adequate space surrounding this piece of equipment for safe access and operation. Installation must meet ADA requirements for accessibility.
3. Install this piece of equipment on a solid level surface that does not deviate more than 1/8" over a 10' distance (or as defined and required by local building and architectural codes.
4. TRUE strongly recommends that all equipment be anchored to the floor to prevent movement and increase stability.
 - Due to the wide variation of flooring on which the unit can be installed, contact a qualified contractor to determine an appropriate fastening system for your floor.
 - Use 3/8" diameter hardware (10 mm) to anchor the machine. Anchors should have a minimum pull out force of 220 lbs (110 kgs) for each position.
 - When attaching the machine to the floor, if there is a gap between the machine foot and the floor, do not use the anchor to remove the gap as this can cause the machine frame to deform. Instead, place a shim between the bottom of the foot and the floor, then tighten the anchor.
 - Anchoring holes are provided on the feet of the frame. All anchoring locations must be used when anchoring the equipment to the floor.
5. DO NOT install any fitness equipment near a pool, hot tub or other damp locations. Corrosion caused by installation in these locations can lead to premature failure of components.
6. Be sure all hardware is tight before using this machine.

SAFETY



MAINTENANCE SAFETY PRECAUTIONS

1. Refer to Maintenance Schedule label on the machine as well as this manual for when to perform maintenance.
2. Check the function of your machine DAILY by verifying the following:
 - Inspect cables and end fittings for any signs of wear. Replace if worn, frayed or damaged with original TRUE replacement components.
 - Verify that all adjustments are possible and carried out with ease. Make sure that each adjustment pin inserts completely into each position without binding.
 - Verify that safety catches and stops are in proper working order and engaged.
 - Verify that the exercise is performed smoothly, free of noise and/or binding.
 - If equipped with a weight stack, verify that the proper weight selector pin is in place.
3. Check the function of your machine WEEKLY by verifying the following:
 - **Nuts, Bolts, and Fasteners:** Check tightness weekly. If any hardware has become loose, retighten and/or use Loctite™ Threadlocker 242.
 - **Frames and Lifting Arms:** Inspect weekly for integrity and function. Replace any component at first signs of wear. Use only TRUE supplied components.
4. Replace any warning label at first sign of wear. Labels and the Facility Safety Sign may be obtained from TRUE free of charge.

BOLT LENGTH MEASURING GUIDE

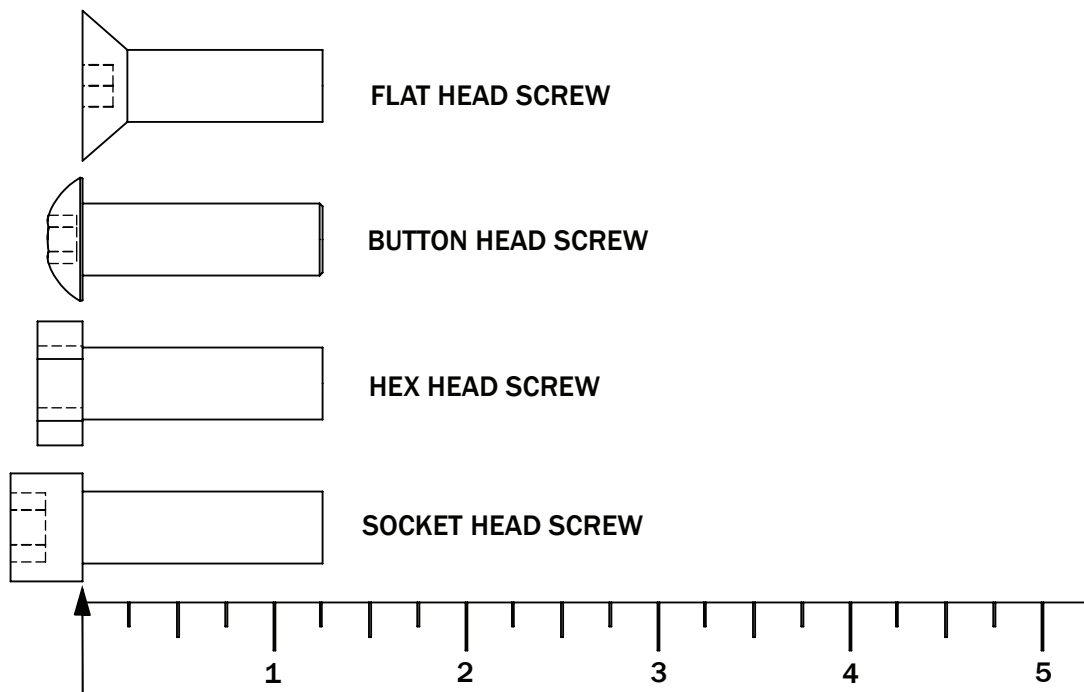

GENERAL CARE AND MAINTENANCE



IMPORTANT

Preventative maintenance is crucial to maintaining the function and safety of this equipment. Your facility must establish written guidelines for preventative maintenance and keep written or online records of the maintenance performed on these products. As a minimum, the items presented in the SAFETY section of this document and the items that follow here, should be included in your maintenance program.

1. **Cables:** Inspect end fittings daily for wear. Inspect the entire length of the cable weekly. Replace cables at the first sign of wear and on an annual basis. If the cable tension has been adjusted, be certain that the cable nut is tight.
2. **Nuts, Bolts, and Fasteners:** Check tightness weekly. If any hardware has become loose, retighten and/or use Loctite™ brand Threadlocker 242. Be sure all hardware is tight before using the machine.
3. **Safety Catches:** Inspect catches, stop rods and their associated fasteners weekly. Tighten any loose hardware and replace any components at first signs of wear.
4. **Frames:** Wipe all machines down with a damp cloth and dry completely each day. This includes painted parts, chrome parts and upholstered pads.
5. **Painted and chrome plated parts:** Use Simple Green or similar cleaner for light dirt and grime. Use Turtle Wax Polishing Compound or a good car polish to remove heavier dirt and grease as well as for polishing. DO NOT use solvents, lacquer thinner, acetone or finger nail polish remover. For scuffs and marks that are not removed by the above methods use a soft scrub cleanser. Make sure all parts are dry upon completion.
6. **Weight stack enclosures (shrouds):** Wipe down with a damp cloth as needed.
7. **Exercise instruction labels:** Clean with soap and water as needed.
8. **Guide rods:** Wipe all dirt and dust from the guide rods before applying a light application of Tri-Flow™ or other teflon spray lubricant. Spray the Tri-Flow™ on a rag and then wipe the guide rods with the rag. DO NOT use oil lubricants such as WD-40. Caution: Tri-Flow™ will stain carpet and clothing.
9. **Bronze bushings:** Check monthly for signs of wear and replace as needed.
10. **Linear Bearing Shafts:** Wipe any accumulation of dust or other contaminants from the shafts on a weekly basis. Apply a thin layer of a Teflon® (PTFE) grease on a weekly basis. TRUE recommends Magnalube® brand.
11. **When replacing any component, use only TRUE supplied parts.**
12. **Please refer to the General Maintenance Manual (part number: AM-GMM) for other important safety and maintenance information.**
13. **Be sure all hardware is tight before using the machine.**

Retain these instructions for future reference.

If you have any questions, do not hesitate to contact your TRUE dealer or TRUE Fitness Corp. at (800) 883-8783 or service@truefitness.com.

MACHINE DIMENSIONS & WEIGHTS

Carton Size:

84.25" X 38.75" X 7.75"

215 cm x 100 cm x 20 cm

Carton Weight (as shipped) = 173 lbs (79 kg.)

Assembled Weight (as shown) = 156 lbs (71kg.)

Maximum User Weight = 300 lbs. (136 kg.)

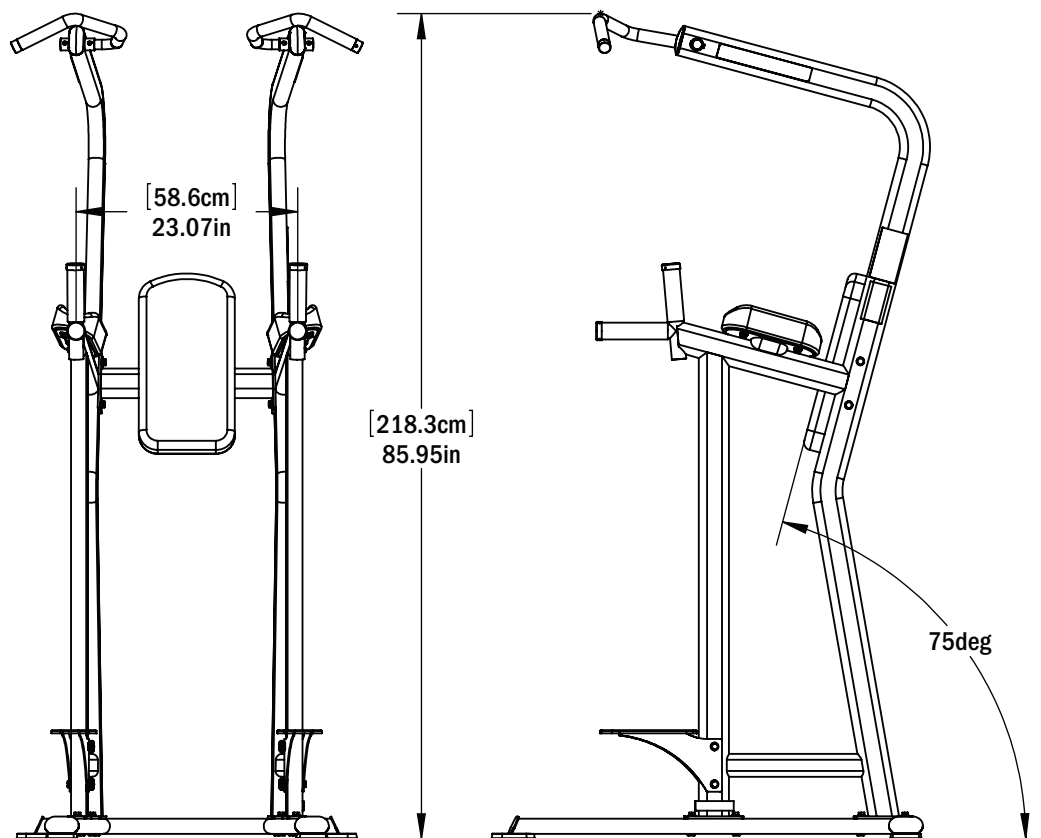
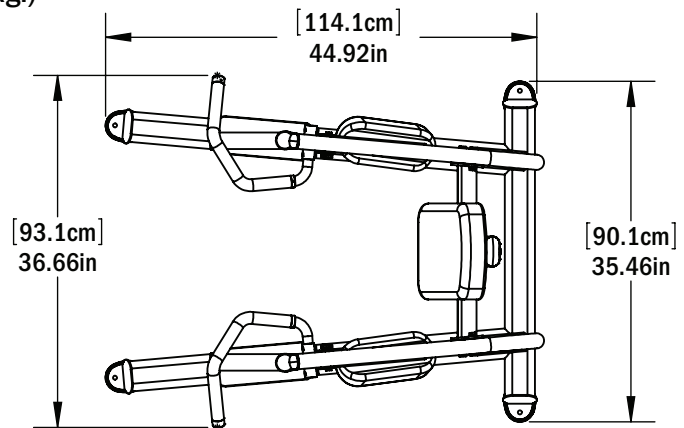

WARNING LABELS

The following are the warning labels required for this product. If any of these labels are missing or become damaged contact TRUE. Note: these labels are not to scale.

FS-23

Knee Raise/Dip/Chin

1. This multi-purpose bench is intended to support the user in an upright position while performing abdominal knee or leg raise exercises, pull ups, or triceps dips.
2. Use foot platforms to assist in getting into the proper exercise position.
3. Perform triceps dips and pull up exercises facing the back pad.
4. **DO NOT** use loose weights, bands, straps, or chains with this bench.
5. **DO NOT** exceed the maximum user weight of 300 pounds [136 kg].

LBL-PR-FS23

LBL-PR-FS23



WARNING

SERIOUS INJURY CAN OCCUR ON THIS EQUIPMENT. FOLLOW THESE PRECAUTIONS TO HELP AVOID INJURY.

1. **BEFORE USING:** Read and understand all of the warnings and labels and obtain instruction on the use of this machine.
2. Use only for the intended exercise. If you are unsure of the intended exercise seek instruction before using.
3. **DO NOT** attach straps or other devices to the frame. **DO NOT** use for stretching. **DO NOT** modify the machine.
4. Get a medical exam before beginning an exercise program.
5. **NEVER** allow children near this machine. Adults must supervise teenagers.
6. Keep body and clothing clear of all moving parts. **DO NOT** wear anything loose or dangling.
7. Inspect the machine before use. **DO NOT** use if it appears damaged. **DO NOT** try to fix. Notify staff immediately.
8. Inspect machine daily for loose, worn or damaged parts. Inspect stops and catch assemblies. Replace any part or label at first signs of wear. If you are in doubt about any part, **DO NOT** use the machine until the part is replaced. Use only Paramount supplied parts.
9. **DO NOT** remove this label. Replace if damaged.

ASTM F1749 LBL-WRN-0016

LBL-WRN-0016

ASSEMBLY

ITEM	PART NUMBER	DESCRIPTION	QTY.
1	C 955	PLASTIC CAP, 3/8" BOLT, BLACK	4
2	C 955A	BASE WASHER FOR PLASTIC CAP, 3/8" BOLT	4
3	C-446LP	HH SCREW, 3/8"-16, 1-1/4", LOCKING PATCH	16
4	C-449	HH SCREW, 3/8"-16, 2-1/4"	4
5	C-451	HH SCREW, 3/8"-16, 2-3/4"	2
6	C-749	WASHER, LOCK, 3/8", ZP	18
7	C-754C	WASHER, FLAT, 3/8" SAE, ZP	26
8	C-766A	LOCK NUT, 3/8"-16, NYL INS JAM NUT	4
9	D-896	PIN, 10MM X 36MM ROLL PIN, SLOTTED	4
10	FS23-BFR-00X	ASSY, BASE FRAME	1
11	FS23-CBR-00X	ASSY, PULL UP HANDLE, RIGHT (FACING MACHINE)	1
12	FS23-CBR-10X	ASSY, PULL UP HANDLE, LEFT (FACING MACHINE)	1
13	FS23-FPL-00X	FOOT PLATE ASSEMBLY	2
14	FS23-PFR-00X	BACK PAD FRAME	1
15	FS23-SFR-00X	ASSEMBLY, RIGHT SIDE FRAME, FACING MACHINE	1
16	FS23-SFR-10X	ASSEMBLY, LEFT SIDE FRAME, FACING MACHINE	1
17	PAD-XFW64-00X	BACK PAD	1
18	PAD-XFW64-10X	ELBOW PAD	2
19	SERIAL TAG	LABEL, SERIAL NUMBER	1

Required Tools:

- steel hammer
- 3/8" diameter pin punch
- (2) 9/16 wrenches or Sockets With Ratchet Handles

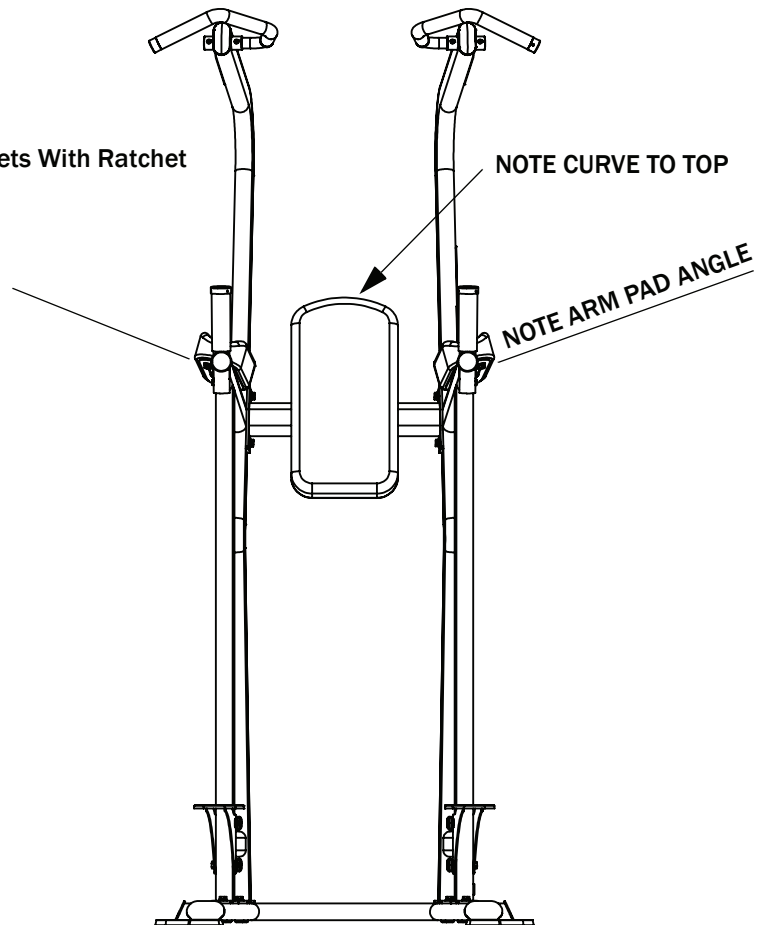

ASSEMBLY

Drive pins through frame tube and handle. Be sure they are even front to back.

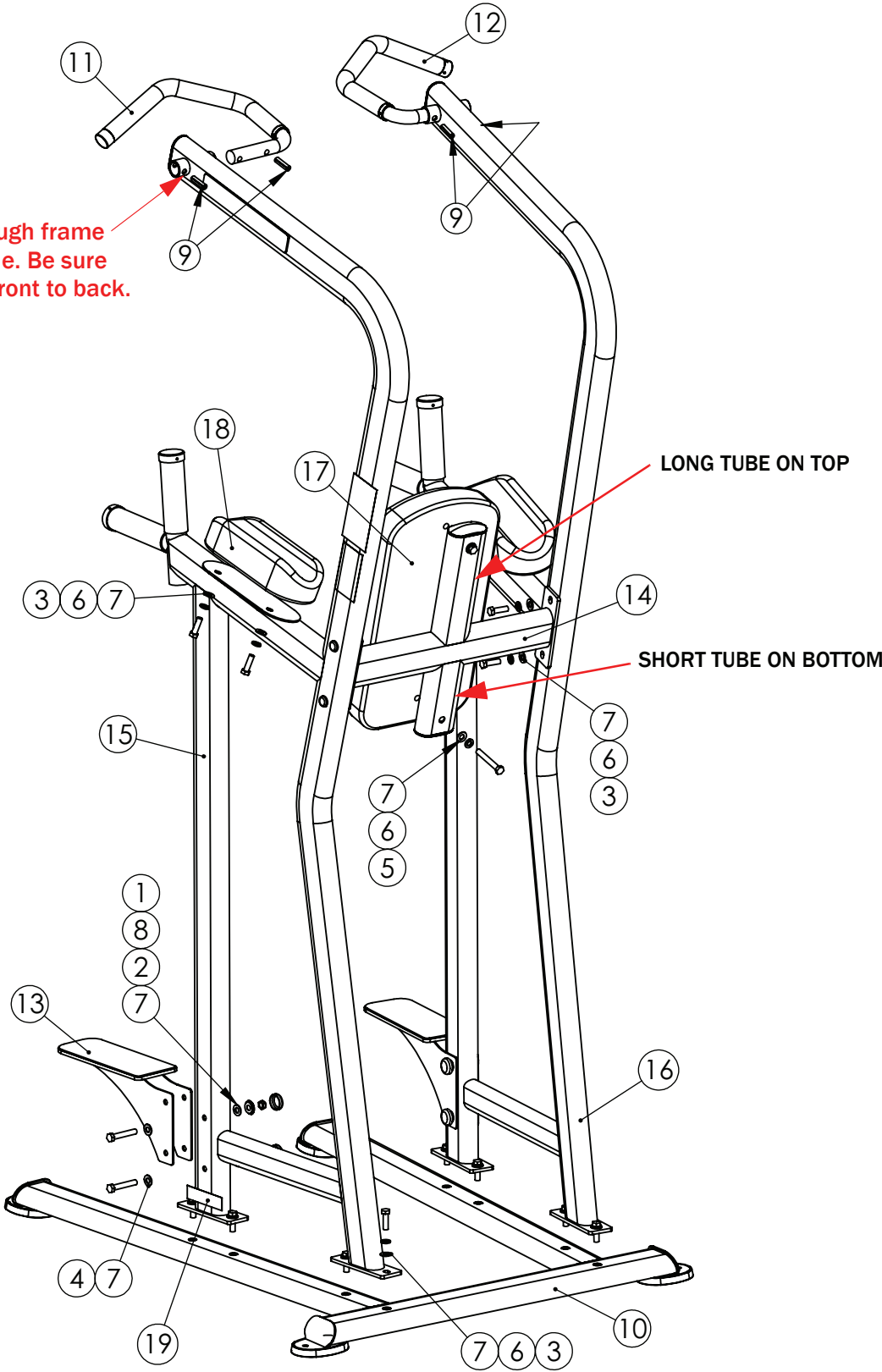

PARTS DIAGRAMS

FS23-SFR-00X, RIGHT SIDE FRAME ASSEMBLY			
ITEM	PART NUMBER	DESCRIPTION	QTY.
100	AXTSCS1800	END PLUG, 40X80 RACETRACK TUBE	1
101	B 441A	ALUMINUM END CAP, 1-1/2" ID.	2
102	FS23-GRP-01	HAND GRIP, VERTICAL	1
103	FS23-GRP-02	HAND GRIP, DIP HANDLE	1
104	FS23-SFR-00	WELDMENT, RIGHT SIDE FRAME, FACING MACHINE	1
105	LBL-LOG-0006	LOGO, "PARAMOUNT"	1
106	LBL-PR-FS23	LABEL, INTENDED USE	1
107	LBL-WRN-0016	LABEL, FS BENCHES GENERAL WARNING	1
FS23-SFR-10X, LEFT SIDE FRAME ASSEMBLY			
ITEM	PART NUMBER	DESCRIPTION	QTY.
110	AXTSCS1800	END PLUG, 40X80 RACETRACK TUBE	1
111	B 441A	ALUMINUM END CAP, 1-1/2" ID.	2
112	FS23-GRP-01	HAND GRIP, VERTICAL	1
113	FS23-GRP-02	HAND GRIP, DIP HANDLE	1
114	FS23-SFR-10	WELDMENT, LEFT SIDE FRAME, FACING MACHINE	1
115	LBL-LOG-0006	LOGO, "PARAMOUNT"	1
FS23-BFR-00X, BASE FRAME ASSEMBLY			
ITEM	PART NUMBER	DESCRIPTION	QTY.
120	FS23-BFR-00	WELDMENT, BASE FRAME	1
121	S 550B	RUBBER FOOT, WITH CENTER NIPPLE	4

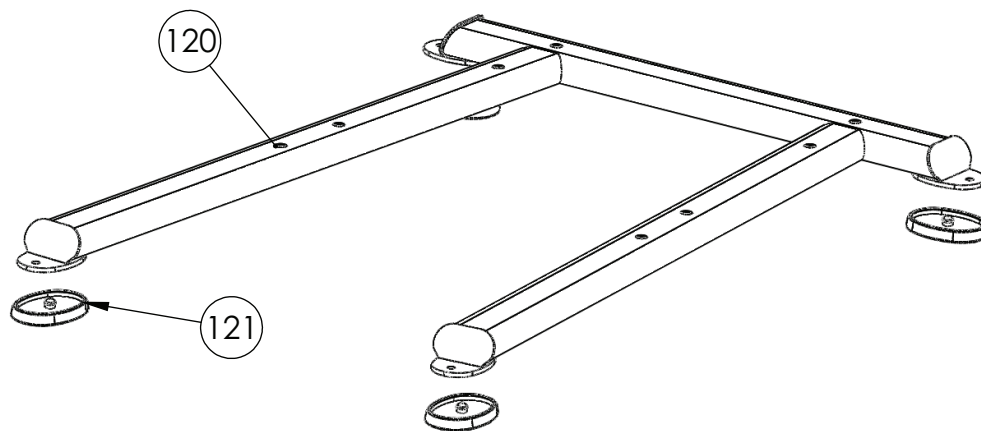

PARTS DIAGRAMS

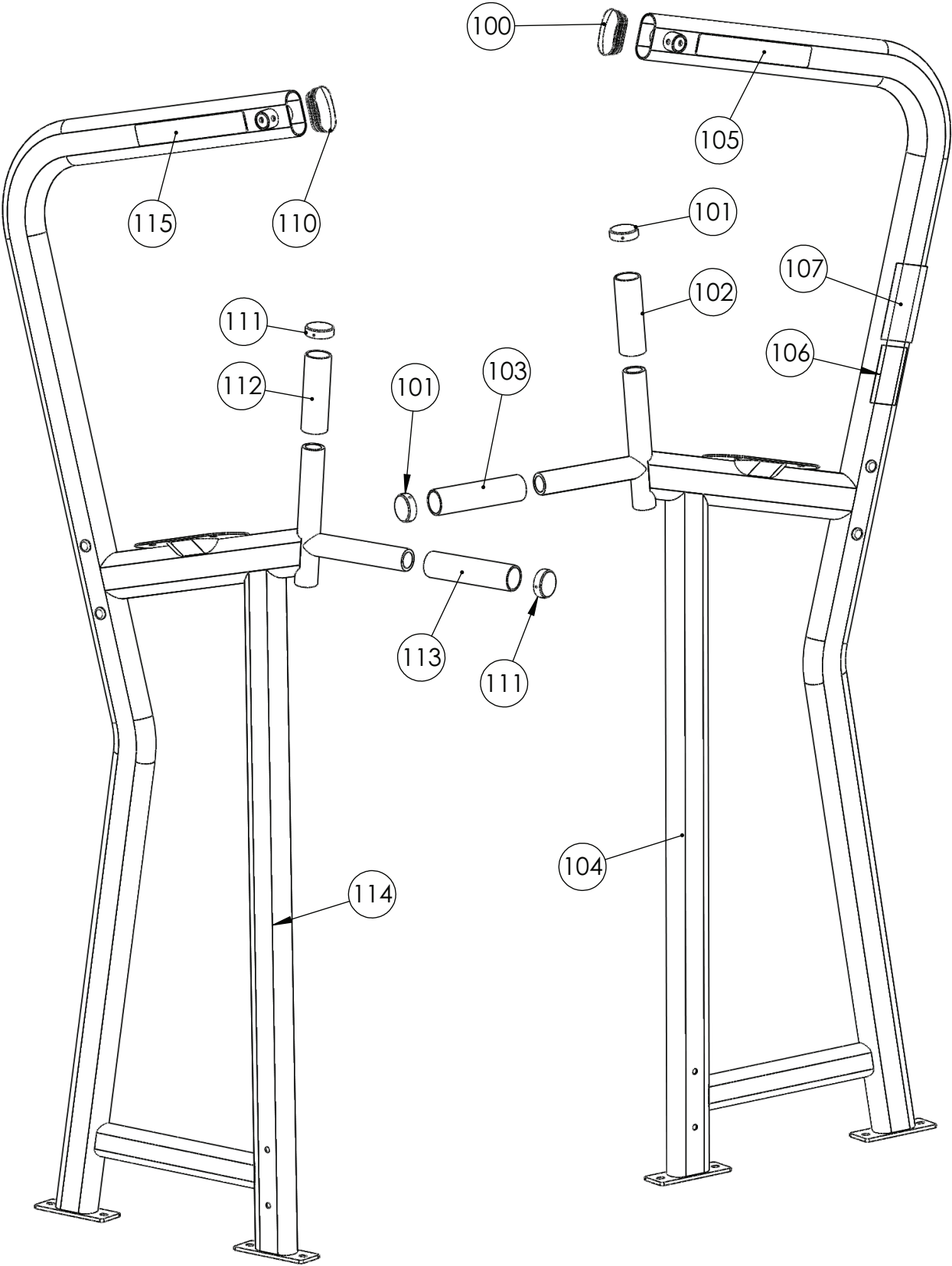

PARTS DIAGRAMS

FS23-CBR-00X, PULL UP HANDLE ASSEMBLY, RIGHT SIDE (FACING UNIT)			
ITEM	PART NUMBER	DESCRIPTION	QTY.
130	B 440	ALUMINUM SLEEVE, 1" ID	1
131	B 441	ALUMINUM END CAP, 1" ID	1
132	FS23-CBR-01	PULL UP BAR, RIGHT (FACING UNIT)	1
133	FS23-GRP-03	GRIP, PULL UP HANDLE	1
FS23-CBR-10X, PULL UP HANDLE ASSEMBLY, LEFT SIDE (FACING UNIT)			
ITEM	PART NUMBER	DESCRIPTION	QTY.
135	B 440	ALUMINUM SLEEVE, 1" ID	1
136	B 441	ALUMINUM END CAP, 1" ID	1
137	FS23-CBR-11	PULL UP BAR, LEFT (FACING UNIT)	1
138	FS23-GRP-03_	GRIP, PULL UP HANDLE	1

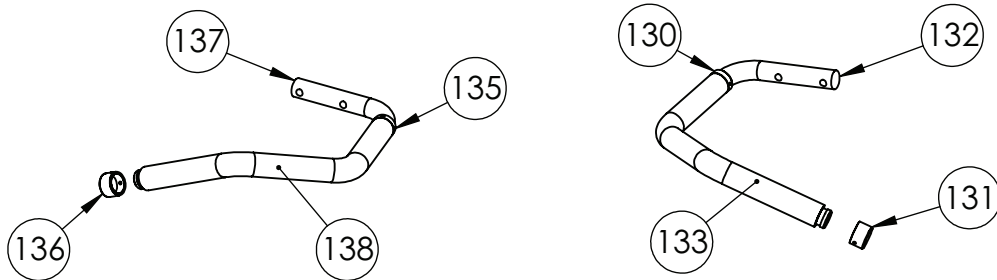

FS23-FPL-00X, FOOT PLATE ASSEMBLY			
ITEM	PART NUMBER	DESCRIPTION	QTY.
140	FS23-FPL-00	WELDMENT, FOOT PLATE	1
141	FS23-FPL-99	NON-SKID FOOT GRIP	1

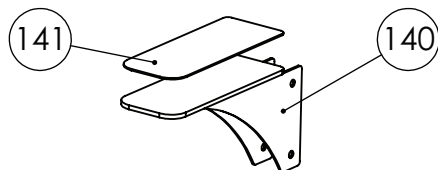

FS23-PFR-00X, BACK PAD FRAME ASSEMBLY			
ITEM	PART NUMBER	DESCRIPTION	QTY.
145	AXTSCS1800	END PLUG, 40X80 RACETRACK TUBE	2
146	FS23-PFR-00	WELDMENT, BACK PAD FRAME	1

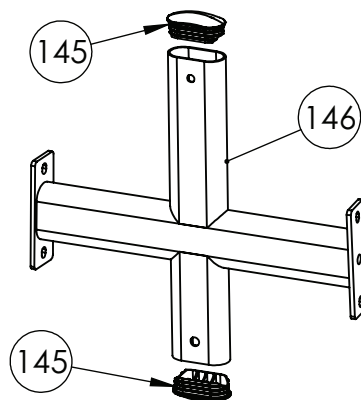

Save Time and Register Online!
 Activate Multiple Warranties at truefitness.com

All TRUE® Fitness products are distributed by TRUE and are warranted to the original registered product purchaser and the parts of the TRUE product (the “Product”) listed below, under normal use and service, shall be free of manufacturing defects in workmanship and materials only for the period of time beginning from the original date of purchase set forth below:

Frame*	10 Years
Parts	
Bearings, Bushings, and Weight Plates	5 Years
Guide Rods and Pulleys	5 Years
Cables and Belts	1 Year
Cosmetics, Coatings, Grips, and Upholstery	3 Months
Labor	
Frame	1 Year
Bearings, Bushings, Weight Plates	1 Year
Guide Rods and Pulleys	1 Year
Cables and Belts	1 Year
Cosmetics, Coatings, Grips, and Upholstery	3 Months

- NOTE: Warranty valid for USA and Canada only.
- NOTE: Failure to register this product will result in no servicing or authorization of parts to be shipped.
- NOTE: Buying after-market products from a 3rd party will result in voided warranty.
- NOTE: This product is intended for Commercial use. If this product will not be used in this particular setting, please contact TRUE as is warranty is void.

Frame: The frame is warranted for defects in material and workmanship for a 10 years. The frame is warranted for labor and freight (for parts shipped from TRUE) for one year from date of purchase. * This limited warranty on structural frame does not include paint or coatings.

Parts: The FS Strength Line’s mechanical parts are warranted for defects in material and workmanship for five years with one year labor warranty. Cables and belts are warranted for defects in material and workmanship for one year with one year labor warranty. This limited warranty does not cover damage or equipment failure resulting from or caused by improper assembly/installation, failure to follow instructions and warnings in owner’s manual, accident, misuse, abuse, unauthorized modification, or failure to provide reasonable and necessary maintenance.

Cosmetics: The FS Strength Line cosmetic parts, coatings, grips and upholstery are warranted for defects in material and workmanship for three months with labor warranty to match the parts warranty period. This limited warranty does not cover damage or equipment failure resulting from or caused by improper assembly/installation, failure to follow instructions and warnings in owner’s manual, accident, misuse, abuse, unauthorized modification, or failure to provide reasonable and necessary maintenance. This limited warranty will apply to, but may not be limited to, plastic covers, shrouds, caps, badges, overlays, paint, coatings, soft step inserts, and grips.

Labor: Labor is covered for a period of one year from the date of purchase unless otherwise expressed within this limited warranty as long as a TRUE authorized service provider performs the service. Service that requires over 50 miles of travel may be subject to additional charges. Reasonable and necessary maintenance guidelines can be found in the owner’s manual.

Claims Procedure: TRUE Limited Warranty service may be obtained by contacting the authorized TRUE dealer from whom the Product was purchased. If the dealer from whom the Product was purchased is no longer an authorized TRUE dealer, then TRUE Limited Warranty service may be obtained by contacting TRUE directly using the following contact information:

TRUE Fitness, Service Department
 865 Hoff Road, St. Louis, MO 63366
 1.800.883.8783
 Hours of operation 8:30am - 5:00 pm CST

Save Time and Register Online! Activate Multiple Warranties at truefitness.com

The above Limited Warranty is subject to and will be in accordance with the conditions set forth below:

- 1. THIS LIMITED WARRANTY GIVES YOU SPECIAL LEGAL RIGHTS AND YOU MAY ALSO HAVE OTHER RIGHTS, WHICH VARY FROM STATE TO STATE.**
2. This Limited Warranty can be processed only if the Warranty Registration Form is completed online, or if the attached form is filled in, signed by the original purchaser, and mailed to TRUE within 30 days of purchaser's receipt of this Product. The serial number must be intact on the Product for this Limited Warranty to be valid.
3. This Limited Warranty applies to the product only while the Product remains in the possession of the original purchaser and is not transferable
4. This Limited Warranty becomes VALID ONLY if the Product is initially assembled/installed by a TRUE authorized dealer/technician (if anyone other than a TRUE authorized dealer/technician initially assembles and installs the Product, this Limited Warranty will be void unless the written authorization of TRUE is first obtained).
5. This Limited Warranty does not cover damage or equipment failure resulting from or caused by improper assembly/installation, failure to follow instructions and warnings in owner's manual, accident, misuse, abuse, unauthorized modification, or failure to provide reasonable and necessary maintenance (as referenced in the owner's manual.)
6. This Limited Warranty applies only to the cost of repair or replacement of parts and does not include labor (beyond the above warranty period), transportation, service, return and freight charges associated therewith except as expressly specified herein.
7. This Limited Warranty shall not apply to: Service calls to correct installation of the equipment or instruction to owners on how to use the equipment; or any labor costs incurred beyond the applicable labor warranty period.
8. This Limited Warranty, which is given expressly and in lieu of all other express warranties, constitutes the only warranty made by TRUE.
- 9. ANY IMPLIED WARRANTY, INCLUDING WITHOUT LIMITATION THE WARRANTIES OF MERCHANTABILITY AND FITNESS FOR A PARTICULAR PURPOSE, IS LIMITED IN DURATION AND REMEDY TO THE TIME PERIOD COVERED BY THE LIMITED WARRANTY. SOME STATES DO NOT ALLOW LIMITATIONS ON HOW LONG AN IMPLIED WARRANTY LASTS, SO THE ABOVE LIMITATION MAY NOT APPLY TO YOU.**
- 10. THE REMEDIES DESCRIBED ABOVE ARE YOUR SOLE AND EXCLUSIVE REMEDIES AND TRUE'S ENTIRE LIABILITY**

FOR ANY BREACH OF THIS LIMITED WARRANTY. TRUE'S LIABILITY SHALL UNDER NO CIRCUMSTANCES EXCEED THE ACTUAL AMOUNT PAID BY YOU FOR THE PRODUCT, NOR SHALL TRUE UNDER ANY CIRCUMSTANCES BE LIABLE FOR ANY CONSEQUENTIAL, INCIDENTAL, SPECIAL, OR PUNITIVE DAMAGES OR LOSSES, WHETHER DIRECT OR INDIRECT. SOME STATES DO NOT ALLOW THE EXCLUSION OR LIMITATION OF INCIDENTAL OR CONSEQUENTIAL DAMAGES, SO THE ABOVE LIMITATION OR EXCLUSION MAY NOT APPLY TO YOU.

NOTE TO AUTHORIZED WARRANTY LABOR PROVIDERS:

Warranty labor reimbursement or warranty parts rights may not be transferred to, reassigned to, a third party without the express written consent of TRUE. Even jobbing out warranty labor requires TRUE's written approval.

FS STRENGTH LINE SERIAL NUMBER:

The FS-23 comes with one serial number on the base of the machine. Please write down your serial number below and keep for your records.

SERIAL NUMBER:

SAMPLE SERIAL NUMBER STICKER:

Keep this page for your records

Thank you for purchasing a TRUE product. To validate the TRUE product warranty the fast and easy way, please go on-line now to truefitness.com/support and register your product. The information you provide will never be distributed to any other individuals or agencies for any purpose. If you prefer to mail your warranty card, have the owner of the product complete the information below and return it to TRUE Fitness within 30 days from the date of equipment installation.

To mail your warranty information, please fill in the information below and mail to: Service Dept., TRUE Fitness, 865 Hoff Road, St. Louis, MO 63366 (or save postage and register online at truefitness.com)

Commercial Warranty Registration

**PLEASE PROVIDE YOUR SERIAL NUMBER BELOW.
REQUIRED FOR WARRANTY REGISTRATION:**

SERIAL NUMBER:

Model Type _____

Date of Purchase _____

Your Company Name _____

Contact First Name _____

Contact Last Name _____

Address _____

City _____ State _____ ZIP _____

Email Address _____ Website _____

Phone _____ Fax _____

1. Where did you first learn about TRUE?

- a. Dealer b. Website
 c. Advertisement d. Referral
 e. Current Customer f. Other _____

2. Why did you purchase a TRUE product?

- a. Design/Appearance b. Dealer Suggestion
 c. Price/Value d. Quality Construction
 e. Performance f. TRUE Reputation
 g. Other _____

3. Please indicate your type of facility:

- a. Apartment/Condo b. Corporate Fitness Center
 c. Municipality d. Health Club/Gym/Spa
 e. Hotel/Resort f. Military Base
 g. Student Rec Center h. Other

4. What other types of equipment does your company ly own?

- a. Treadmill Brand _____
 b. Bike Brand _____
 c. Elliptical Brand _____
 d. Free Weights/Gym Brand _____

5. How many people use your facility on a daily basis?

- a. <25 b. 25-75
 c. 76-150 d. 150+

6. Do you plan to purchase more fitness equipment in the next 6-12 months?

- Yes No

7. If you answered "yes" to question 6, what type do you plan to purchase?

- a. Treadmill b. Elliptical
 c. Stationary Bike d. Free Weights
 e. Gym f. Other _____

8. Would you recommend TRUE to other club owners?

- Yes No

9. You are a valued TRUE customer and your suggestions allow us to continually improve your experience. Is there anything else you would like us to know? Please explain: