



## AirRide



### **⚠ WARNING**

Do not operate this machine until you read and understand the complete Owner's Manual provided online here:

<http://www.octanefitness.com>



# TABLE OF CONTENTS

Important Safety Instructions	3	Operations	18
Safety Warning Labels / Serial Number	5	Adjustments	18
Specifications	6	Using the Machine	18
Before Assembly	6	Locking the Fan Assembly / Storage	19
Parts	7	Power Up / Idle Mode	19
Hardware	8	Manual Workout	19
Tools	8	Heart Rate Zones	20
Assembly	9	Pausing / Results Mode	20
Optional Power Adapter	14	Maintenance	22
Moving the Machine	15	Warranty (United States/Canada only)	23
Leveling the Machine	15		
Features	16		
Remote Heart Rate Monitor	17		
Auto-Calibration	17		

To validate warranty support, keep the original proof of purchase and record the following information:

**Serial Number** \_\_\_\_\_

**Date of Purchase** \_\_\_\_\_

To register your product warranty, contact your local distributor or Customer Support.

## Customer Support

If you have any questions regarding your product, please visit <https://support.octanefitness.com> where you will find answers to many common questions. Or, if you would like to speak to an Octane Fitness Customer Service specialist, please call:

- United States or Canada: 888.OCTANE4 or 763.757.2662.
- Latin America/Asia Pacific: 001-763-757-2662
- Europe/Middle East/Africa: 31-10-2662412

Live support is available Monday through Friday, 8:30 a.m. to 5 p.m. (United States Central Time).

TRUE Fitness  
865 Hoff Road  
St. Louis, MO 63366

© 2021 Octane Fitness, LLC. All rights reserved. Octane Fitness is a registered trademarks of Octane Fitness. Any use of these trademarks, without the express written consent of Octane Fitness, is forbidden.

ORIGINAL MANUAL - ENGLISH VERSION ONLY

When using an electrical appliance, basic precautions should always be followed, including the following:

 This icon means a potentially hazardous situation which, if not avoided, could result in death or serious injury.

Obey the following warnings:

 Read and understand all warnings on this machine.

**⚠ DANGER** Carefully read and understand the Assembly instructions. Read and understand the complete Manual. Keep the Manual for future reference.

**⚠ WARNING** To decrease the risk of burns, electric shock, or injury to persons, read and understand the complete Owner's Manual. Failure to follow these guidelines can cause a serious or possibly fatal electrical shock or other serious injury.

- Keep bystanders and children away from the product you are assembling at all times.
- Do not install the batteries into the machine until the time specified in the assembly manual. Do not connect the optional power supply to the machine until instructed to do so.
- The machine should never be left unattended when plugged in. Unplug from outlet when not in use, and before putting on or taking off parts.
- Before each use, examine this machine for loose parts or signs of wear. Do not use if found in this condition. Monitor the Pedals and Crank Arms closely. Contact your local distributor or Octane Fitness Customer Service for repair information.
- Not intended for use by persons with medical conditions where those conditions may impact the safe operation of the machine or pose a risk of injury to the user.
- Do not drop or put objects into any opening of the machine.
- Do not assemble this machine outdoors or in a wet or moist location.
- Make sure assembly is done in an appropriate work space away from foot traffic and exposure to bystanders.
- Some components of the machine can be heavy or awkward. Use a second person when doing the assembly steps involving these parts. Do not do steps that involve heavy lifting or awkward movements on your own.
- Set up this machine on a solid, level, horizontal surface.
- Do not try to change the design or functionality of this machine. This could compromise the safety of this machine and will void the warranty.
- If replacement parts are necessary use only genuine replacement parts and hardware supplied by Octane. Failure to use genuine replacement parts can cause a risk to users, keep the machine from operating correctly and void the warranty.
- Do not use or put the machine into service until the machine has been fully assembled and inspected for correct performance in accordance with the Manual.
- Use this machine only for its intended use as described in this manual. Do not use attachments not recommended by the manufacturer.
- Do all assembly steps in the sequence given. Incorrect assembly can lead to injury or incorrect function.
- SAVE THESE INSTRUCTIONS.

## Before using this equipment, obey the following warnings:

-  **Read and understand the complete Manual. Keep the Manual for future reference.**
- Read and understand all warnings on this machine. If at any time the Warning stickers become loose, unreadable or dislodged, contact your local distributor or Octane Fitness Customer Service for replacement stickers.**

**⚠ DANGER** To reduce the risk of electrical shock or unsupervised usage of the equipment, always unplug the power cord from the wall outlet and the machine before cleaning, maintaining or repairing the machine. Place the power cord in a secure location.

- Children must not be let on or near to this machine. Moving parts and other features of the machine can be dangerous to children.
- Not intended for use by anyone under 14 years of age.
- Consult a physician before you start an exercise program. Stop exercising if you feel pain or tightness in your chest, become short of breath, or feel faint. Contact your doctor before you use the machine again. Use the values calculated or measured by the machine's computer for reference purposes only.
- Before each use, examine this machine for damage to power cord, power receptacle, loose parts or signs of wear. Do not use if found in this condition. Monitor the Pedals and Crank Arms closely. Contact your local distributor or Octane Fitness Customer Service for repair information.
- Maximum user weight limit: 159 kg (350 lbs.). Do not use if you are over this weight.
- Do not wear loose clothing or jewelry. This machine contains moving parts. Do not put fingers or other objects into moving parts of the exercise equipment.
- Always wear rubber soled athletic shoes when you use this machine. Do not use the machine with bare feet or only wearing socks.
- Set up and operate this machine on a solid, level, horizontal surface.
- Do not step off the machine until the Pedals have fully stopped.
- Make the Pedals stable before you step on them. Use caution when you step on and off the machine.
- Disconnect all power before servicing this machine.
- Do not operate this machine outdoors or in moist or wet locations.
- Keep at least 0.6 m (24") on each side of the machine clear. This is the recommended safe distance for access and passage around and emergency dismounts from the machine. Keep third parties out of this space when machine is in use.
- Do not over exert yourself during exercise. Operate the machine in the manner described in this manual.
- Perform all regular and periodic maintenance procedures recommended in the Owner's Manual.
- Do not drop or put objects into any opening of the machine.
- Correctly adjust and safely engage all Positional Adjustment Devices. Make sure that the Adjustment Devices do not hit the user.
- Keep the Pedals clean and dry.
- Exercise on this machine requires coordination and balance. Be sure to anticipate that changes in speed and resistance level can occur during workouts, and be attentive in order to avoid loss of balance and possible injury.
- A machine should never be left unattended when plugged in. Unplug from outlet when not in use, and before putting on or taking off parts.
- Keep batteries away from heat source and hot surfaces.
- Do not mix old and new batteries.
- Do not mix alkaline, standard (carbon-zinc), or rechargeable (Ni-Cd, Ni-MH, etc) batteries.
- Do not try to charge non-rechargeable batteries. Remove exhausted batteries and dispose of them safely.
- Remove rechargeable batteries from the machine before recharging them.
- Do not short-circuit the supply terminals on the batteries.
- For safe storage of the machine, remove the batteries and install the Transport and Immobilization Strap to secure the Resistance Fan. Place the machine in a secure location away from children and pets.

## SAFETY WARNING LABELS AND SERIAL NUMBER

- When the machine is put in a Studio/Institutional environment, it can only be used in areas where access and control of the machine are managed and supervised by approved staff. The degree of supervision and oversight depends among other things on the specific setting in which the machine is placed, security of that environment, and familiarity of the users with the equipment. Because others will have used the machine previously, make sure the seat, pedals and handlebars are correctly adjusted, tightened and secured.
- Since this machine operates with a fixed gear, do not back, or reverse, pedal. Doing so may loosen the Pedals, which could result in damage to the machine and/or injury to the user. Never operate this machine with loose Pedals.
- This appliance is not intended for use by persons (including children) with reduced physical, sensory or mental capabilities, or lack of experience and knowledge, unless they have been given supervision or instruction concerning use of the appliance by a person responsible for their safety.
- This bike cannot stop the Pedals independently of the Resistance Fan. Reduce the pace to slow the Resistance Fan and Pedals to a stop. Do not dismount the bike until the Pedals have come to a complete stop. Be aware that the moving Pedals can strike the backs of the legs.
- Children should be supervised to ensure that they do not play with the appliance.

### Safety Warning Labels and Serial Number

Serial number

Product specification

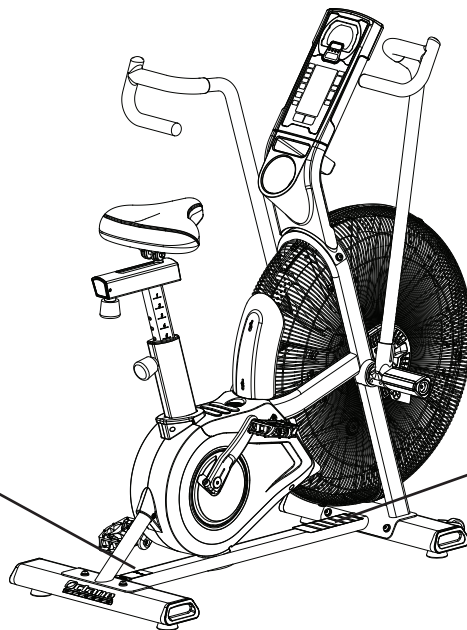

### FCC Compliance

- ⚠ Changes or modifications to this unit not expressly approved by the party responsible for compliance could void the user's authority to operate the equipment.

The power supply complies with part 15 of the FCC rules. Operation is subject to the following two conditions: (1) This device may not cause harmful interference, and (2) this device must accept any interference received, including interference that may cause undesired operation.

Note: This power supply has been tested and found to comply with the limits for a Class B digital device, pursuant to Part 15 of the FCC Rules. These limits are designed to provide reasonable protection against harmful interference in a residential installation. This equipment generates, uses and can radiate radio frequency energy and, if not installed and used in accordance with the instructions, may cause harmful interference to radio communications.

However, there is no guarantee that interference will not occur in a particular installation. If this equipment does cause harmful interference to radio or television reception, which can be determined by turning the equipment off and on, the user is encouraged to try to correct the interference by one or more of the following measures:

- Reorient or relocate the receiving antenna.
- Increase the separation between the equipment and receiver.
- Connect the equipment into an outlet on a circuit different from that to which the receiver is connected.
- Consult the dealer or an experienced radio/TV technician for help.

# SPECIFICATIONS

- Maximum User Weight:** 159 kg (350 lbs.)  
**Total Surface Area (footprint) of equipment:** 9059 cm<sup>2</sup> (1405 in<sup>2</sup>)  
**Machine Weight:** 51.3 kg (113 lbs.)  
**Power Requirements:** 2 D Batteries (LR20)  
Operating Voltage: 3V DC  
Optional AC Power Adapter: 100V - 240V AC, 50-60Hz, 1500mA

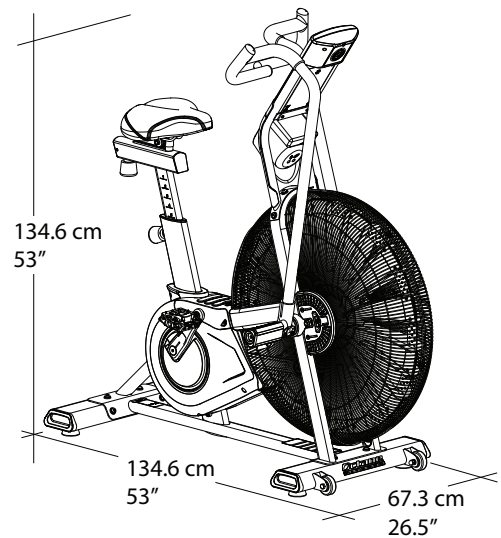

DO NOT dispose of this product as refuse. This product is to be recycled. For proper disposal of this product, please follow the prescribed methods at an approved waste center.

## Before Assembly

Select the area where you are going to set up and operate your machine. For safe operation, the location must be on a hard, level surface. Allow a workout area of a minimum 1.9 m (74.5") x 2.6 m (101").

### Basic Assembly Tips

Follow these basic points when you assemble your machine:

- Read and understand the "Important Safety Instructions" before assembly.
- Collect all the pieces necessary for each assembly step.
- Using the recommended wrenches, turn the bolts and nuts to the right (clockwise) to tighten, and the left (counterclockwise) to loosen, unless instructed otherwise.
- When attaching 2 pieces, lightly lift and look through the bolt holes to help insert the bolt through the holes.
- The assembly requires 2 people.

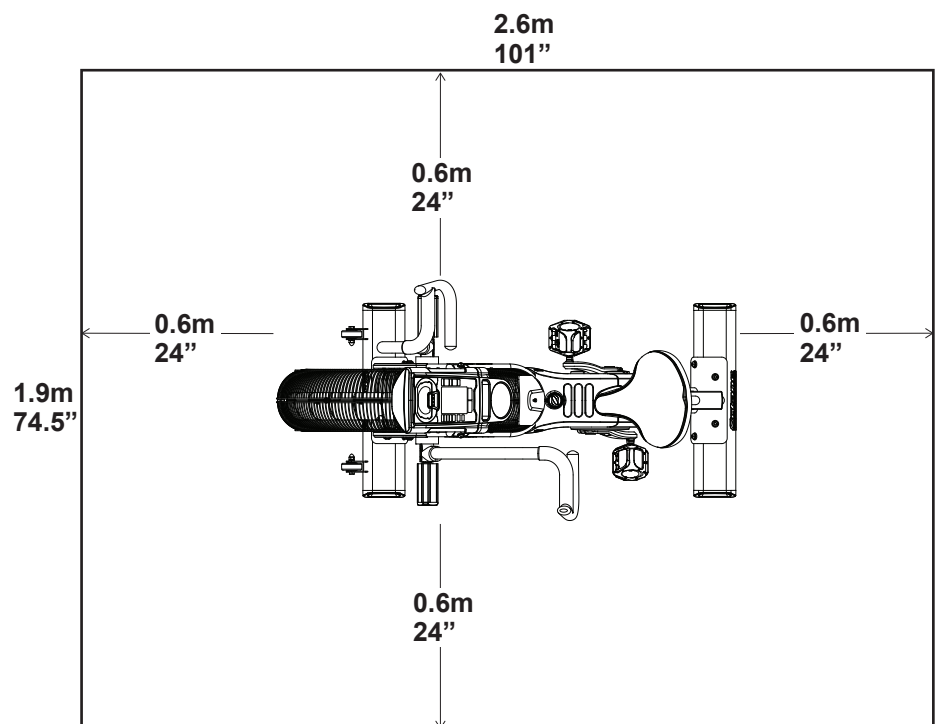

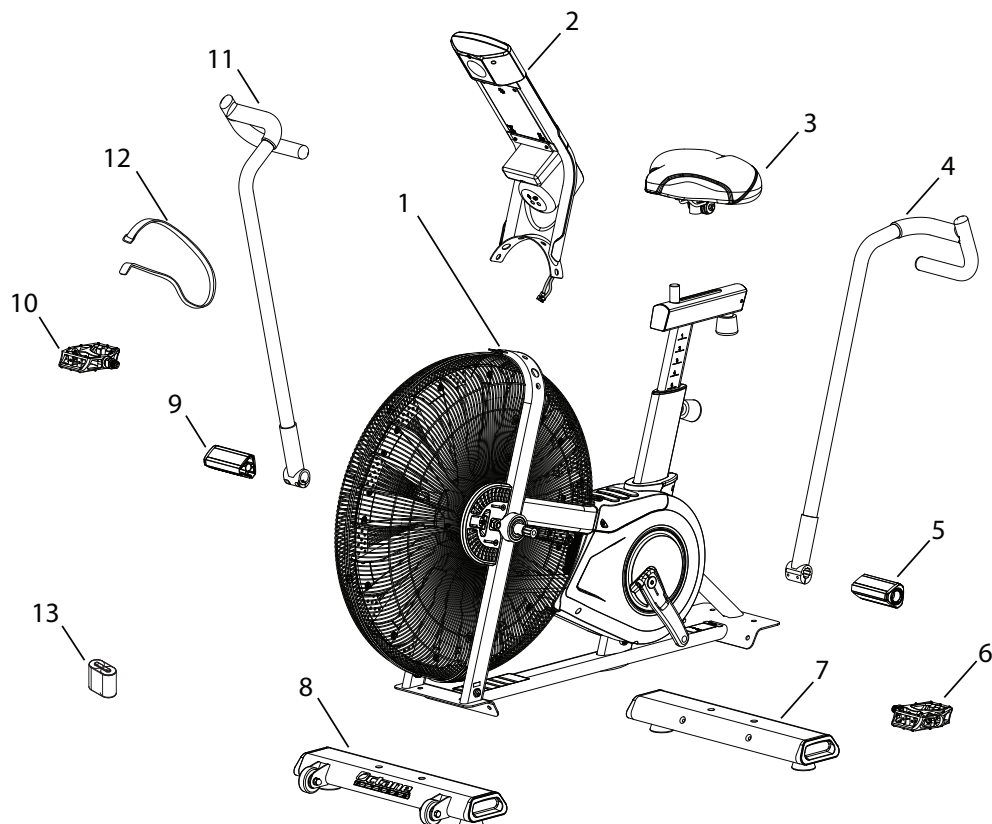

A decal has been applied to all right (“ R ”) and left (“ L ”) parts to assist with assembly.

Item	Qty	Description	Item	Qty	Description
1	1	Frame Assembly	8	1	Stabilizer, Front
2	1	Console / Mast Assembly	9	1	Foot Peg, Right
3	1	Seat	10	1	Pedal, Right
4	1	Handlebar, Left	11	1	Handlebar, Right
5	1	Foot Peg, Left	12	1	Strap, Transport and Immobilization
6	1	Pedal, Left	13	2	Batteries, D size (LR20)
7	1	Stabilizer, Rear			

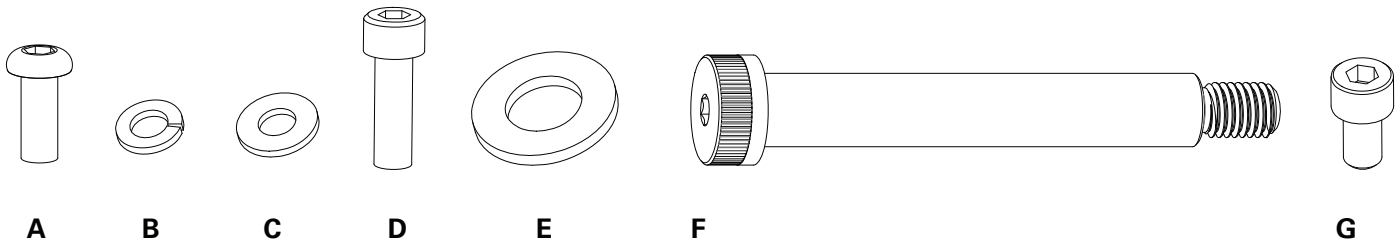

Item	Qty	Description	Item	Qty	Description
A	12	Button Head Hex Screw, M8x16	E	2	Flat Washer, M16
B	13	Lock Washer, M8	F	2	Shoulder Screw, M12x100
C	12	Flat Washer, M8	G	1	Socket Head Cap Screw, M8x14
D	4	Socket Head Cap Screw, M8x25			

**Note:** Select pieces of Hardware have been provided as spares on the Hardware Card. Be aware that there may be remaining Hardware after the proper assembly of your machine.

## Tools

### Included



6 mm



#2  
6 mm



13 / 15 mm



## 1. Attach Stabilizers to Frame Assembly

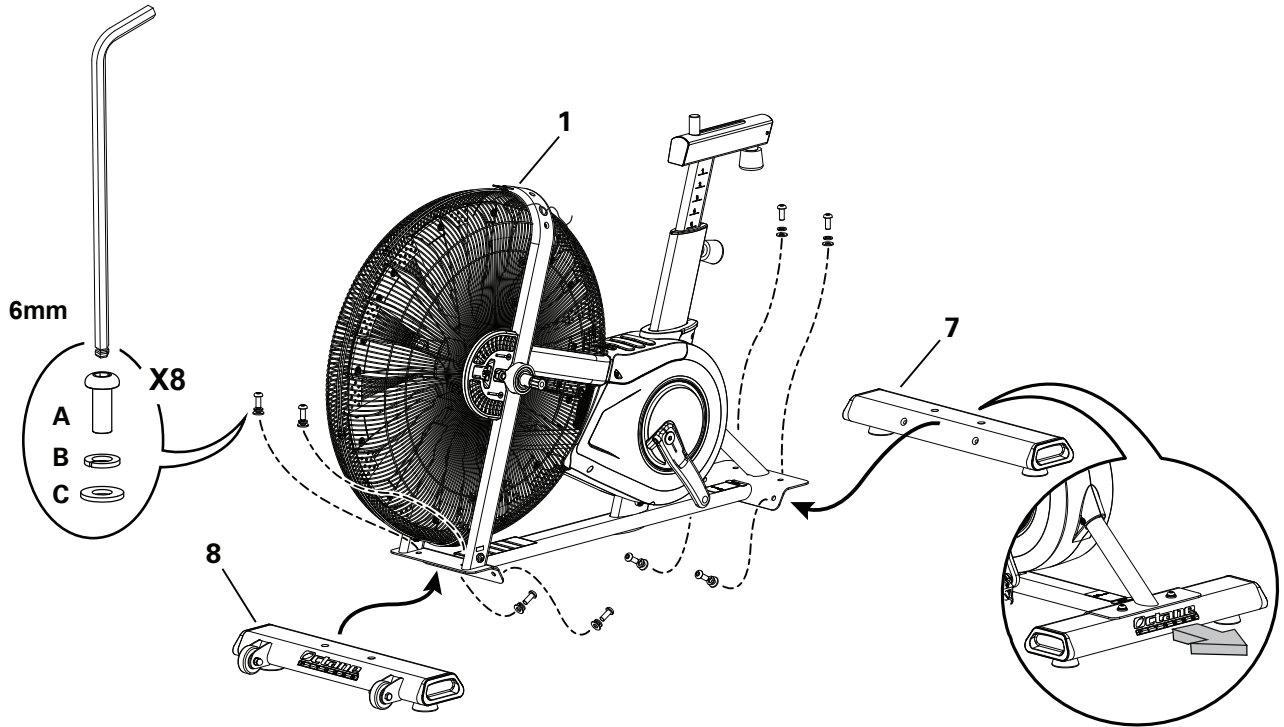

## 2. Attach Pedals to Frame Assembly

**⚠** If the threads strip due to improper installation, then the Pedals can disengage from the bike and/or break while under usage, which can result in serious injury to the user.

**Note:** The Left Pedal is reverse-threaded. Be sure to attach Pedals on the proper side of the Bike. Orientation is based from a seated position on the bike. The Left Pedal has an “L”, the Right Pedal an “R”.

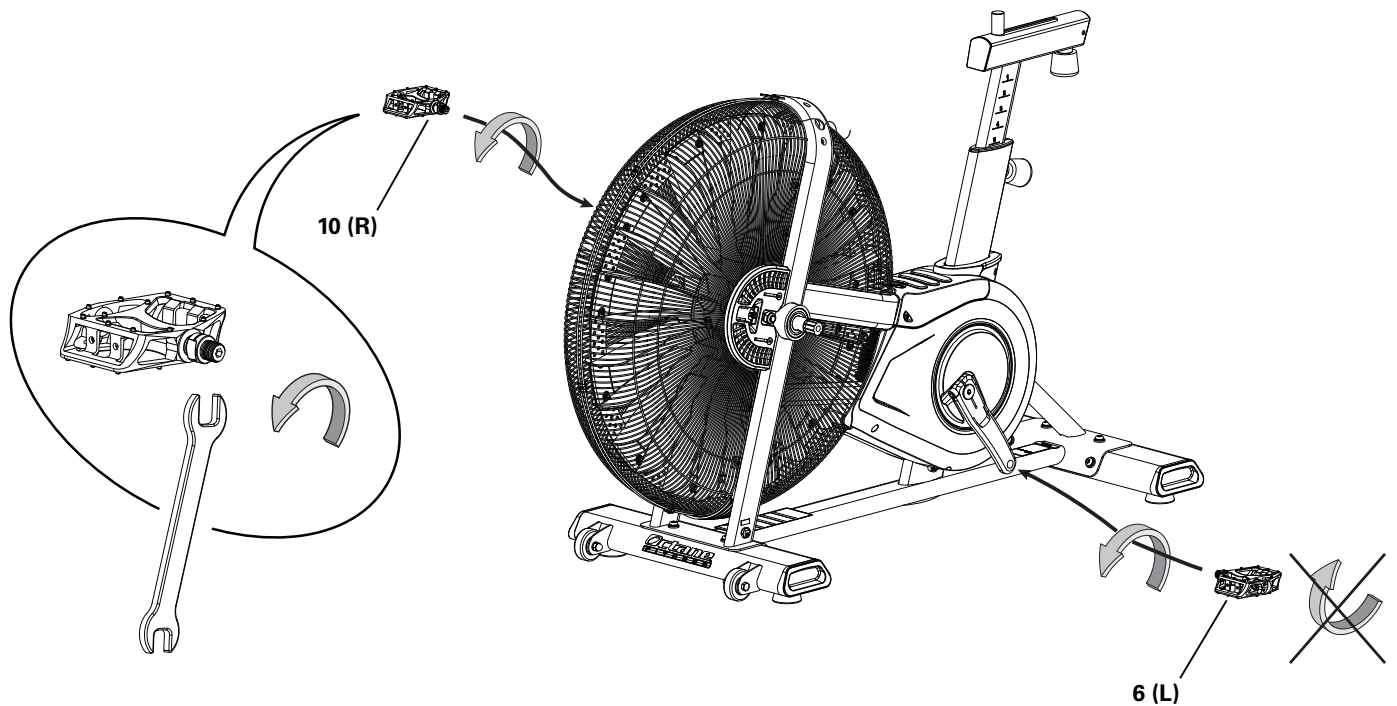

### 3. Connect Cables and Attach the Console/Mast Assembly to Frame Assembly

**NOTICE:** Do not crimp the cables.

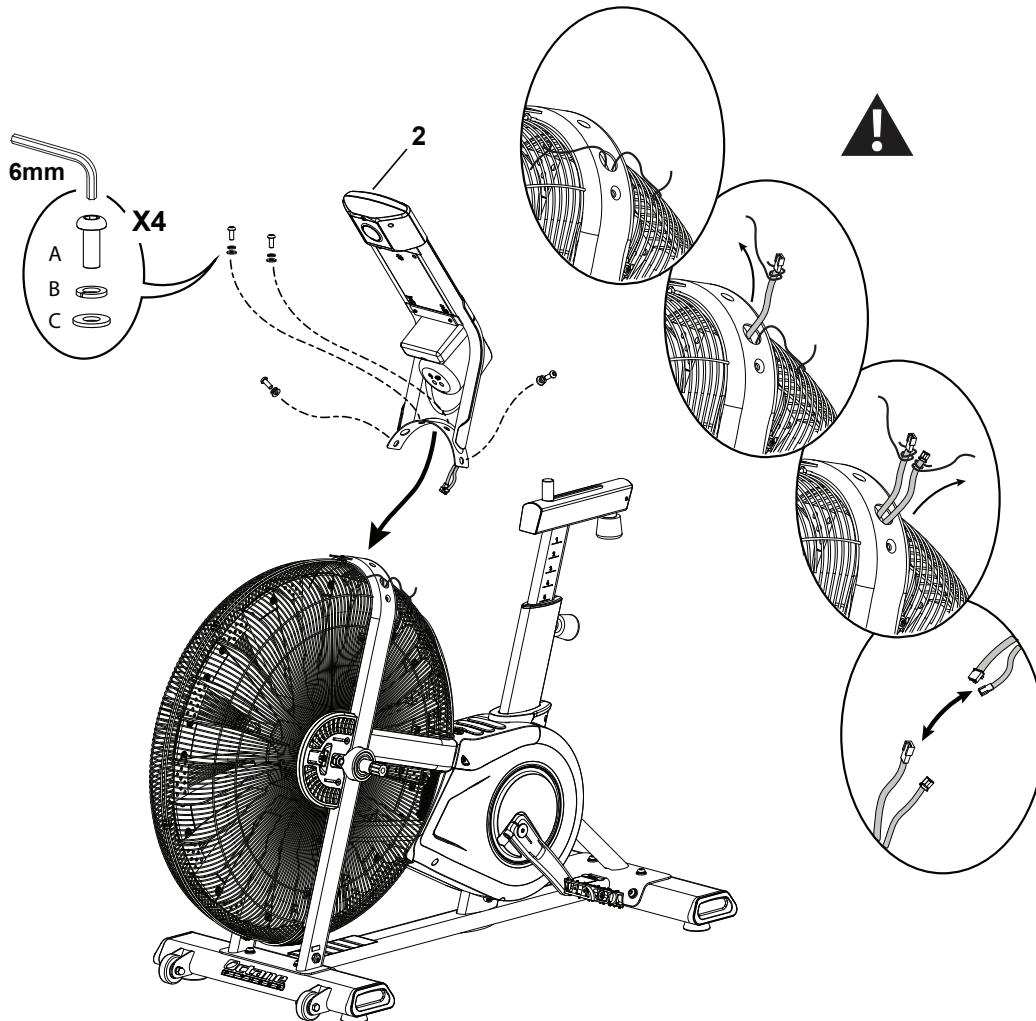

#### 4. Attach Handlebar Arms to Frame Assembly

**NOTICE:** Remove tag from the Handlebar Arm. Align the open curve (a) on the handlebar with the smooth curve (1a) on the pivot shaft and make sure the indents (b) are exactly aligned. Carefully push the handlebar onto the shaft. Do not force or hammer into position. Gently rock the handlebar forward and backward to make sure it is fully seated on the shaft.

**!** Fully tighten hardware. Make sure the Handlebar Arms are secure before you exercise. If a torque wrench is available, tighten bolts to 40 N·m.

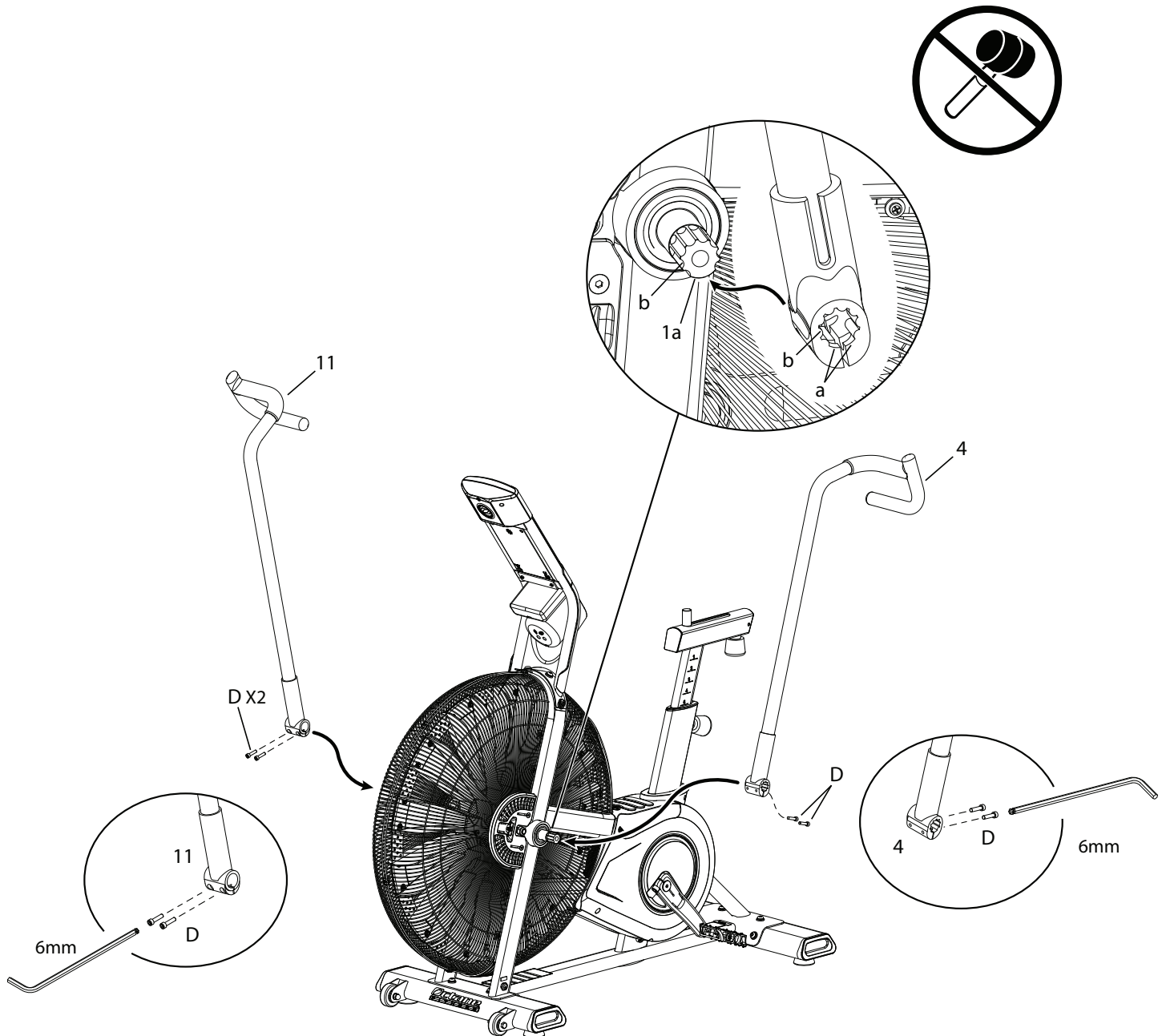

## 5. Assemble Foot Pegs and Hardware, and Attach Foot Pegs to Frame Assembly

**NOTICE:** Push the Shoulder Screw (F) completely through the Foot Peg, and press the Washer (E) tightly onto the end of the Foot Peg. Be sure the Washer does not touch the bolt threads (F1). Do not let the Washer fall off the Foot Peg during installation.

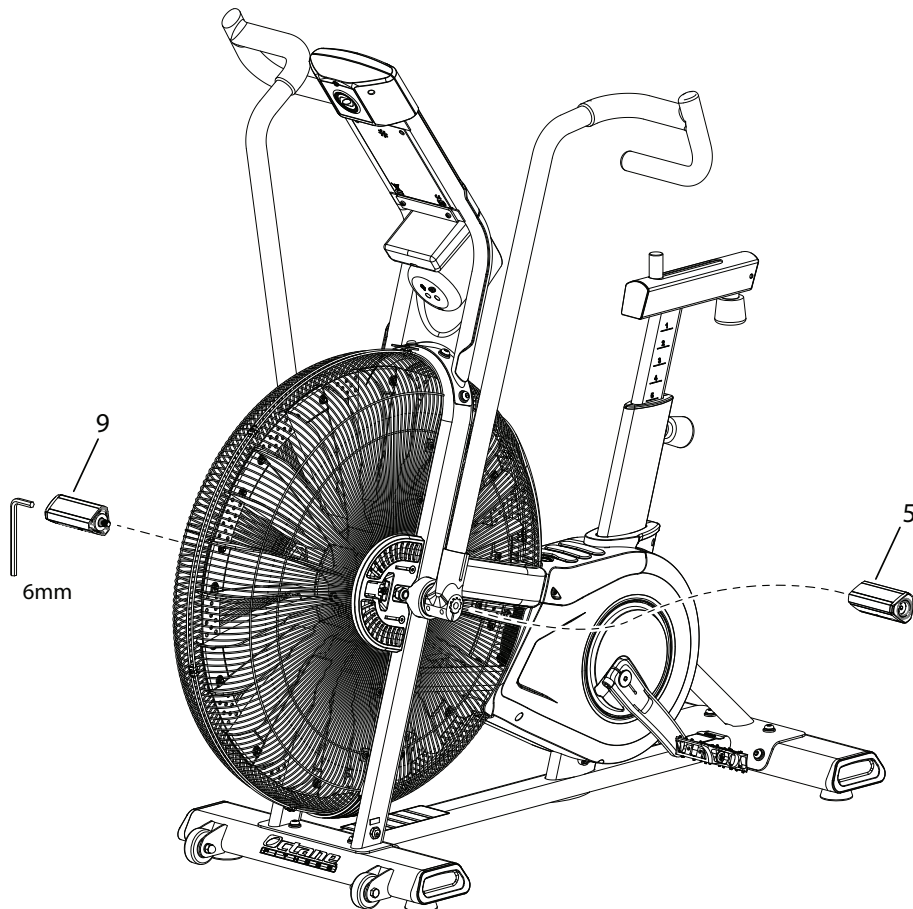
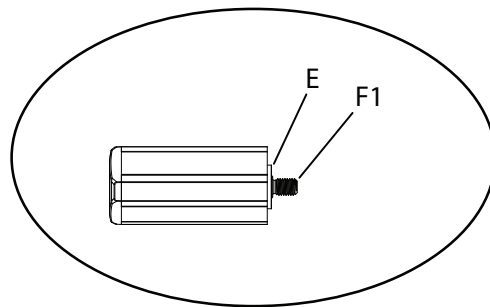
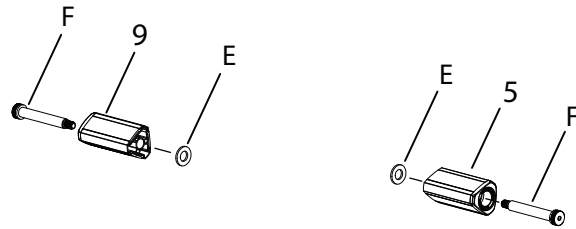

## 6. Attach Seat to Seat Post

**NOTICE:** Be sure the Seat is straight. Align the holes in the front of Seat bracket (3a) and the post (1c), and install the hardware. Fully tighten the screw. Tighten both nuts (3b) on the Seat bracket to hold the Seat in position.

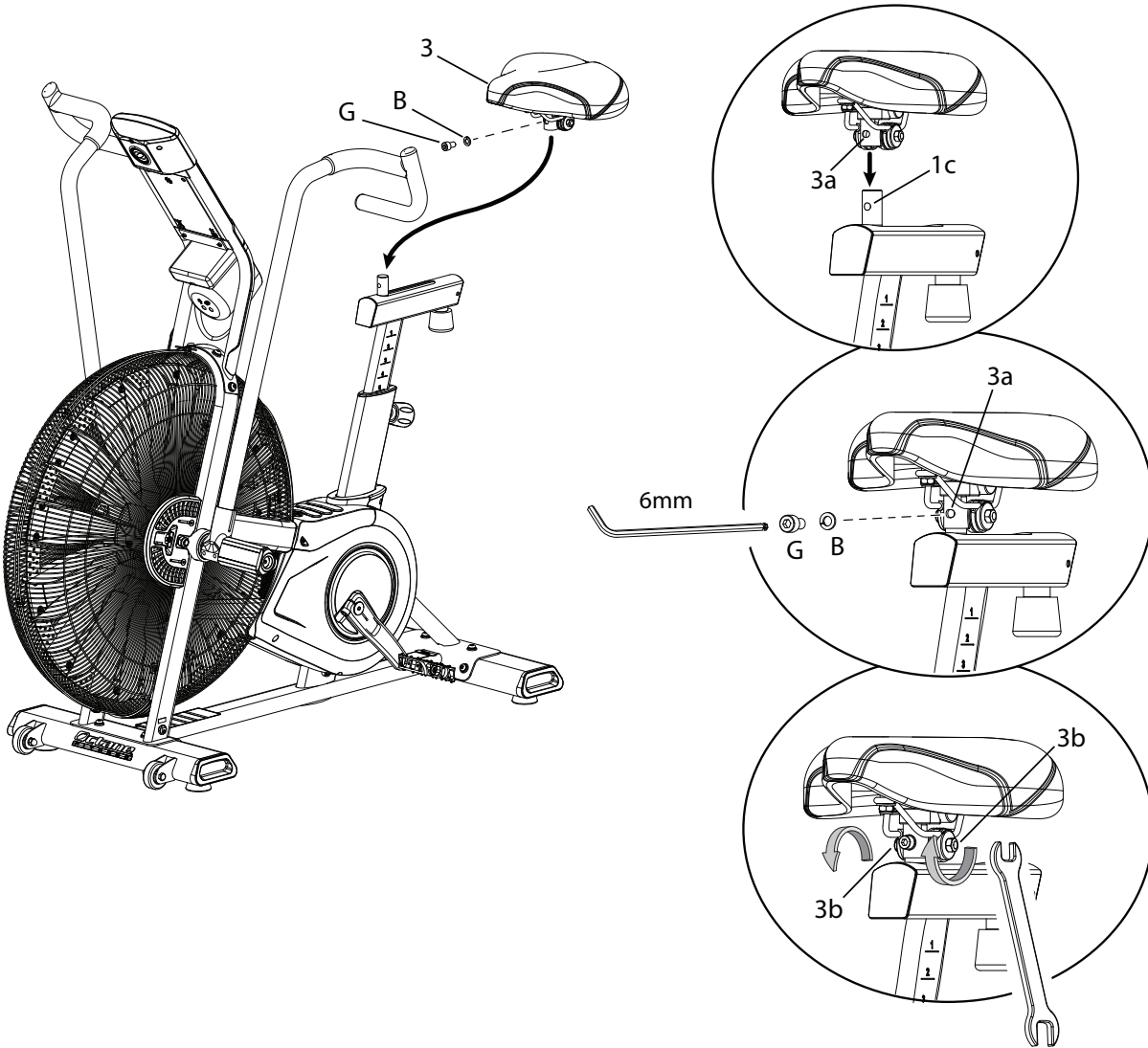

## 7. Install Batteries in Console

**Note:** To open the battery bay, loosen the preinstalled screw in the cover. The console uses D size batteries (LR20). Make sure that the batteries point in the direction of the +/- indicators in the battery bay. If you use rechargeable batteries, the optional power adapter will not recharge the batteries.

**⚠ Do not mix old and new batteries.**

**Do not mix alkaline, standard (carbon-zinc), or rechargeable (Ni-Cd, Ni-MH, etc) batteries.**

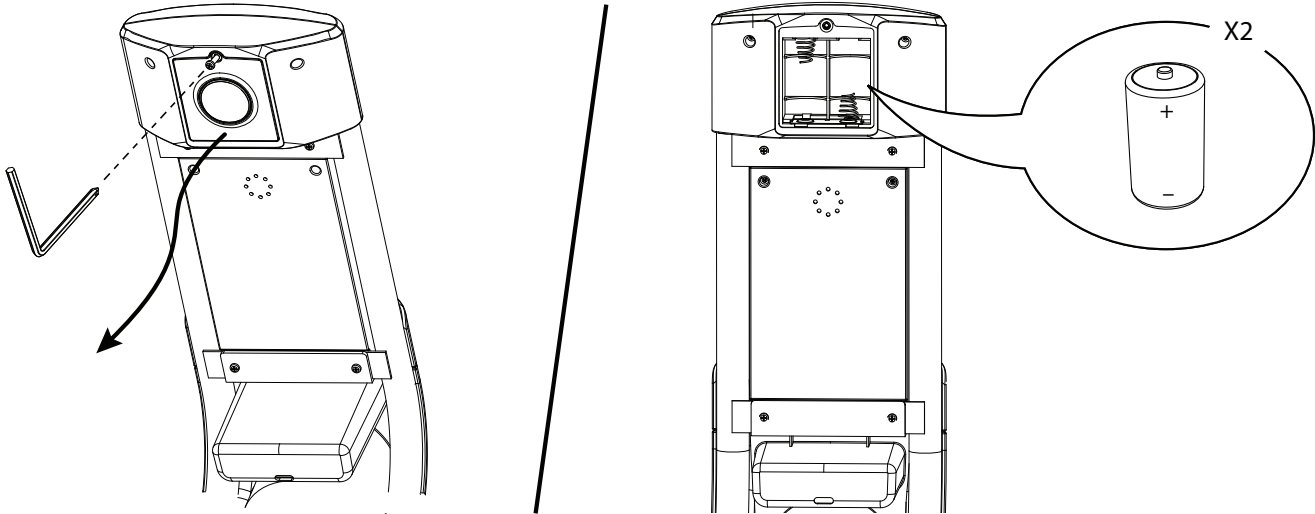

## Optional Power Adapter

The console for your machine can operate on battery power or AC power. For AC power, it is necessary to order the optional Power Adapter. If batteries and the Power Adapter are installed, the console will use the Power Adapter to operate.

**Note:** If you use rechargeable batteries, the optional Power Adapter will not recharge the batteries.

After the machine is fully assembled, connect the Power Adapter to the Power Connector and the wall outlet.

**NOTICE:** If you use a power adapter for your machine, make sure that the cord stays clear of the path of the pedals.

**NOTICE:** It is recommended to remove batteries when they are not used, to avoid damage from battery corrosion.

In the United States—to order the optional Power Adapter, go to: [www.octanefitness.com](http://www.octanefitness.com)

Or call 1 (888) OCTANE4 (628-2634).

Outside the United States— contact your local distributor.

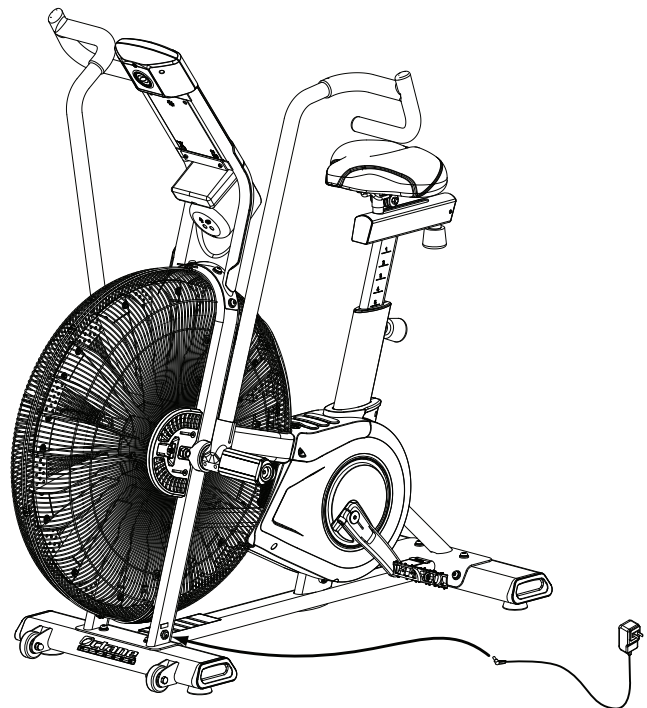

## 8. Final Inspection

Inspect your machine to ensure that all hardware is tight and components are properly assembled.

Be sure to record the serial number in the field provided at the front of this manual.

**⚠ Do not use or put the machine into service until the machine has been fully assembled and inspected for correct performance in accordance with the Owner's Manual.**

## Moving the Machine

**⚠** The machine may be moved by one or more persons depending on their physical abilities and capacities. Make sure that you and others are all physically fit and able to move the machine safely. Use proper safety precautions and lifting techniques.

1. Secure the Crank Arm to the Seat Post with the Transport and Immobilization Strap (T).
2. Use the Rear Stabilizer to carefully lift the machine onto the transport rollers.

**Note:** Be sure to keep the fan assembly clear of the floor.

3. Push the machine into position.
4. Carefully lower the machine into position.

**NOTICE:** Be careful when you move the machine. Abrupt motions can affect the computer operation.

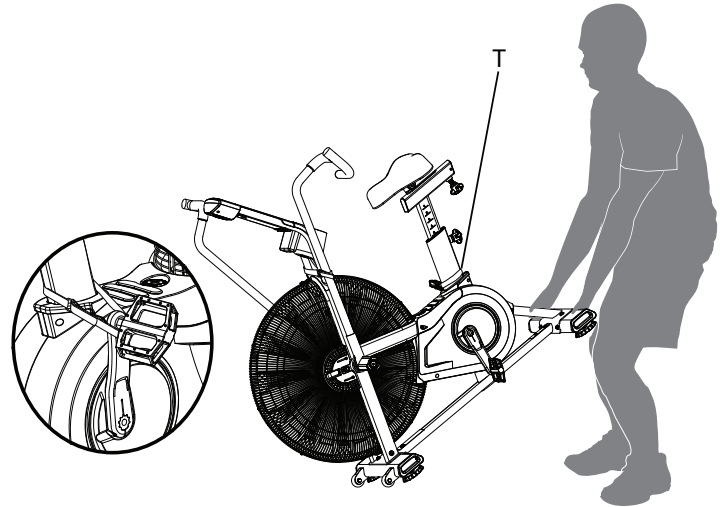

## Leveling the Machine

The machine needs to be leveled if your workout area is uneven. Levelers are on each side of the Stabilizers. To adjust:

1. Place the machine in your workout area.
2. Turn the stabilizer feet to adjust until they are evenly balanced and in contact with the floor.

**⚠** Do not adjust the levelers to such a height that they detach or unscrew from the machine. Injury to you or damage to the machine can occur.

Make sure the machine is level and stable before you exercise.

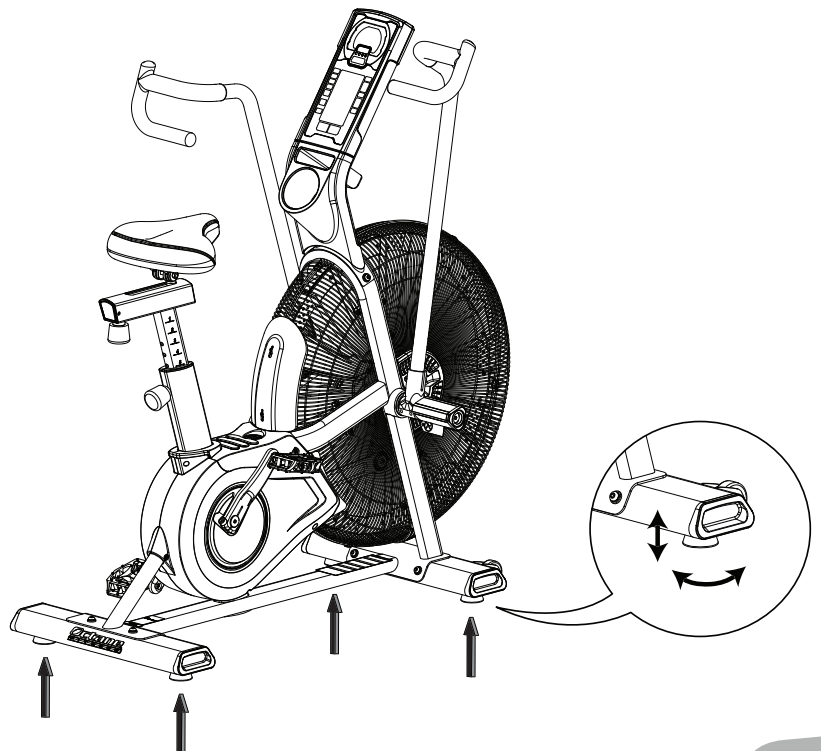

# FEATURES

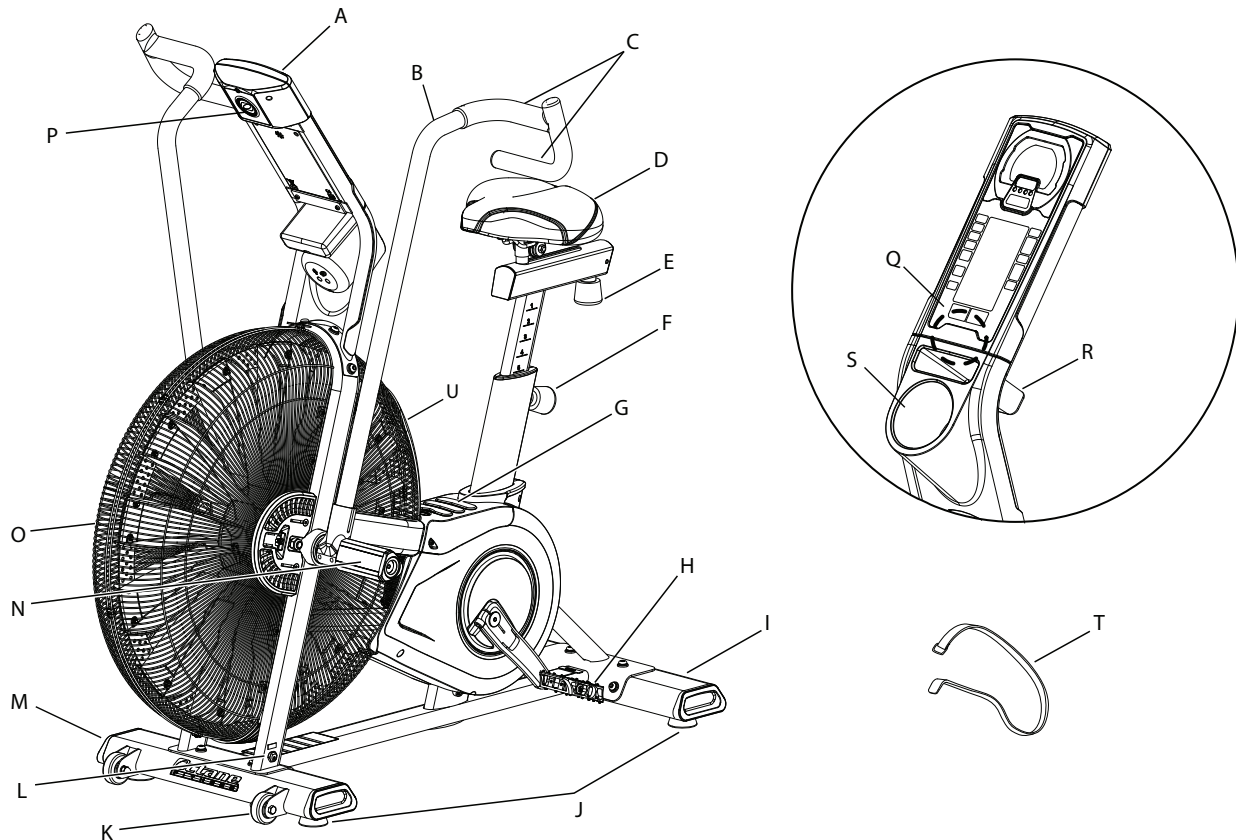

A	Console	H	Pedal	O	Air Resistance Fan
B	Handlebar	I	Stabilizer, Rear	P	Battery Compartment
C	Handle Grip	J	Leveler	Q	Telemetry Heart Rate (HR) Receiver
D	Seat	K	Transport Roller	R	Media Rack
E	Seat Slider Adjustment Knob	L	Power Connector	S	Water Bottle Holder
F	Seat Post Adjustment Knob	M	Stabilizer, Front	T	Transport and Immobilization Strap
G	Foot Step Pad	N	Foot Peg	U	Air Diverter

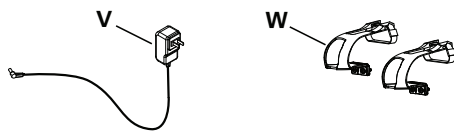

## Accessories

V	Power Adapter	W	Toe Restraint
---	---------------	---	---------------

To order:

In the United States— go to [www.octanefitness.com](http://www.octanefitness.com) or call 1 (888) OCTANE4 (628-2634).

Outside the United States— contact your local distributor.

**WARNING!** Use the values calculated or measured by the machine's computer for reference purposes only. The heart rate displayed is an approximation and should be used for reference only. Over exercising may result in serious injury or death. If you feel faint stop exercising immediately.



## Console Features

The Console provides information about your workout on the display screens.

### Programs

- Manual
- 20/10 Interval
- 30/90 Interval
- Custom Interval
- Time Target
- Heart Rate Zones
- Calorie Target
- Kilojoules Target
- Miles Target
- Kilometers Target

**Note:** Push and hold the RATE SELECT button for 3 seconds to go to SCAN mode and cycle through the rates automatically (CAL/MIN, WATTS, RPM, SPEED). Each rate is displayed for 3 seconds. To exit SCAN mode, push the Rate Select button.

Push the CAL MI kJ KM SELECT button and the ENTER button together and hold for 5 seconds to automatically show your last displayed metric (CAL/MI/kJ/KM) in the cumulative metrics field. The selection will be saved if the current workout runs for a minimum of 1 minute. The selected metric will be the default for all workouts except for the CAL/kJ Target workouts and MI/KM Target workouts. To exit the selection display mode, push the CAL MI kJ KM SELECT button and ENTER button together and hold for 5 seconds.

### Remote Heart Rate Monitor

Monitoring your Heart Rate is one of the best procedures to control the intensity of your exercise. The Console can read telemetry HR signals from a Heart Rate Chest Strap Transmitter that operates in the 4.5kHz - 5.5kHz range.

**Note:** The heart rate chest strap must be an uncoded heart rate strap from Polar Electro or an uncoded POLAR® compatible model. (Coded POLAR® heart rate straps such as POLAR® OwnCode® chest straps will not work with this equipment.)

**⚠ If you have a pacemaker or other implanted electronic device, consult your doctor before using a wireless chest strap or other telemetric heart rate monitor.**

### Auto-Calibration

The console has a built-in sensor which continually corrects for changes in altitude to maintain accurate measurement of fan resistance and watts used during exercise.

For additional information on your fitness machine, be sure to read the Owner's Manual provided online ( [www.octanefitness.com](http://www.octanefitness.com) ) or request a hard copy from customer service if you do not have online access.

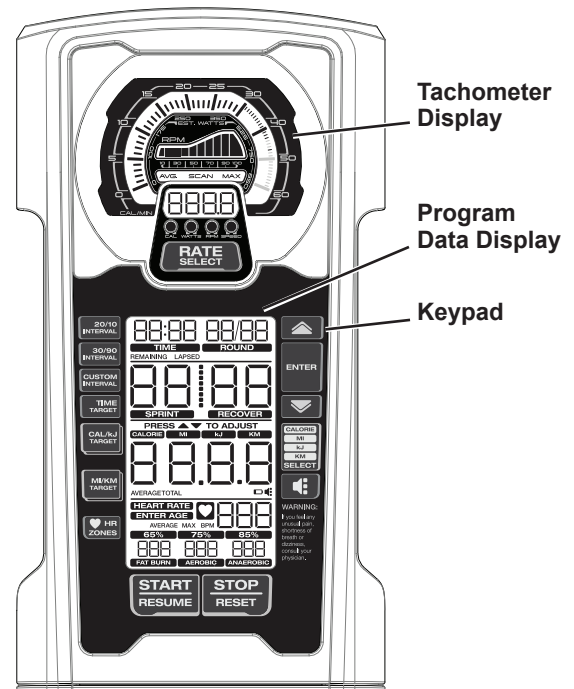

## What to Wear

Wear rubber-soled athletic shoes. You will need the appropriate clothes for exercise that allow you to move freely.

## How Often Should You Exercise

**⚠️ Consult a physician before you start an exercise program. Stop exercising if you feel pain or tightness in your chest, become short of breath, or feel faint. Contact your doctor before you use the machine again. Use the values calculated or measured by the machine's computer for reference purposes only. The heart rate displayed is an approximation and should be used for reference purposes only.**

- 3 times a week for 20 minutes each day.
- Schedule workouts in advance and try to follow the schedule.

## Seat Adjustment

Correct seat placement encourages exercise efficiency and comfort, while reducing the risk of injury.

1. With a Pedal in the forward position, place the heel of your foot to the lowest part of it. Your leg should be bent slightly at the knee.
2. If your leg is too straight or your foot cannot touch the Pedal, you need to move the seat downward. If your leg is bent too much, you need to move the seat upward.

**⚠️ Step off the machine before you adjust the seat.**

3. Loosen and pull the Seat Post Adjustment Knob on the Seat Post. Adjust the seat to the desired height.

**⚠️ Do not lift the Seat post above the "STOP" mark on the Seat Post.**

4. Release the Seat Post Adjustment Knob to engage the locking pin. Be sure that the pin is fully engaged and fully tighten the adjustment knob.
5. To move the seat closer to, or away from the console, loosen the seat adjustment knob. Slide the seat to the desired position and fully tighten the knob.

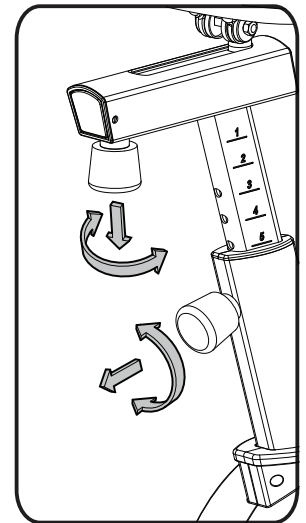

## Using the Machine

**⚠️ Be aware that the Pedals, Handlebars and Resistance Fan are connected and when any of these parts move, the others do as well.**

Carefully mount the machine using the Foot Step Pad if necessary. Adjust the Seat and Pedals before starting a workout.

Lower Body Workout: Slowly pedal with your arms relaxed at your sides or with your hands resting on the Hand Grips as the Handlebars move.

Full Body Workout: Grasp the Hand Grips with your palms down. Push and pull the Handlebars as you pedal, keeping your elbows low and next to your body.

Upper Body Workout: Grasp the Hand Grips firmly with palms down and place your feet on the Foot Pegs. Lean slightly forward at the hips with your back straight and shoulders down. Now push and pull the Handlebars

**Note:** You may need to safely push a Pedal to assist with starting the workout.

To increase the air resistance and workload, increase your level of activity. To exercise all the muscle groups in your arms, alter your grasp to palms up for part of the workout.

When done with your workout, reduce the Resistance Fan speed until the machine fully stops.

**⚠ This bike cannot stop the Pedals independently of the Resistance Fan. Reduce the pace to slow the Resistance Fan and Pedals to a stop. Do not dismount the bike until the Pedals have come to a complete stop. Be aware that the moving Pedals can strike the backs of the legs.**

### Locking the Fan Assembly / Storage

When the machine is not in use, be sure to lock the Fan Assembly with the Transport and Immobilization Strap. The fan assembly should be locked for storage of the machine.

**⚠ For safe storage of the machine, remove the batteries and install the Transport and Immobilization Strap to secure the Resistance Fan. Place the machine in a secure location away from children and pets. Be aware that the Pedals, Handlebars and Resistance Fan are connected and when any of these parts move, the others do as well.**

To lock the Fan Assembly:

1. Move the Pedals so that one Crank Arm is as close as possible to the Seat Post.
2. Wrap the Transport and Immobilization Strap (T) around the Crank Arm and the Seat Post and put the end of the strap through the metal ring. Tighten the strap to prevent movement of the Pedals and secure the strap.

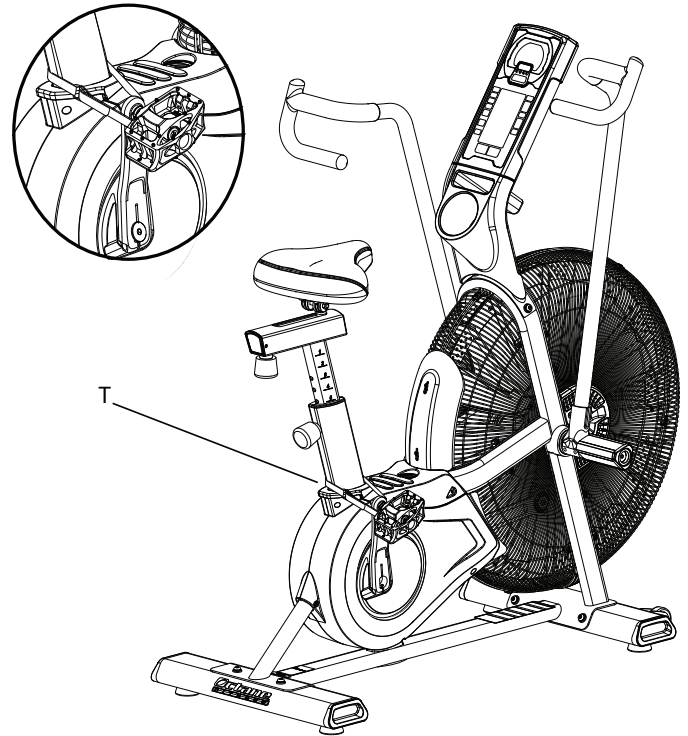

### Power-Up / Idle Mode

The Console will enter Power-Up / Idle Mode if any button is pushed, or if it receives a signal from the RPM sensor as a result of pedaling the machine.

**Note:** The Console will display the battery indicator if the battery level is 25% or less.

### Auto Shut-Off (Sleep Mode)

If the Console does not receive any input in approximately 2 minutes, it will automatically shut off. The LCD display is off while in Sleep Mode.

**Note:** The Console does not have an On/Off switch.

### Manual Workout

The Manual program lets you start a workout without entering any information.

1. Sit on the machine.
2. With the Console in Idle Mode, push the START/RESUME button to start the workout program, and start to pedal.
3. To pause the workout and see your metrics, push the STOP/RESET button one time. Push START/RESUME to continue.
4. When done with your workout, push the STOP/RESET button two times to end the workout.

## Heart Rate Zones

The Console allows you to set your Heart Rate Zones and use the calculated values to monitor your workout intensity. This feature can be used in conjunction with all of the other programs.

1. Sit on the machine.
2. With the Console in Idle Mode, push the HR ZONES button. The prompt "ENTER AGE" turns on. The default age is 35. To adjust the Age value, use the Increase/Decrease buttons and push ENTER.

The Console calculates values for the FAT BURN, AEROBIC and ANAEROBIC heart rate zone fields from the Age value.

 **Consult a physician before you start an exercise program. Stop exercising if you feel pain or tightness in your chest, become short of breath, or feel faint. Contact your doctor before you use the machine again. Use the values calculated or measured by the machine's computer for reference purposes only. The heart rate displayed on the console is an approximation and should be used for reference only.**

3. The HEART RATE display shows the heart rate in beats per minute (BPM) from a heart rate chest strap transmitter. The icon will flash when it has a signal from a HR chest strap.

**Note:** If no heart rate is detected, the display will be blank.

If the Console goes into Sleep Mode or the power is removed, the Age value is reset to default and the HR Zones turn off.

## Pausing / Results Mode

To pause a workout and see the workout summary:

1. Push the STOP/RESET button one time.

**Note:** The Console will automatically pause if there is no RPM signal for 5 minutes.

2. To continue your workout, push START/RESUME.

To end the workout, push the STOP/RESET button two times. The Console will go into Idle Mode.

When you complete or stop a workout, the Console will display a summary of your workout values. To stop a workout and see the summary, push STOP/RESET and the Console will go into Results mode.

The Tachometer Display shows the user's average CAL/MIN and WATTS, and the MAX CAL/MIN tick mark for that workout. The Tach hill shows the average RPM. The Tach metric display shows the average and maximum values for the selected metric. If the console was in SCAN mode, the display cycles through the average and maximum values for CAL/MIN, WATTS, RPM and SPEED.

The Program Data Display shows the total time, CALORIE, MI (miles), kJ (kilojoules), and KM (kilometers) metrics. Push the CAL MI KJ KM Select button to cycle through the metrics. The summary for Interval programs shows total time, rounds and interval time.

### Manual and Target Programs

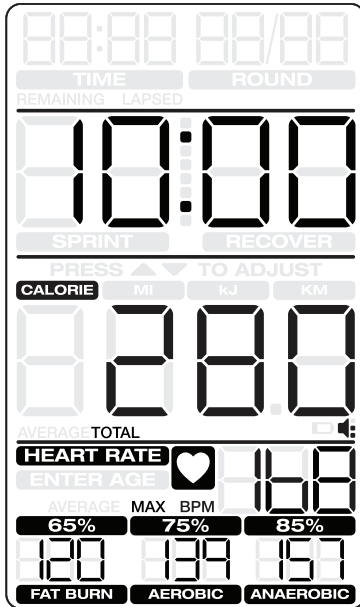

### Interval Programs

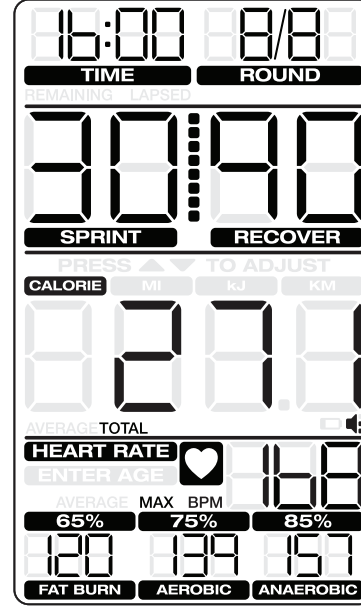

The Heart Rate area cycles the Average HR and MAX HR values. If HR Zones were calculated for the program, the values are displayed.

The Results display will show for 5 minutes and then reset.

Push STOP/RESET to stop the Results display and go back to Idle Mode.

For additional information on the operation of the Console, be sure to read the Owner's Manual provided online ( [www.octanefitness.com](http://www.octanefitness.com) ).

## MAINTENANCE

Read all maintenance instructions fully before you start any repair work. In some conditions, an assistant is required to do the necessary tasks.

**!** Equipment must be regularly examined for damage and repairs. The owner is responsible to make sure that regular maintenance is done. Worn or damaged components must be repaired or replaced immediately. Only manufacturer supplied components can be used to maintain and repair the equipment.

If at any time the Warning labels become loose, unreadable or dislodged, contact your local distributor or Octane Fitness Customer Service for replacement labels.

Disconnect all power to the machine before you service it.

**Daily:** Before each use, examine the exercise machine for loose, broken, damaged, or worn parts. Do not use if found in this condition. Repair or replace all parts at the first sign of wear or damage. After each workout, use a damp cloth to wipe your machine and Console free of moisture.

**Note:** Avoid excessive moisture on the Console.

**Weekly:** Clean the machine to remove any dust, dirt, or grime from the surfaces. Check for smooth seat operation. If needed, sparingly apply a thin coating of silicone lube to ease operation.

**!** Silicone lubricant is not intended for human consumption. Keep out of reach of children. Store in a safe place.

**Note:** Do not use petroleum based products.

**Monthly or after 20 hours:** Check pedals, crank arms and handlebars. Make sure all bolts and screws are tight. Tighten as necessary. Check drive belt for signs of wear. Rotate crank arms by hand and observe the belt through the fan cage.

**!** Be aware that the Crank Arms, Handlebars and Resistance Fan are connected and when any of these parts move, the others do as well.

**NOTICE:** Do not clean with a petroleum based solvent or an automotive cleaner. Be sure to keep the Console free of moisture.

**!** When the machine is used in a Studio/Institutional environment, we recommend that the Pedals be replaced every year to maintain maximum user safety and performance. Only use replacement pedals available from Octane. Other brands of Pedals may not be designed for Indoor Cycling or this product, and can cause danger to users and bystanders, and will void the warranty.

For additional information on maintaining your fitness machine, be sure to read the Owner's Manual provided online ( [www.octanefitness.com](http://www.octanefitness.com) ) or request a hard copy from customer service if you do not have online access.

**Who Is Covered**

This warranty is valid only to the original purchaser in the United States or Canada and is not transferable or applicable to any other person(s).

**What Is Covered**

Octane Fitness, LLC warrants that this product is free from defects in materials and workmanship, when used for the purpose intended, under normal conditions, and provided it receives proper care and maintenance as described in the Product's Assembly and Owner's manual. This warranty is good only for authentic, original, legitimate machines manufactured by Octane Fitness, LLC and sold through an authorized agent and used in the United States or Canada.

**Terms**

- Frame 10 years
- Mechanical parts 3 years
- Electronics 3 years
- Labor 6 months

(Labor support does not include the installation of replacement parts involved in the initial product assembly and preventative maintenance services.)

**How Octane Will Support the Warranty**

Throughout the terms of the warranty coverage, Octane Fitness, LLC will repair any machine that proves to be defective in materials or workmanship. Octane reserves the right to replace the product in the event a repair is not possible. When Octane determines replacement is the correct remedy, Octane may apply a limited credit reimbursement toward another Octane Fitness, LLC brand Product, at our discretion. This reimbursement may be prorated based on length of ownership. Octane Fitness, LLC provides repair service within major metropolitan areas. Octane Fitness, LLC reserves the right to charge the consumer for travel outside these areas. Octane Fitness, LLC is not responsible for dealer labor or maintenance charges beyond the applicable warranty period(s) stated herein. Octane Fitness, LLC reserves the right to substitute material, parts or products of equal or better quality if identical materials or products are not available at the time of service under this warranty. Any replacement of the product under the terms of the Warranty in no way extends the original Warranty period. Any limited credit reimbursement may be prorated based on length of ownership. THESE REMEDIES ARE THE EXCLUSIVE AND SOLE REMEDIES FOR ANY BREACH OF WARRANTY.

**What You Must Do**

- Retain appropriate and acceptable Proof of Purchase.
- Operate, maintain, and inspect the Product as specified in the Product Documentation (Assembly, Owner's Manuals, etc.).
- Product must be used exclusively for the purpose intended.
- Notify Octane within 30 days after detecting an issue with the Product.
- Install replacement parts or components in accordance with any Octane instructions.
- Perform diagnostic procedures with a trained Octane Fitness, LLC representative if requested.

**What Is Not Covered**

- Damage due to abuse, tampering or modification of the Product, failure to properly follow assembly instructions, maintenance instructions, or safety warnings as stated in the Product Documentation (Assembly, Owner's Manuals, etc), damage due to improper storage or the effect of environmental conditions such as moisture or weather, misuse, mishandling, accident, natural disasters, power surges.
- Damage caused by exceeding maximum user weights as defined in the Product's Owner's manual or warning label.
- Damage due to normal usage and wear and tear.
- This warranty does not extend to any territories or countries outside the United States and Canada.

**How to Obtain Service**

For Products purchased directly from Octane Fitness, LLC contact the Octane office listed on the Contacts page of the products Owner's manual. You may be required to return the defective component to a specified address for repair or inspection, at your expense. Standard ground shipping of any warranty replacement parts will be paid by Octane Fitness, LLC. For products purchased from a retailer, you may be asked to contact your retailer for warranty support.

**Exclusions**

The preceding warranties are the sole and exclusive express warranties made by TRUE Fitness. They supersede any prior, contrary or additional representations, whether oral or written. No agent, representative, dealer, person or employee has the authority to alter or increase the obligations or limitations of this warranty. Any implied warranties, including the WARRANTY OF MERCHANTABILITY and any WARRANTY OF FITNESS FOR A PARTICULAR PURPOSE, are limited in duration to the term of the applicable express warranty provided above, whichever is longer. Some states do not allow limitations on how long an implied warranty lasts, so the above limitation may not apply to you.

**Limitation of Remedies**

EXCEPT AS OTHERWISE REQUIRED BY APPLICABLE LAW, THE PURCHASER'S EXCLUSIVE REMEDY IS LIMITED TO REPAIR OR REPLACEMENT OF ANY COMPONENT DEEMED BY OCTANE FITNESS, LLC TO BE DEFECTIVE UNDER THE TERMS AND CONDITIONS STATED HEREIN. IN NO EVENT WILL OCTANE FITNESS, LLC BE LIABLE FOR ANY SPECIAL, CONSEQUENTIAL, INCIDENTAL, INDIRECT OR ECONOMIC DAMAGES, REGARDLESS OF THE THEORY OF LIABILITY (INCLUDING, WITHOUT LIMITATION, PRODUCT LIABILITY, NEGLIGENCE OR OTHER TORT) OR FOR ANY LOST REVENUE, PROFIT, DATA, PRIVACY OR FOR ANY PUNITIVE DAMAGES ARISING OUT OF OR RELATED TO THE USE OF THE FITNESS MACHINE EVEN IF OCTANE FITNESS, LLC HAS BEEN ADVISED OF THE POSSIBILITY OF SUCH DAMAGES. THIS EXCLUSION AND LIMITATION SHALL APPLY EVEN IF ANY REMEDY FAILS OF ITS ESSENTIAL PURPOSE. SOME STATES DO NOT ALLOW THE EXCLUSION OR LIMITATION OF CONSEQUENTIAL OR INCIDENTAL TYPE DAMAGES SO THE ABOVE LIMITATION MAY NOT APPLY TO YOU.

**State Laws**

This warranty gives you specific legal rights. You may also have other rights, which vary from state to state.

**Expirations**

If the warranty has expired, Octane Fitness, LLC. may assist with replacements or repairs to parts and labor, but there will be a charge for these services. Contact an Octane office for information on post-warranty parts and services. Octane does not guarantee availability of spare parts after expiration of warranty period.

**International Purchases**

If you purchased your machine outside of the United States consult your local distributor or dealer for warranty coverage.

