

FITNESS LINE FUNCTIONAL TRAINER

 TRUE FITNESS



MODEL FS-100-35
MAN-FS-100-35 REV01

**OWNER'S
MANUAL**



IMPORTANT—PLEASE READ

IMPORTANT!

All products shown are prototype. Actual product delivered may vary. Product specifications, features, and software are subject to change without notice.

For the most up-to-date version of this manual, please see our website:
<https://truefitness.com/support/user-manuals/>

IMPORTANTE!

Todos los productos mostrados son prototipos. La realidad el producto suministrado puede diferir. Especificaciones de productos, características y software están sujetas a cambios sin previo aviso.

Para la más actualizada de este manual del propietario y para los documentos en otros idiomas, por favor visite <https://truefitness.com/support/user-manuals/>

IMPORTANT! Tous les produits présentés sont prototype. Le produit réel livré peut varier. Spécifications du produit, caractéristiques et logiciels sont sujettes à modification sans préavis. Pour la plus à jour le manuel du propriétaire et pour documents dans des langues supplémentaires, veuillez <https://truefitness.com/support/user-manuals/> de visite

重要提示!

显示所有产品的原型。实际交付的产品可能有所不同产品规格,功能和软件如有更改,恕不另行通知迄今为止对于大多数的使用说明书,和对于其他语言的文档,请访问<https://truefitness.com/support/user-manuals/>

اہم!

اہم یں سٹیل عفلہ جتنمہا فلتخت دق . جڈومنہا یہ ضرور عملہ تاجتہما عمیج

راعش! نود ری ی غتلل قلاباق جم اربل او تازیما او ، جتنمہا تافصاوم

مظعمہا <https://truefitness.com/support/user-manuals/> قرازی ی جری کلامہا لیلد نآلا یتح لصی ام مظعمہا

<https://truefitness.com/support/user-manuals/> قرازی ی جری ، عیفاض! تاغل یف تادنتسمہل

WICHTIG!

Alle hier gezeigten Produkte sind Prototypen. Das tatsächliche Produkt ausgeliefert wird, kann variieren. Produkt-Spezifikationen, Funktionen und Software können sich ohne vorherige Ankündigung ändern. In den meisten Fällen bis zu Bedienungsanleitung Bisher besuchen und für Dokumente in weiteren Sprachen finden Sie unter <https://truefitness.com/support/user-manuals/>

BELANGRIJK!

Alle getoonde producten zijn prototype. Daadwerkelijke product geleverd kan verschillen. Product specificaties, eigenschappen & software zijn onderhevig aan verandering zonder kennisgeving. Voor de meest actuele handleiding van de eigenaar & voor documenten in andere talen kunt u terecht op <https://truefitness.com/support/user-manuals/>

ВАЖНО!

Все товары указаны прототипа. Фактический продукт, поставляемый могут отличаться. Технические характеристики, особенности и программного обеспечения могут быть изменены без предварительного уведомления. Для получения самой последней на сегодняшний день руководство по эксплуатации и Для документов на другие языки, пожалуйста, посетите <https://truefitness.com/support/user-manuals/>

THANK YOU FOR CHOOSING TRUE

Since its founding in 1981, TRUE Fitness has been built on two core guiding principles: Build the highest quality products and support them with superior service. Today, TRUE is the global leader in premium fitness equipment for the commercial and residential markets.

Over the years, the fitness industry has changed, new markets have sprung up, and the needs of our customers have evolved, but those principles remain constant, and we remain ever-vigilant in working to achieve them.

In keeping with our values, TRUE has always striven to equip our machines with the latest technology and safety features since the beginning, giving our customers the very best exercise experience possible while providing peace of mind.

As your dedicated partner, we will do whatever it takes to keep your facility going strong. Our experienced team provides end-to-end service, from facility planning and maintenance to providing your machines with the newest technologies. You can count on TRUE Fitness for the best service in the industry, provided by a team focused on optimizing the life of your equipment.

CONTACTING OUR SUPPORT TEAM

Before you contact TRUE, we recommend gathering the serial number, model number, and a brief description of the reason for your request. After you have all the pertinent information, we suggest you contact your selling dealer or local service company to set up an appointment. If you are not familiar with who is in your area, you can visit <https://shop.truefitness.com/store-locator/> and use our store locator to obtain the contact information for the closest dealer.

If you still need help, please contact our product support team.

Address	TRUE Fitness Attn: Product Support 865 Hoff Road St. Louis, MO 63366
Phone	800.883.8783
Email	service@truefitness.com
Hours of Operation	Monday - Friday 8:30am - 5:00pm (CST)

CONTACTING OUR SALES TEAM

Interested in owning more TRUE products? Please contact us with any product inquires so that we may direct you to the appropriate sales representative to help answer your questions.

Address	TRUE Fitness Attn: Sales Department 865 Hoff Road St. Louis, MO 63366
Phone	800.426.6570
Email	sales@truefitness.com
Hours of Operation	Monday - Friday 8:30am - 5:00pm (CST)



REPORTING FREIGHT CLAIMS OR PARTS DAMAGE

Unfortunately, sometimes materials can be damaged during shipment. If materials are damaged during shipment, please follow the guidelines below to determine the appropriate process for you to follow.

Severe Damage—Obvious damage to external packaging and internal product.

Please refuse the shipment and it will be returned to TRUE by the carrier. Contact TRUE product support by calling 800.883.8783 or sales support by calling 800.426.6570 Monday-Friday during normal business hours to notify us that the shipment has been refused. Once we have received the damaged shipment, a replacement shipment will be sent to you. If the shipment comes in multiple boxes, only refuse boxes with damage.

Slight Damage—Minimal damage to external packaging with unknown internal damage to product.

If the shipment has minimal damages and you are not sure if the actual product is damaged, you must sign the bill of lading as damaged when accepting the shipment. Once you have opened the box and you have determined something is indeed damaged, please gather the serial number, model number, description of damage, and photos of damage. Please make sure the photos include the damaged product as well as the damaged box the product arrived in. Contact TRUE product support (service@truefitness.com // 800.883.8783) or TRUE sales support (sales@truefitness.com // 800.426.6570) Monday-Friday during normal business hours.

Concealed Damage—No damage to external packaging but internal damage to product.

You may receive a shipment that looks intact and discover once the box has been opened that there are hidden damages. Please notify the carrier immediately. TRUE will not be able to file a claim if the carrier is not notified in a timely manner. Once you have called the carrier you will need to gather the serial number, model number, description of damage, and photos of damage. Contact TRUE product support (service@truefitness.com // 800.883.8783) or TRUE sales support (sales@truefitness.com // 800.426.6570) Monday-Friday during normal business hours.

TABLE OF CONTENTS

SAFETY INSTRUCTIONS

IMPORTANT SAFETY INSTRUCTIONS—SAVE THESE INSTRUCTIONS.....	6
GENERAL CARE AND MAINTENANCE.....	8
COMMERCIAL MAINTENANCE SCHEDULE.....	9
COMPLIANCES.....	9
DIMENSIONS AND WEIGHTS.....	10
FEATURES.....	11
LABEL LOCATIONS.....	12
WARNING AND INTENDED USE LABELS.....	13
OPTIONAL ACCESSORIES.....	15

ASSEMBLY INSTRUCTIONS

PREASSEMBLY CHECKLIST.....	16
ASSEMBLY STEPS.....	20

PREVENTATIVE MAINTENANCE

DAILY INSPECTION AND MAINTENANCE.....	31
WEEKLY INSPECTION AND MAINTENANCE.....	31
OTHER SCHEDULED PREVENTATIVE MAINTENANCE.....	32
CLEANING THE EQUIPMENT.....	32
CABLE INSPECTION AND MAINTENANCE.....	33
WEIGHT STACK SELECTOR PIN INSPECTION.....	36

WARRANTY INFORMATION

COMMERCIAL LIMITED WARRANTY.....	37
----------------------------------	----



SAFETY INSTRUCTIONS

IMPORTANT SAFETY INSTRUCTIONS—SAVE THESE INSTRUCTIONS

FACILITY AND USER SAFETY PRECAUTIONS

- Review and understand all of the warning labels affixed to this machine and on the facility safety sign.
- Be certain that the machine operation is understood before it is used. Refer to the instructional procedure label affixed to the machine.
- Make sure all users are properly trained on how to use this equipment. If this machine is being used in a commercial setting, end users may not have access to this owners manual. It is the responsibility of the facility to instruct users as to the proper usage of the equipment as well as making them aware of potential hazards. Maximum user weight is 300 lbs / 136 kg.
- Use each machine only for the intended exercise. Do not allow anyone to invent exercises not included on the instructional procedure label or the intended use label.
- Do not modify the machine.
- This equipment meets industry safety standards for stability when used for the intended exercise. Do not allow straps, resistance bands or other means to be attached to the framework of this machine to perform stretching or body weight exercises. This can result in machine instability and lead to serious crushing injuries.
- Keep children away from this equipment. Adults should closely supervise use by teenagers.
- It is recommended that users receive a thorough medical exam before commencing an exercise program. All medical issues should be reviewed to ensure that weight training will not aggravate pre-existing medical conditions.
- If the machine appears damaged or inoperable, contact a facility staff member to place an “OUT OF ORDER, DO NOT USE” sign on the machine until it is repaired. Only use TRUE supplied replacement components to service this machine.
- Instruct users not to wear loose or dangling clothes or have headphone wires hanging when using this equipment.
- Do not attempt to free any jammed assemblies by yourself as this may cause injury.
- On Plate Loaded and Free Weight machines:
 - Use of spotter(s). Instruct users to seek the advice of the facility staff as to the appropriate use of spotters when lifting. More than one spotter may be required depending upon the amount of weight being lifted.
 - Instruct users to load weight plates evenly and carefully to avoid tipping equipment and crushing injuries.
 - If the machine is equipped with safety stops or catches, inspect them and verify their proper operation before use and make sure they are securely in place before using or exiting the machine. Be certain members are instructed on how to operate and adjust all safety mechanisms.
 - This equipment is designed for standard olympic size weight plates with a 50mm bore (1.9”).
 - Do not exceed the maximum weight capacity of the machine. Maximum plate size is 45 lbs (25 kg).
- On Selectorized and Cable equipped machines:
 - Do not allow users to perform any exercise by holding the end of the cable and/or the cable end fitting. Use only appropriate handles or attachments properly connected to the cable end.
 - Do not high-pin or double-pin the weight stack. Do not allow the machine to be used if the top plate or weight stack is pinned in a raised position. Use an assistant and carefully return the machine to the proper position with the cap plate resting on the top weight. Inspect the entire length of the cable to ensure that it is properly seated in all of the pulley grooves.
 - Do not allow the use of weight plates or dumbbells to be used as a means to add additional weight to the weight stacks. Use only the TRUE adder weight system specifically designed for the machine.

INSTALLATION SAFETY PRECAUTIONS

- Read this installation manual entirely before assembling this equipment.
- Verify that there is adequate space surrounding this piece of equipment for safe access and operation. Installation must meet ADA requirements for accessibility.
- Install this piece of equipment on a solid level surface that does not deviate more than 1/8" over a 10' distance (or as defined and required by local building and architectural codes.)
- **TRUE strongly recommends that all equipment be anchored to the floor to prevent movement and increase stability.**
 - Due to the wide variation of flooring on which the unit can be installed, contact a qualified contractor to determine an appropriate fastening system for your floor.
 - Use 3/8" diameter hardware (10 mm) to anchor the machine. Anchors should have a minimum pull out force of 220 lb (110 kg) for each position.
 - When attaching the machine to the floor, if there is a gap between the machine foot and the floor, do not use the anchor to remove the gap as this can cause the machine frame to deform. Instead, place a shim between the bottom of the foot and the floor, then tighten the anchor.
 - Anchoring holes are provided on the feet of the frame. All anchoring locations must be used when anchoring the equipment to the floor.
- **DO NOT** install any fitness equipment near a pool, hot tub or other damp locations. Corrosion caused by installation in these locations can lead to premature failure of components.
- Be sure all hardware is tight before using this machine.
- Some assembly materials may come preassembled in the carton. Refer to the Assembly Instructions for instructions on disassembling assembly materials where appropriate before beginning assembly.

MAINTENANCE SAFETY PRECAUTIONS

- Refer to the maintenance schedule table in this manual for when to perform maintenance.
- Check the function of your machine DAILY by verifying the following:
 - If equipped with cables, inspect cables and end fittings for any signs of wear. Replace if worn, frayed, or damaged with TRUE replacement components.
 - Verify that all adjustments are possible and carried out with ease. Make sure that each adjustment pin inserts completely into each position without binding.
 - Verify that safety catches and stops are in proper working order and engaged.
 - Verify that the exercise is performed smoothly, free of noise, and/or binding.
 - If equipped with a weight stack, verify that the proper weight selector pin is in place.
- Check the function of your machine WEEKLY by verifying the following:
 - Nuts, bolts, and fasteners—check tightness weekly. If any hardware has become loose, retighten and/or use Loctite™ brand Threadlocker 242. Be sure all hardware is tight before using the machine.
 - Frames and Lifting Arms: Inspect weekly for integrity and function. Replace any component at first signs of wear. Use only TRUE supplied components.
- Replace any warning label at the first sign of wear. Labels and the facility safety sign may be obtained from TRUE.



GENERAL CARE AND MAINTENANCE

IMPORTANT

Preventative maintenance is crucial to maintaining the function and safety of this equipment. Your facility must establish written guidelines for preventative maintenance and keep written or online records of the maintenance performed on these products. As a minimum, the items presented in the SAFETY section of this document and the items that follow here, should be included in your maintenance program.

- Cables (if equipped)—inspect end fittings daily for wear. Inspect the entire length of the cable weekly. Replace cables at the first sign of wear and on an annual basis. If the cable tension has been adjusted, be certain that the cable nut is tight.
- Nuts, bolts, and fasteners—check tightness weekly. If any hardware has become loose, retighten and/or use Loctite™ brand Threadlocker 242. Be sure all hardware is tight before using the machine.
- Safety catches—inspect catches, stop rods and their associated fasteners. Tighten any loose hardware and replace any components at first signs of wear.
- Frames—sweat, disinfecting sprays and spills can lead to corrosion which may lead to premature failure of components. Wipe all machines down with a damp cloth and dry completely each day. This includes painted parts, chrome parts and upholstered pads.
- Painted and chrome plated parts—use Simple Green with a dilution of 32:1 or similar cleaner for light dirt and grime. Use Turtle Wax Polishing Compound or a good car polish to remove heavier dirt and grease as well as for polishing. DO NOT use solvents, lacquer thinner, acetone or finger nail polish remover. For scuffs and marks that are not removed by the above methods use a soft scrub cleanser. Make sure all parts are dry upon completion.
- Weight stack enclosures (shrouds) (if equipped)—wipe down with a damp cloth as needed.
- Exercise instruction labels—clean with soap and water as needed.
- Guide rods (if equipped)—wipe all dirt and dust from the guide rods before applying a light application of a teflon (PTFE) spray lubricant. Spray the lubricant on a rag and then wipe the guide rods with the rag. **DO NOT** use oil lubricants such as WD-40.

 CAUTION: Teflon (PTFE) lubricant will stain carpet and clothing.

- Bronze bushings—check monthly for signs of wear and replace as needed.
- Linear bearing shafts—wipe any accumulation of dust or other contaminants from the shafts on a weekly basis. Apply a thin layer of a Teflon® (PTFE) grease on a weekly basis. TRUE recommends Magnalube® brand.
- When replacing any component, use only TRUE supplied parts.
- Be sure all hardware is tight before using the machine.

Retain these instructions for future reference. If you have any questions, do not hesitate to contact your TRUE dealer or TRUE product support (service@truefitness.com // 800.883.8783).

COMMERCIAL MAINTENANCE SCHEDULE

Commercial Maintenance Schedule					
	Daily	Weekly	Monthly	6 Months	Annually
Inspect cables for wear, tension, and proper connection if equipped. Replace at the first sign of wear.	X				
Inspect cable length and cable end fittings. Replace at the first sign of wear.		X			
Inspect all nuts and bolts and tighten if needed.		X			
Inspect safety catches, stop rods, and their fasteners. Replace at the first sign of wear.	X				
Inspect all anti-slip surfaces and replace as needed.		X			
Inspect all adjustment pins, weight stack pins, set screws, gas shocks, snap links, and pulleys if equipped.	X				
Inspect all accessory bars and handles.		X			
Inspect all safety and instructional decals.	X				
Inspect all weight stack shields if equipped.	X				
Clean guide rods and lubricate with a teflon lubricant if equipped.			X		
Clean upholstery.	X				
Lubricate pivot bearings and linear bearings.				X	
Replace cables if equipped.					X

COMPLIANCES

This equipment complies with all applicable codes and regulations. For a complete list of compliances, please visit www.truefitness.com.



DIMENSIONS AND WEIGHTS

- **DIMENSIONS (L X W X H)**
39" x 63" x 88" / 99 cm x 159 cm x 222 cm
- **MACHINE WEIGHT**
505 lbs / 229 kg
- **MAXIMUM USER WEIGHT**
300 lbs / 136 kg

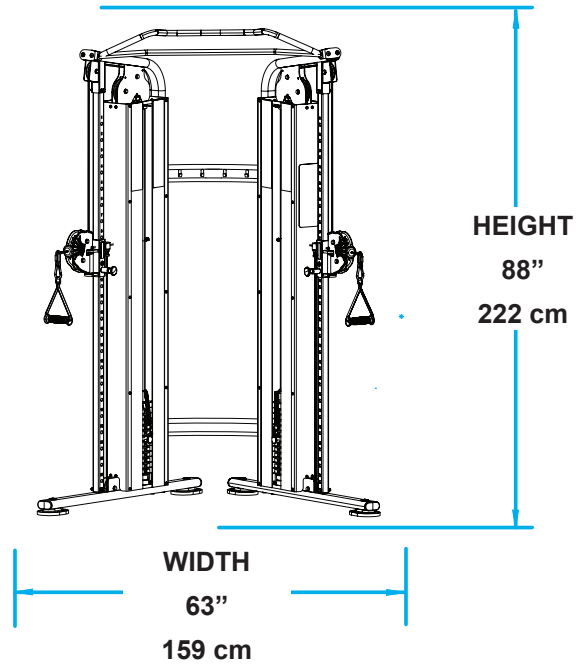
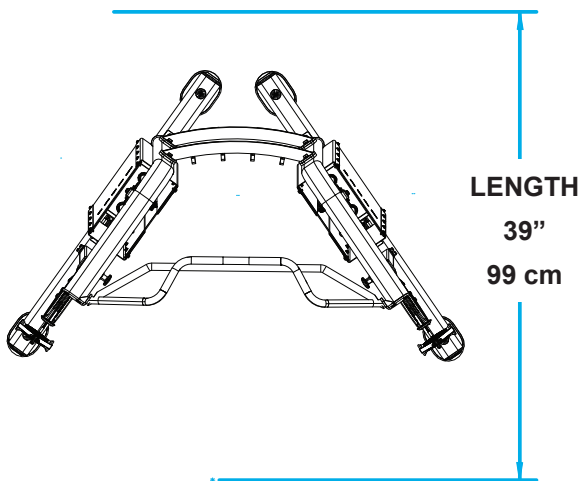



FEATURES

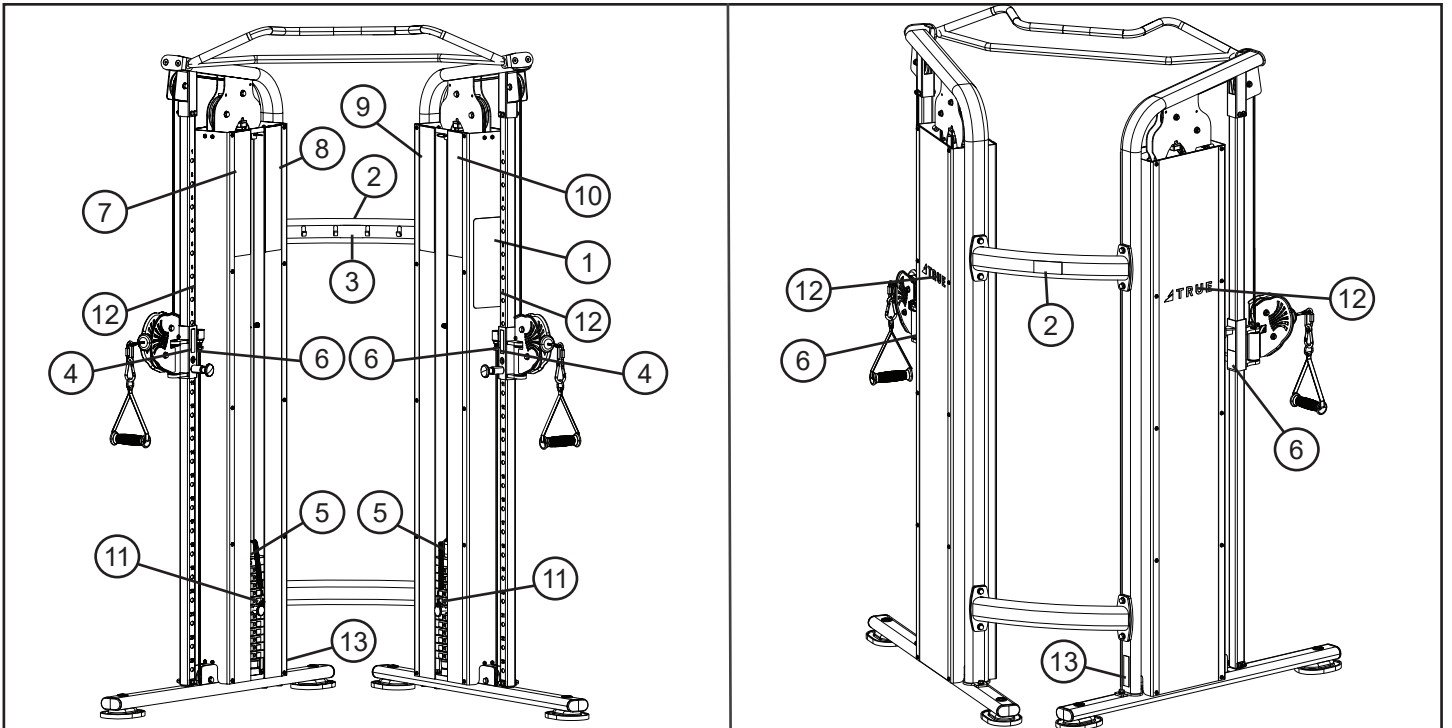

- Two 130lb. [59 kg.] fully independent weight stacks.
- The cable/pulley arrangement on this machine provides a 2:1 weight reduction. This means that the handle pull force required to raise the entire 130 lb. weight stack is actually 65 lb. The advantage of this for functional training is that the weight stack has 1/2 the momentum and 2 times the cable travel of a conventional 1:1 ratio machine.
- (13) weight stack settings, 5 lbs - 65 lbs. Pull force increments are 5.0lbs [2.3 kg].
- 65 lb. [29.5 kg.] max resistance at cable end (per handle).
- Cable travel is 8 feet (96 inches) [244 cm.] per handle.
- Machine weight = 505 lbs. [229 kg.]
- Floor loading = 48 lbs/ft² [233 kg/m²]
- 23 vertical arm adjustments labeled “1” through “23”.
- MAXIMUM user weight for pull up bar = 300 lbs. (136 kg.)
- The machine is shipped in two cartons of equal size: 84” x 27” x 6.5” (213 cm x 68 cm x 16.5 cm)
- Carton 1 weight = 143 lbs (65 kg.) and Carton 2 weight = 152 lbs. (69.1 kg.)

LABEL LOCATIONS

Item	Part	Description	Qty
1	LBL-WRN-XFT300	WARNING LABEL, XFT300	1
2	LBL-WRN-0006	LABEL, DO NOT EXERCISE FROM REAR OR SIDES	1
3	LBL-WRN-0012	LABEL, DO NOT ATTACH STRAPS	1
4	B2065	LABEL, WARNING, COMPLETELY INSERT PIN	2
5	B2141C	LABEL, WARNING, 1" CABLE BLT HT.	2
6	B2051	LABEL, WARNING, CABLE END INSPECTION	2
7	LBL-PR-FS100LLBK	LABEL, PROCEDURE, LEFT SIDE FRAME, LEFT PANEL BLACK	1
8	LBL-PR-FS100LRBK	LABEL, PROCEDURE, LEFT SIDE FRAME, RIGHT PANEL BLACK	1
9	LBL-PR-FS100RLBK	LABEL, PROCEDURE, RIGHT SIDE FRAME, LEFT PANEL BLACK	1
10	LBL-PR-FS100RRBK	LABEL, PROCEDURE, RIGHT SIDE FRAME, RIGHT PANEL CHARCOAL	1
11	LBL-WSEM-01065	WEIGHT STACK LABEL FS100	2
12	LBL-LOG-008BK	8IN BLACK TRUE LOGO	1
13	FS-00-LBLSN	LABEL, SERIAL NUMBER	2



Part	Image																								
LBL-PR-FS100LRBK	 <p>FS-100 Functional Trainer</p> <p>SHOULDER PRESS</p> <p>SHOULDERS</p> <p>LATERAL RAISE</p> <p>UPRIGHT ROW</p> <p>ARMS</p> <p>BICEP CURL</p> <p>TRICEP PUSHDOWN</p>																								
LBL-PR-FS100RLBK	 <p>TRUE</p> <p>FRONTHAND SWING</p> <p>SPORTS SPECIFIC</p> <p>BACKHAND SWING</p> <p>UNDERHAND SWING</p> <p>OVERHAND SWING</p>																								
LBL-PR-FS100RRBK	 <p>FS-100 Functional Trainer</p> <p>SQUAT PRESS</p> <p>LEGS</p> <p>OUTER THIGH</p> <p>INNER THIGH</p> <p>KICK BACK</p>																								
LBL-WSEM-01065	<table border="0"> <tr><td>4.5</td><td>10</td></tr> <tr><td>6.0</td><td>15</td></tr> <tr><td>9.0</td><td>20</td></tr> <tr><td>11.3</td><td>25</td></tr> <tr><td>13.6</td><td>30</td></tr> <tr><td>15.9</td><td>35</td></tr> <tr><td>18.2</td><td>40</td></tr> <tr><td>20.4</td><td>45</td></tr> <tr><td>22.7</td><td>50</td></tr> <tr><td>24.9</td><td>55</td></tr> <tr><td>27.2</td><td>60</td></tr> <tr><td>29.5</td><td>65</td></tr> </table>	4.5	10	6.0	15	9.0	20	11.3	25	13.6	30	15.9	35	18.2	40	20.4	45	22.7	50	24.9	55	27.2	60	29.5	65
4.5	10																								
6.0	15																								
9.0	20																								
11.3	25																								
13.6	30																								
15.9	35																								
18.2	40																								
20.4	45																								
22.7	50																								
24.9	55																								
27.2	60																								
29.5	65																								

Part	Image
LBL-LOG-008BK	
FS-00-LBLSN	

OPTIONAL ACCESSORIES

An optional accessory kit is available for your FS100 (XFT-100-ACC-KIT). An assortment of handles and cable attachments are included to allow users to perform more diverse exercises and target specific muscles and movements more completely.





ASSEMBLY INSTRUCTIONS

PREASSEMBLY CHECKLIST

BASIC GUIDELINES FOR SETTING UP THE EQUIPMENT

After removing the equipment from the packaging, place the equipment on a clean, level surface.

⚠ CAUTION:



Use caution when assembling the equipment.

Unpacking and assembling of this product is a two person task.















Use caution when unpacking this product. Avoid damage to the product.

DO NOT use a box cutter. **DO NOT** slice into the packaging.

VERIFY BOX CONTENTS

IMPORTANT! Please verify box contents. If you have questions, or if there are any missing parts, contact product support (service@truefitness.com // 800.883.8783).

TOOLS NEEDED FOR ASSEMBLY		INCLUDED IN BOX
7/16" Socket Wrench		NO
9/16" Socket Wrench		NO
7/32" Allen Wrench		NO
3/8" Wrench		NO
7/16" Wrench		NO
9/16" Wrench		NO





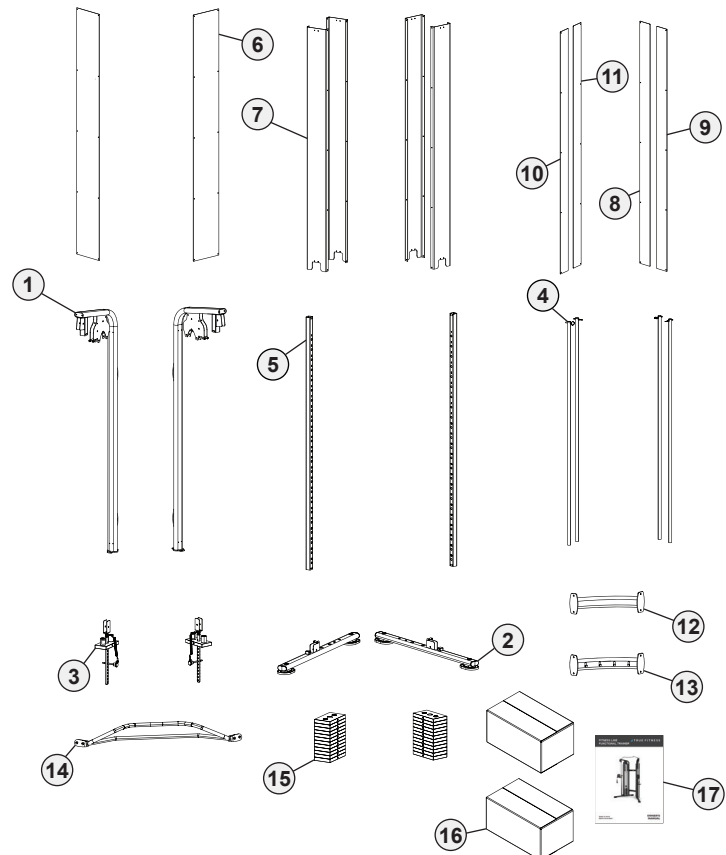

TOOLS NEEDED FOR ASSEMBLY		INCLUDED IN BOX
#2 Phillips Screwdriver		NO
Wire Cutters		NO
Cloth		NO
Lubricant		NO
Isopropyl Alcohol		NO
Step Ladder (Highly Recommended)		NO



BOX CONTENTS

ITEM	PART NUMBER	DESCRIPTION	QTY
1	FS100-MFR000-35	WELDMENT, SIDE FRAME	2
2	FS100-BFR000X-35	SUBASSEMBLY, BASE FRAME ASSEMBLY	2
3	FS100-TPL000X-35	TOP PLATE & PULLEY HOUSING ASSEMBLY	2
4	FS100-GDR001	GUIDE ROD	4
5	FS100-CLM001	CHROME ADJUSTMENT COLUMN	2
6	FS100-RSH000XBK	SHROUD PANEL ASSEMBLY, REAR BLACK	2
7	FS100-SHD001-35	SHROUD, SIDE PANEL, METAL	4
8	FS100-FSRL0XBK	FRONT SHROUD ASSEMBLY, RIGHT SIDE FRAME, LEFT PANEL W/O LOGO BLACK	1
9	FS100-FSRR0XBK	FRONT SHROUD ASSEMBLY, RIGHT SIDE FRAME, RIGHT PANEL W/O LOGO BLACK	1
10	FS100-FSLL0XBK	FRONT SHROUD ASSEMBLY, LEFT SIDE FRAME, LEFT PANEL W/O LOGO BLACK	1
11	FS100-FSLR0XBK	FRONT SHROUD ASSEMBLY, LEFT SIDE FRAME, RIGHT PANEL W/O LOGO BLACK	1
12	FS100-CBR000-35	WELDMENT, CROSS BRACE, LOWER	1
13	FS100-CBR100X-35	SUBASSEMBLY, CROSS BRACE, UPPER	1
14	FS100-CBR200	FS100 CHIN-UP BAR	1
15	S 502	WEIGHT PLATE 10LB	24
16	FS100-HWR	HARDWARE BOX	2
17	MAN-FS100	MANUAL, FS100	1

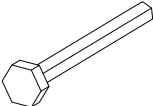

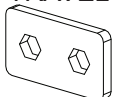

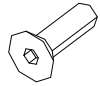
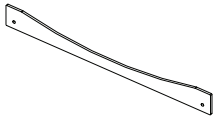

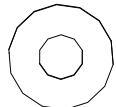
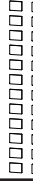
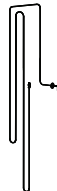
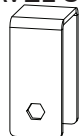

HARDWARE PACK CONTENTS

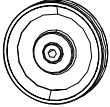
FS100 HARDWARE PACK		
ITEM	DESCRIPTION	QTY
C 907	SCREW, 10-32 X 1/2", PAN HD. PHILLIPS, ZP 	56
C 900A	WASHER, FLAT, #10 USS 	80
C 445	HH SCREW, 3/8"-16, 1" 	12
C 749	WASHER, LOCK, 3/8", ZP 	12
C 754C	WASHER, FLAT, 3/8" SAE, ZP 	40
C 416	HH SCREW, 1/4"-20, 2-1/4" 	8
C 752	WASHER, FLAT, 1/4" SAE 	16
C 740	LOCK NUT, 1/4"-20 NYL INS 	8
FS100- STP001	STOP, COLUMN TRAVEL 	4

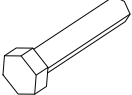

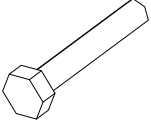
FS100 HARDWARE PACK		
ITEM	DESCRIPTION	QTY
C 659ZP	FH SCREW, 3/8"- 16, 1-1/4", ZP, LOCK PATCH 	4
FS100- SHD003-35	SHROUD BACKING PLATE 	8
C 900D	LOCK NUT, 10-32, NYL INS JAM NUT 	24
RX-R-C-4005	BUMPER, 26MM ID X 25MM THICK 	8
C 757	WASHER, FLAT, 1" USS 	8
LBL- WSEM-01065	WEIGHT STACK LABEL FS100 	2
FS100- CBL000X	CABLE ASSEMBLY 	2
FS100- PH011-35	U-SHAPED PULLEY TRAVEL STOP 	2

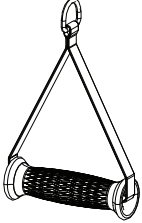
HARDWARE PACK CONTENTS

FS100 HARDWARE PACK		
ITEM	DESCRIPTION	QTY
B 900A	4-1/2 PULLEY W/ 3/16 GROOVE 	2
B 901	3-1/2 PULLEY W/ 3/16 GROOVE, 1" LG 	12
C 448	HH SCREW, 3/8"-16, 1-3/4" 	12
C 766A	LOCK NUT, 3/8"-16, NYL INS JAM NUT 	14
C 453	HH SCREW, 3/8"-16, 2" 	2
B1005	#2450-8 5/16" SNAP HOOK, ZINC 	2
B1110ABK	FS100 HANDLE BLACK 	2

ASSEMBLY STEPS

Step 1—Attach Frame Assembly

Tools Used in this Step	
#2 Phillips Screwdriver	
9/16" Socket Wrench	

Parts Used in this Step			
Item	Part	Description	Qty
1	FS100-BFR000X-35	SUBASSEMBLY, BASE FRAME ASSEMBLY	2
2	FS100-MFR000-35	WELDMENT, SIDE FRAME	2
3	FS100-SHD001-35	SHROUD, SIDE PANEL, METAL	4
4	C 907	SCREW, 10-32 X 1/2", PAN HD. PHILLIPS, ZP	16
5	C 900A	WASHER, FLAT, #10 USS	16
6	C 445	HH SCREW, 3/8"-16, 1"	4
7	C 749	WASHER, LOCK, 3/8", ZP	4
8	C 754C	WASHER, FLAT, 3/8" SAE, ZP	4

- Using a #2 Phillips screwdriver and a 9/16" socket wrench, attach the side panel shrouds to the left and right base frames using 4 bolts, 4 lock washers, 4 flat washers, 8 screws, and 8 smaller flat washers, but do not tighten.
- Using a #2 Phillips screwdriver, attach the left and right side frames to the side panel shrouds using 8 screws and 8 flat washers, but do not tighten.

IMPORTANT! DO NOT fully tighten the hardware until step 2.

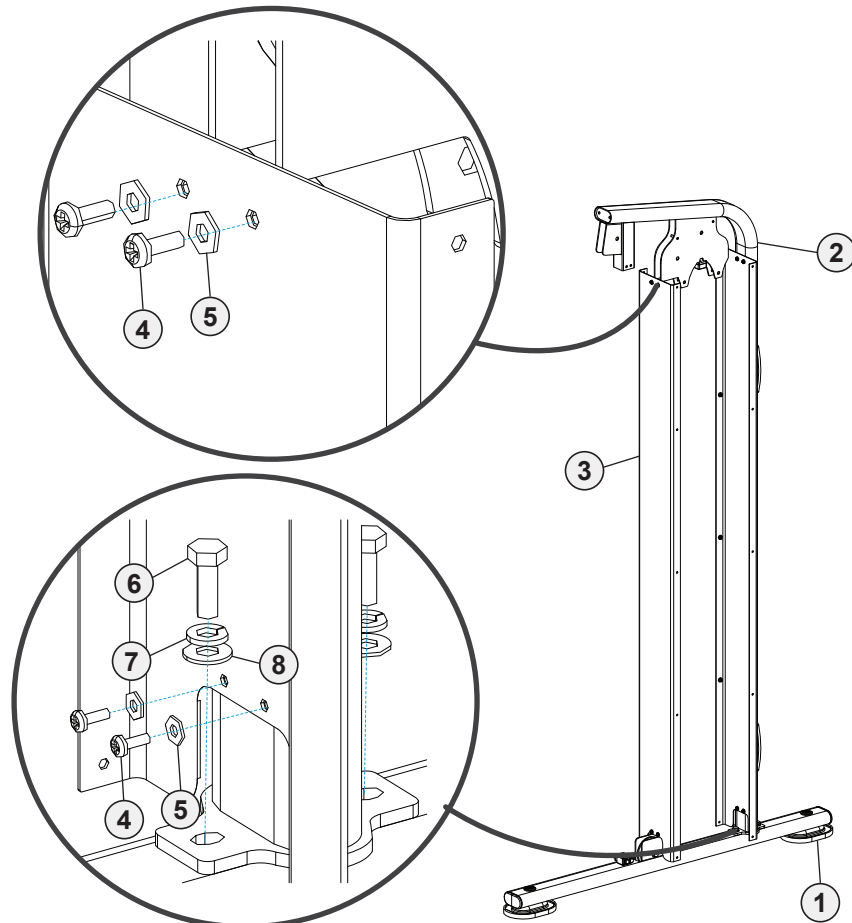

Step 2—Attach Adjustment Column

Tools Used in this Step	
7/16" Socket Wrench	
7/16" Wrench	
#2 Phillips Screwdriver	
9/16" Socket Wrench	

Parts Used in this Step			
Item	Part	Description	Qty
1	FS100-CLM001	CHROME ADJUSTMENT COLUMN	2
2	FS100-PH000X-35	PULLEY HOUSING ASSEMBLY, LEFT	1
3	FS100-PH100X-35	PULLEY HOUSING ASSEMBLY, RIGHT	1
4	C 416	HH SCREW, 1/4"-20, 2-1/4"	8
5	C 752	WASHER, FLAT, 1/4" SAE	16
6	C 740	LOCK NUT, 1/4"-20 NYL INS	8
7	FS100-STP001	STOP, COLUMN TRAVEL	4

A. Slide the left and right pulley housing onto the chrome adjustment columns in the correct orientation.

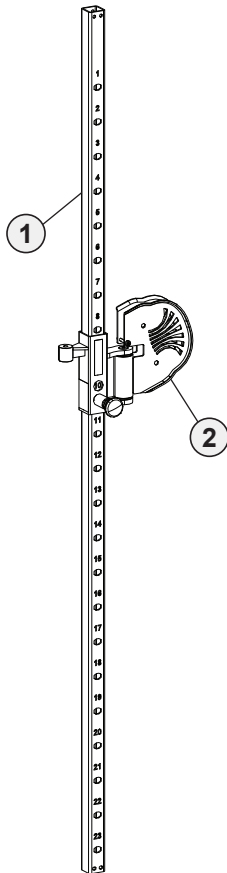

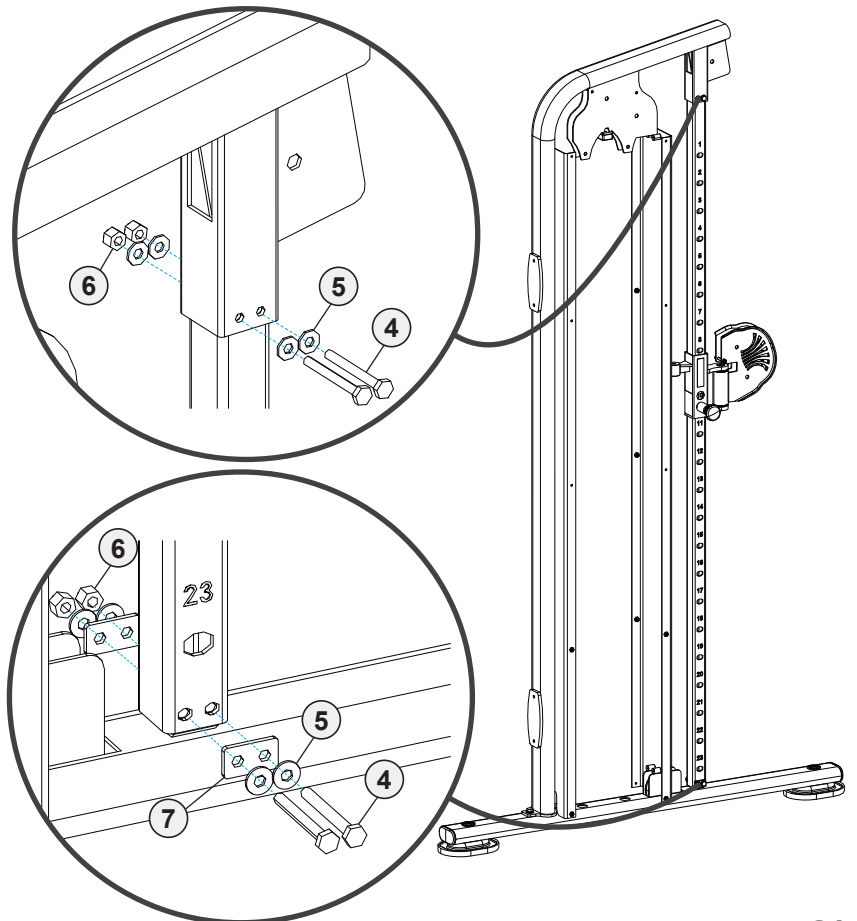

B. Insert the upper ends of the chrome adjustment columns into the frame tubes. Using a 7/16" socket wrench and open end wrench, attach the chrome adjustment columns using 8 bolts, 8 lock nuts, 4 stops, and 16 flat washers.

C. Fully tighten all hardware.



Step 3—Attach Cross Braces

Tools Used in this Step	
7/32" Allen Wrench	
9/16" Socket Wrench	

Parts Used in this Step			
Item	Part	Description	Qty
1	FS100-CBR000-35	WELDMENT, CROSS BRACE, LOWER	1
2	FS100-CBR100X-35	SUBASSEMBLY, CROSS BRACE, UPPER	1
3	FS100-CBR200	FS100 CHIN-UP BAR	1
4	FS100-LSF000X-35	ASSEMBLY, FRAME, LEFT SIDE	1
5	FS100-RSF000X-35	ASSEMBLY, FRAME, RIGHT SIDE	1
6	C 659ZP	FH SCREW, 3/8"-16, 1-1/4", ZP, LOCK PATCH	4
7	C 445	HH SCREW, 3/8"-16, 1"	8
8	C 749	WASHER, LOCK, 3/8", ZP	8
9	C 754C	WASHER, FLAT, 3/8" SAE, ZP	8

- A. Using a 9/16" socket wrench, attach the upper and lower cross braces to the frame assemblies using 8 bolts, 8 lock washers, and 8 flat washers, but do not tighten.



NOTE: The upper cross brace has accessory hooks on the front.

- B. Using a 7/32" allen wrench, attach the chin-up bar using 4 hex screws, but do not tighten.

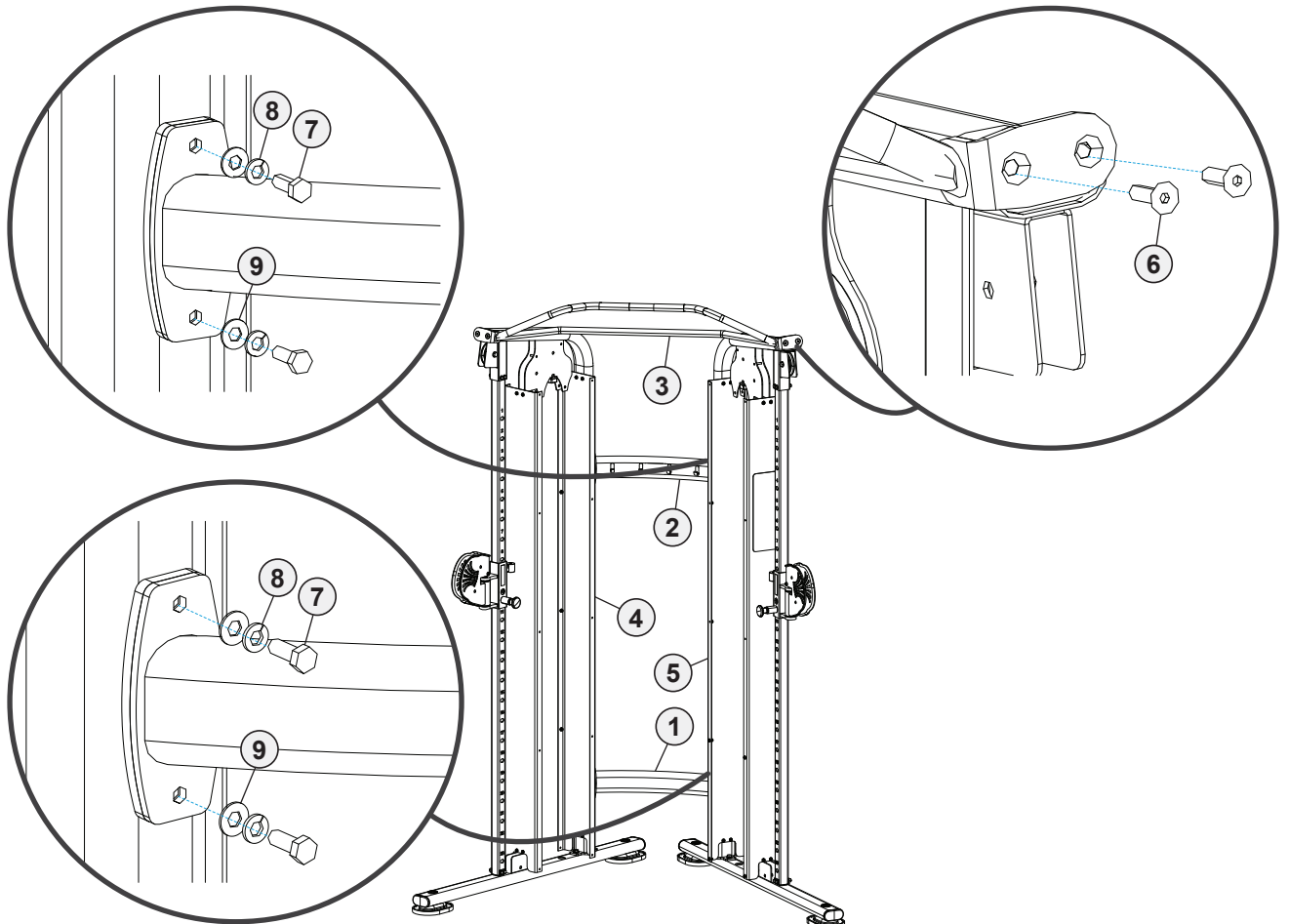
- C. Verify that all four feet of the machine are sitting on the floor. Incrementally tighten the hardware on the cross braces and chin-up bar. It may help to shake the machine as you tighten the hardware to help align the mating surfaces.

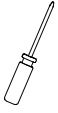

Step 4—Attach Rear Shroud Panels



Tools Used in this Step	
#2 Phillips Screwdriver	
3/8" Wrench	

Parts Used in this Step			
Item	Part	Description	Qty
1	FS100-RSH000XBK	SHROUD PANEL ASSEMBLY, REAR BLACK	2
2	FS100-SHD003-35	SHROUD BACKING PLATE	4
3	C 907	SCREW, 10-32 X 1/2", PAN HD. PHILLIPS, ZP	20
4	C 900A	WASHER, FLAT, #10 USS	32
5	C 900D	LOCK NUT, 10-32, NYL INS JAM NUT	12

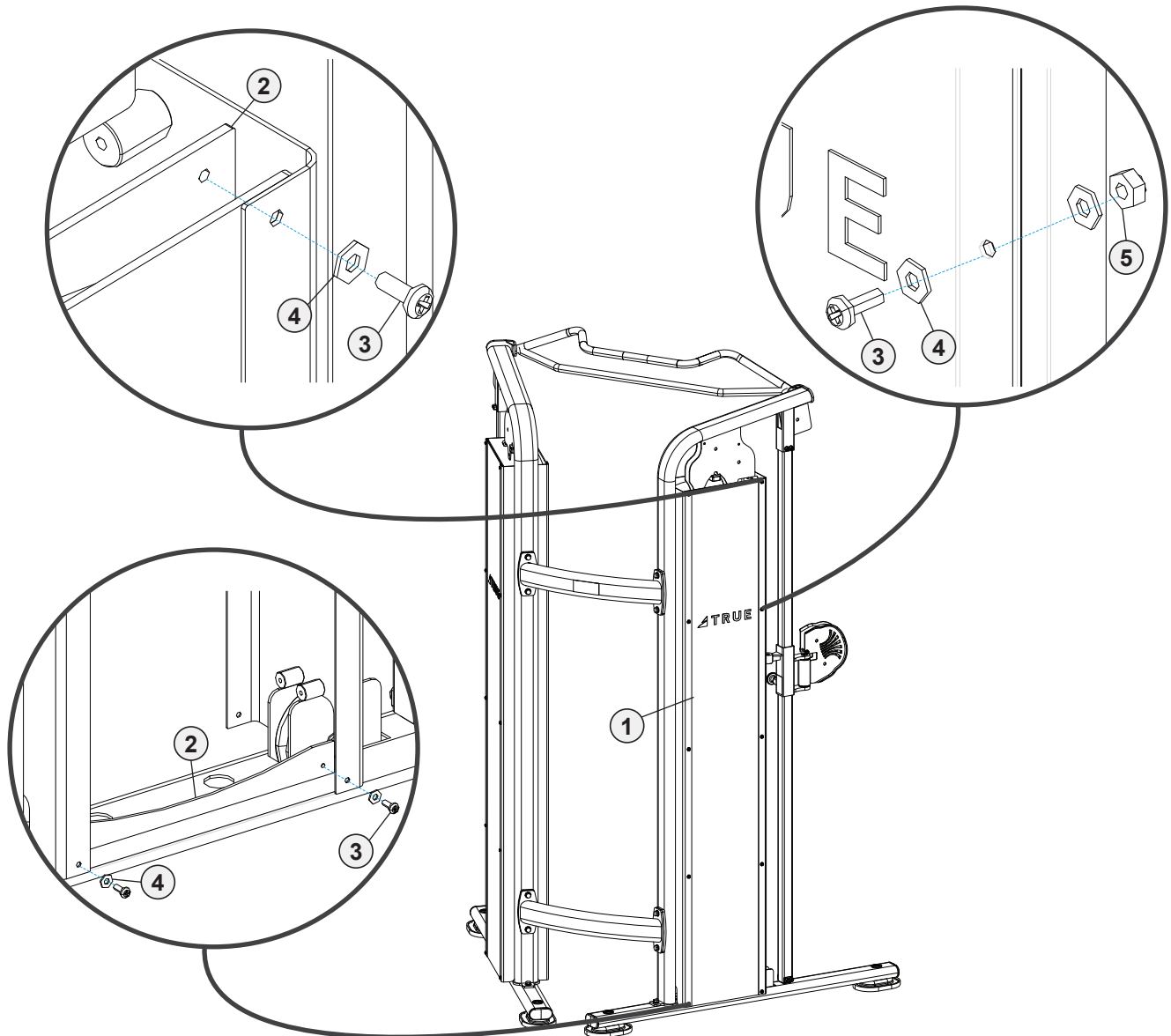
Using a #2 Phillips screwdriver and a 3/8" open end wrench, attach the rear shroud panels using 20 screws, 12 lock nuts, 32 flat washers, and 4 shroud backing plates.



Step 5—Attach Weight Plates

Tools Used in this Step	
Cloth	
Lubricant	

Parts Used in this Step			
Item	Part	Description	Qty
1	FS100-TPL000X-35	TOP PLATE & PULLEY HOUSING ASSEMBLY	2
2	FS100-GDR001	GUIDE ROD	4
3	XFT1002600	PULL PIN, GUIDE ROD RETAINER, 8MM X 52MM	4
4	RX-R-C-4005	BUMPER, 26MM ID X 25MM THICK	8
5	C 757	WASHER, FLAT, 1" USS	8
6	S 502	WEIGHT PLATE 10LB	24

- Remove the pull pins from the side frame and install the guide rods into the holes of the base frame.
- Wipe all dirt and dust from the guide rods before lightly applying a teflon (PTFE) spray lubricant. Spray the lubricant on a cloth or paper towel and use it to wipe down the guide rods.

IMPORTANT! DO NOT use oil lubricants such as WD-40.

IMPORTANT! Teflon (PTFE) lubricants will stain carpet or clothing.

- Tilt the guide rods forward and slide the washers, bumpers, weight plates, and top plate assembly down the guide rods.

IMPORTANT! DO NOT drop the weight plates when sliding onto guide rods.

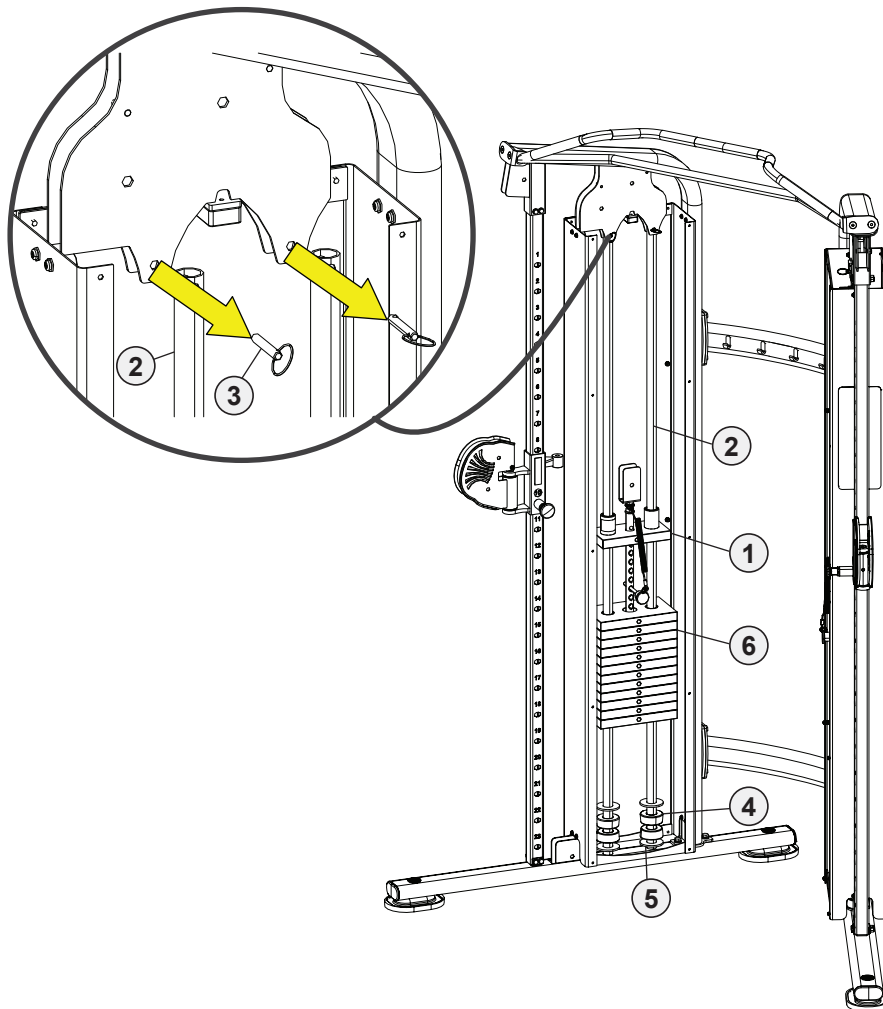

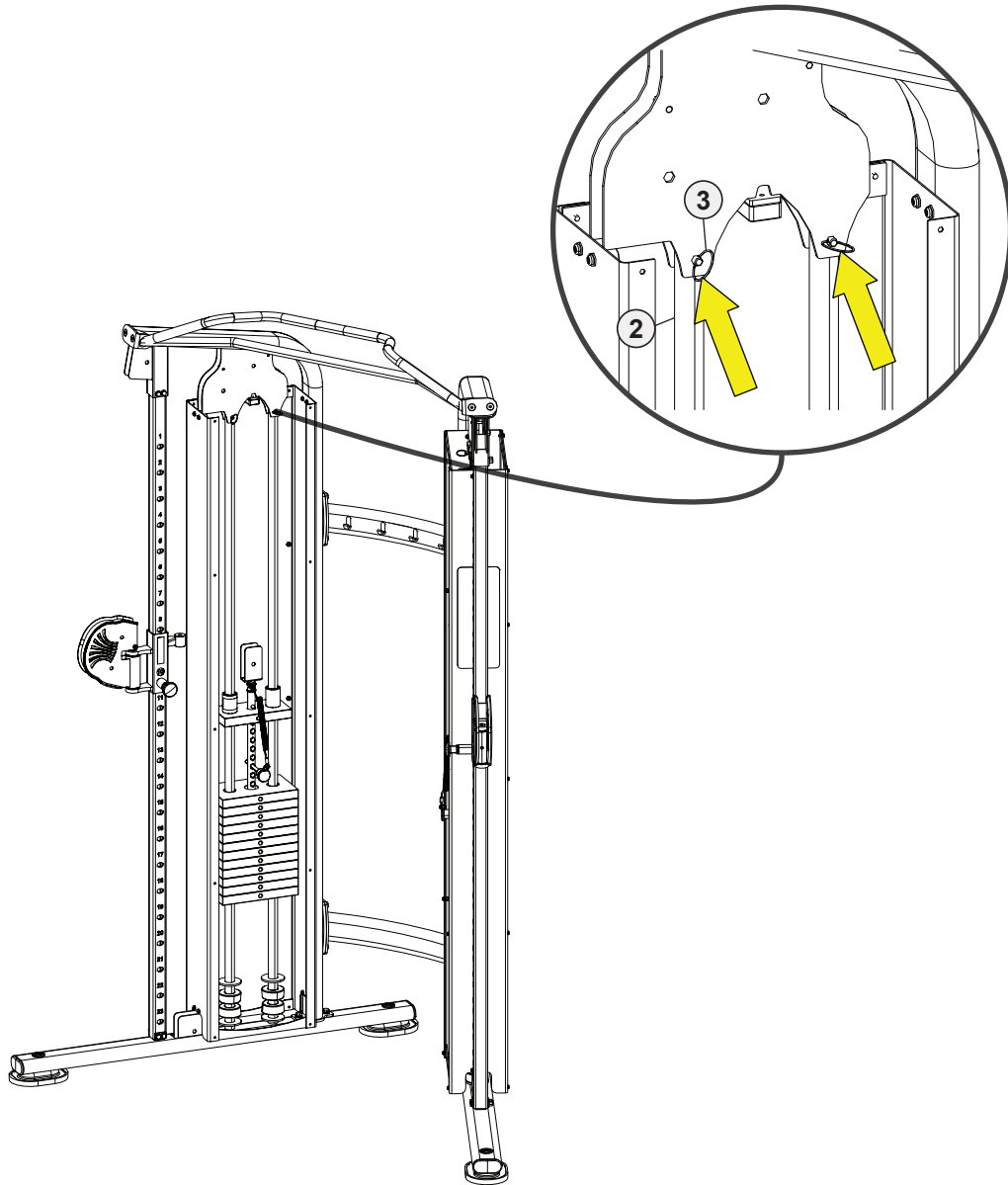

Step 5—Attach Weight Plates Continued

D. Slide the guide rods between the side frame and insert the pull pins.



Step 6—Attach Weight Stack Labels

Tools Used in this Step	
Cloth	
Isopropyl Alcohol	

Parts Used in this Step			
Item	Part	Description	Qty
1	LBL-WSEM-01065	WEIGHT STACK LABEL FS100	2
2	S 502	WEIGHT PLATE 10LB	24

- A. Wipe the front surface of the weights with isopropyl alcohol. Spray the isopropyl alcohol on a cloth or paper towel and use it to wipe down the front surface of the weights.

NOTE: Allow the weights to dry completely before proceeding.

NOTE: The weight stack labels contain both LB and KG designations for each plate.

NOTE: The designations on the label for each plate are the pull resistance at the handle and not the weight of the individual weight plates. See Dimensions and Weight for more information.

- B. The backing that covers the adhesive is cut in a series of vertical strips. If you just want to install the LB stickers, only remove the backing strip behind the area of the LB stickers. If you just want to install the KG stickers, remove the backing directly under the KG stickers.

IMPORTANT! DO NOT remove the backing from the area behind the center section with the holes.

- C. Carefully align the top hole in the label with the hole in the top weight plate. Align the bottom hole in the label with the hole in the bottom weight plate.
- D. Once the label is aligned, lightly press the individual stickers into place.



IMPORTANT! DO NOT rub the area surrounding the individual labels.

- E. Carefully press each sticker with your finger as you peel away the surrounding material.
- F. Once you are left with the individual stickers on each plate, press and rub the sticker firmly to the face of the plate.
- G. Allow the adhesive to cure for 48 hours.

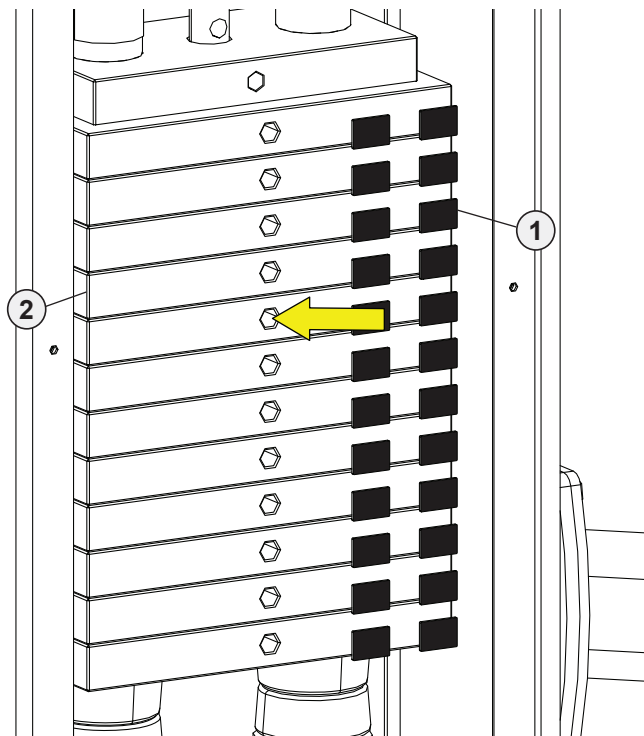
IMPORTANT! DO NOT test the integrity of the labels after they have been installed.



Step 7—Route Cables

Tools Used in this Step	
9/16" Socket Wrench	
9/16" Wrench	

Parts Used in this Step			
Item	Part	Description	Qty
1	FS100-CBL000X	CABLE ASSEMBLY	2
2	FS100-PH011-35	U-SHAPED PULLEY TRAVEL STOP	2
3	B 900A	4-1/2 PULLEY W/ 3/16 GROOVE	2
4	B 901	3-1/2 PULLEY W/ 3/16 GROOVE, 1"LG	12
5	C 448	HH SCREW, 3/8"-16, 1-3/4"	12
6	C 754C	WASHER, FLAT, 3/8" SAE, ZP	28
7	C 766A	LOCK NUT, 3/8"-16, NYL INS JAM NUT	14
8	C 453	HH SCREW, 3/8"-16, 2"	2
9	CB 500_INY	CABLE BOLT, 5/8-18 x 2"	2
10	C 733B	HEX NUT, 1/2"-13, SERRATED FLANGE	2
11	B1005	#2450-8 5/16" SNAP HOOK, ZINC	2
12	B1110ABK	FS100 HANDLE BLACK	2

NOTE: The cables on each side are routed from the pulley assembly to the chrome adjustment column.

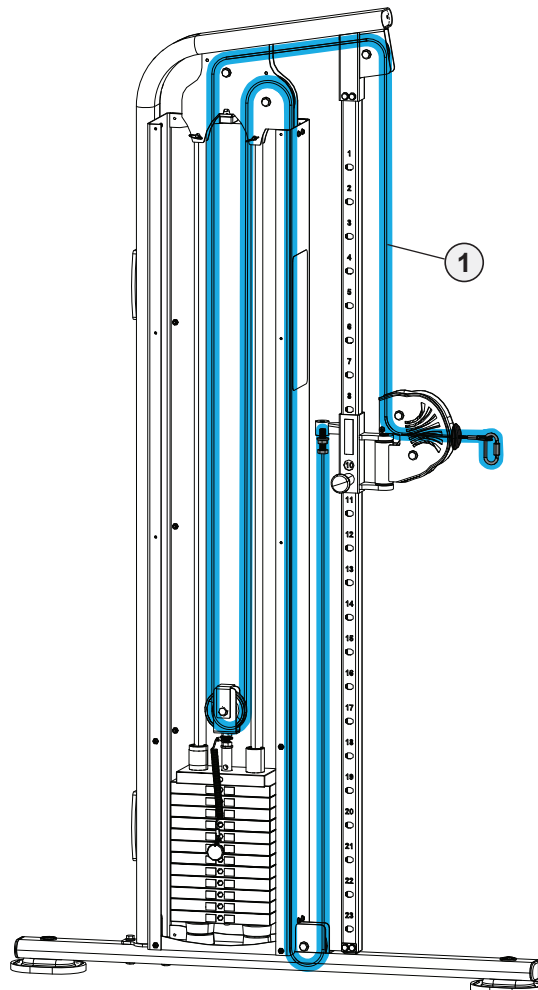

Step 7—Route Cables Continued

- A. Route the cable through the pulley assembly and around the pulleys.
- B. Using a 9/16" socket wrench and open end wrench, attach the pulleys using 4 bolts, 4 lock nuts, and 8 flat washers.

IMPORTANT! Ensure that the cable is not routed on the outside of the cable retainer pin.

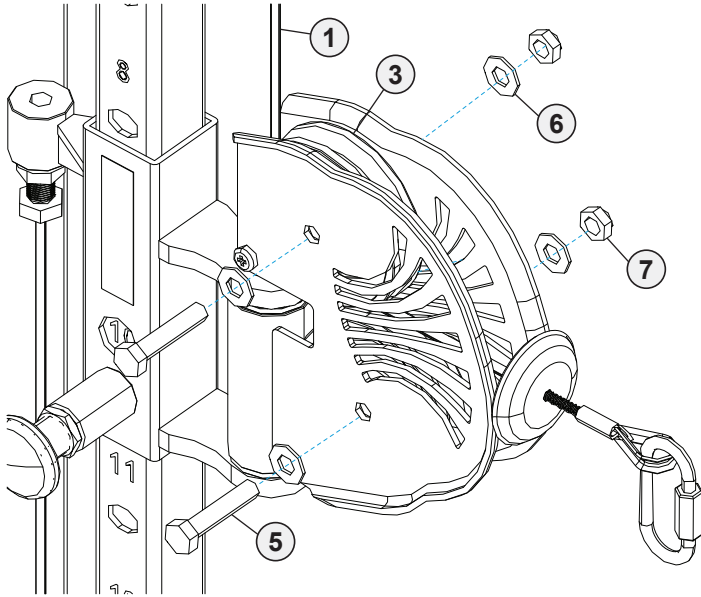

- C. Route the cable through the pulley assembly and around the pulleys.
- D. Using a 9/16" socket wrench and open end wrench, attach the pulleys using 2 bolts, 2 lock nuts, and 4 flat washers.

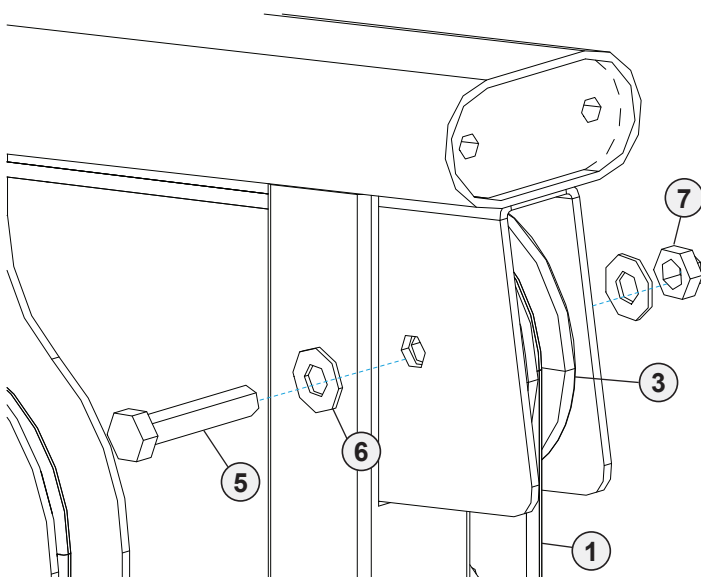

- E. Route the cable through the pulley assembly and around the pulleys.
- F. Using a 9/16" socket wrench and open end wrench, attach the pulleys using 4 bolts, 4 lock nuts, and 8 flat washers.

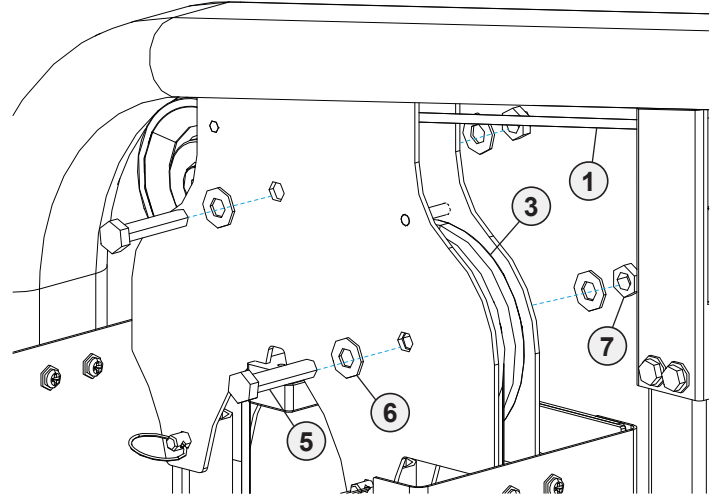

- G. Route the cable around the pulleys.
- H. Using a 9/16" socket wrench and open end wrench, attach the pulleys using 2 pulley travel stops, 2 bolts, 2 lock nuts, and 4 flat washers.

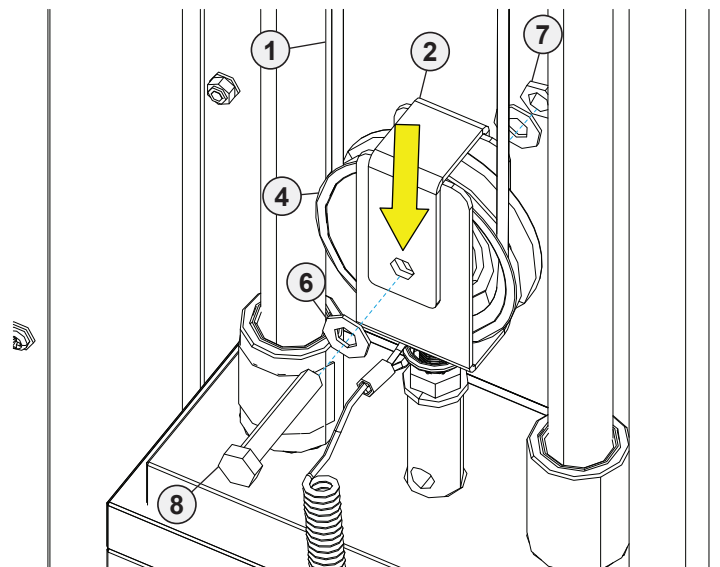

Step 7—Route Cables Continued

- I. Route the cable through the pulley assembly and around the pulleys.
- J. Using a 9/16" socket wrench and open end wrench, attach the pulleys using 2 bolts, 2 lock nuts, and 4 flat washers.

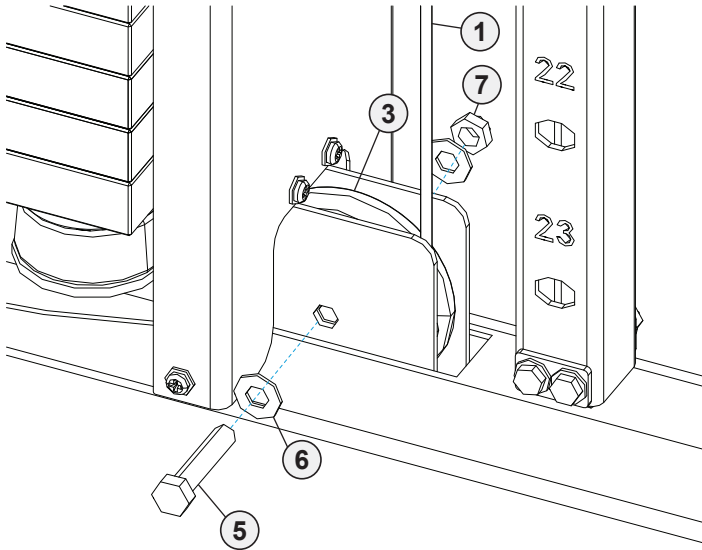

- K. Attach the cables to the cable attachment points using the cable bolts.

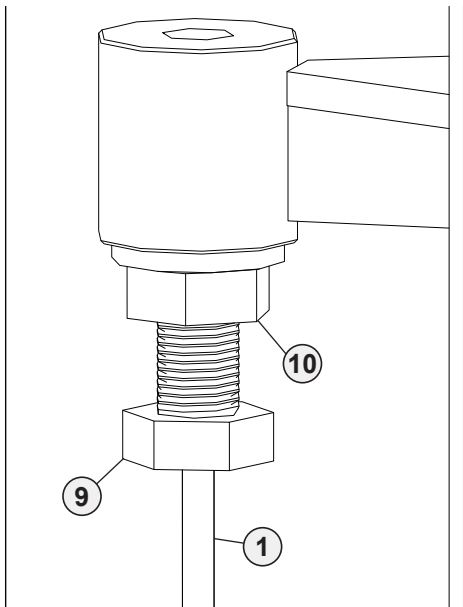

IMPORTANT! A minimum of 1/2" (12.7mm) of the threaded portion of the cable bolt must be threaded into the cable attachment point. Make sure locking nut is tight.

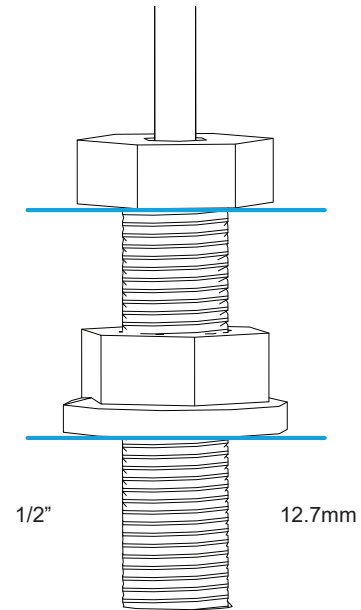

NOTE: Secure the cable bolt to the cable attachment point with the jam nut.

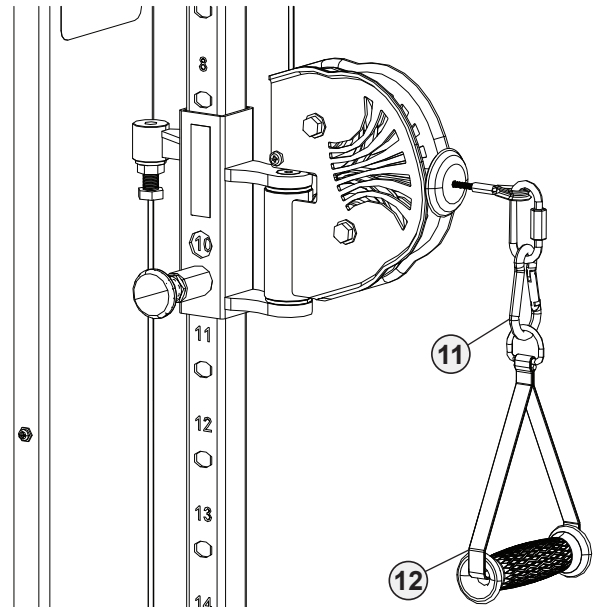

- L. Attach the snap hook and strap handle to the pulley assembly on each side.



Step 8—Attach Front Shroud Panels

Tools Used in this Step	
#2 Phillips Screwdriver	
3/8" Wrench	

Parts Used in this Step			
Item	Part	Description	Qty
1	FS100-FSRL0XBK	FRONT SHROUD ASSEMBLY, RIGHT SIDE FRAME, LEFT PANEL W/O LOGO BLACK	1
2	FS100-FSRR0XBK	FRONT SHROUD ASSEMBLY, RIGHT SIDE FRAME, RIGHT PANEL W/O LOGO BLACK	1
3	FS100-FSLL0XBK	FRONT SHROUD ASSEMBLY, LEFT SIDE FRAME, LEFT PANEL W/O LOGO BLACK	1
4	FS100-FSLR0XBK	FRONT SHROUD ASSEMBLY, LEFT SIDE FRAME, RIGHT PANEL W/O LOGO BLACK	1
5	FS100-SHD003-35	SHROUD BACKING PLATE	4
6	C 907	SCREW, 10-32 X 1/2", PAN HD. PHILLIPS, ZP	20
7	C 900A	WASHER, FLAT, #10 USS	32
8	C 900D	LOCK NUT, 10-32, NYL INS JAM NUT	12

Using a #2 Phillips screwdriver and a 3/8" open end wrench, attach the front shroud panels using 20 screws, 12 lock nuts, 32 flat washers, and 4 shroud backing plates.

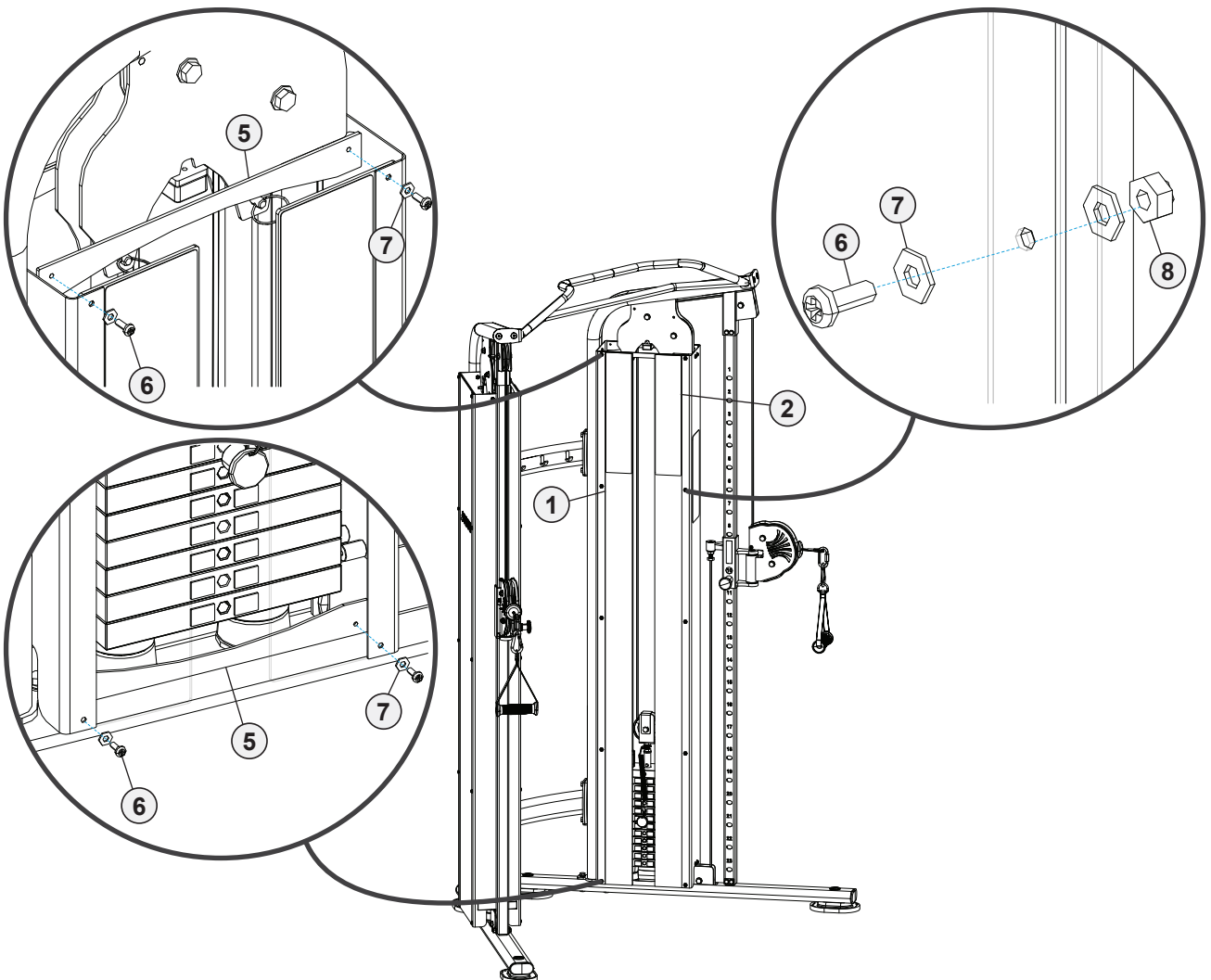

PREVENTATIVE MAINTENANCE

Preventative maintenance is crucial to maintaining the function and safety of this equipment. Your facility must establish written guidelines for preventative maintenance and keep written or online records of the maintenance performed on these products. As a minimum, the items presented in the Safety Instructions section of this document and the items that follow here, should be included in your maintenance program.

IMPORTANT! Always purchase replacement parts from TRUE. Many parts are tested and manufactured specifically for TRUE equipment. Use of unapproved parts may cause serious injury and/or void the limited warranty.

DAILY INSPECTION AND MAINTENANCE

The following items are critical to the safety of users and maintenance staff as well as ensuring the optimum performance of the machines. These inspections should be performed each day before the equipment is subject to use. TRUE is not responsible for performing or scheduling regular maintenance or inspections.

- Inspect cables for wear, tension, and proper connection if equipped. (See cable inspection and maintenance.)
- Inspect all adjustment pins, weight stack pins, set screws, gas shocks, snap links, and pulleys if equipped.
- Inspect all safety and instructional decals.
- Inspect all weight stack shields if equipped.
- Verify that rubber hand grips are intact and secure.
- Verify that anti-skid foot grips are intact and secure.
- Verify that the weight stack selector pin is attached with the coiled lanyard to the top plate if equipped. (See weight stack selector pin inspection.)

WEEKLY INSPECTION AND MAINTENANCE

The following items are critical to the safety of users and maintenance staff as well as ensuring the optimum performance of the machines. These inspections should be performed each week. TRUE is not responsible for performing or scheduling regular maintenance or inspections.

- Check entire length of cable and end fittings for any signs of wear if equipped. (See cable inspection and maintenance.) Replace immediately as required.
- Verify that a minimum of ½" (12.7mm) of the threaded portion of the cable bolt is threaded into the top plate and that the nut is tight if equipped with a cable. Make sure locking nut is tight. (See cable inspection and maintenance.)
- Perform a function test by placing the selector pin in the top plate and cycling the machine through the intended motion if equipped with a cable. Verify that the machine operates smoothly without binding. Select a moderate weight and repeat. (See weight stack selector pin inspection.)
- Verify that each pulley rotates freely when performing the exercise if equipped with pulleys. A pulley that does not rotate will cause extreme cable wear and could lead to cable failure. Determine cause and remedy immediately.
- Verify that the adjustment pop pins retract easily and fully engage (when released) into each adjustment disc hole/slot. The pop pins are spring loaded so they should return to the engaged position when you release the knob.
- Verify that the adjustment pin disengages and engages freely when actuating the adjustment mechanism. Be sure that the adjustment pin inserts fully into the adjustment disc.
- Verify that all hardware is tight and that associated frame members are secure. Apply a few small drops of a thread locking compound such as Loctite on any loose bolts.
- Inspect frame for integrity and function. Replace any components at the first sign of wear with only TRUE supplied parts.



OTHER SCHEDULED PREVENTATIVE MAINTENANCE

TRUE recommends that scheduled maintenance be performed by a qualified service technician. Please contact your dealer or visit www.truefitness.com to contact a local TRUE authorized service technician.

Monthly

Clean guide rods and lubricate with a Teflon grease if equipped with guide rods.

Every 6 Months

Lubricate pivot bearing and linear bearings with lithium grease.

CLEANING THE EQUIPMENT

Daily Cleaning

Wipe all machines with a water dampened cloth and dry completely. This includes painted parts, chrome plated parts (except guide rods), plastic parts, and upholstered pads. It is important not to leave parts damp. This will increase the potential for corrosion to occur.

▲CAUTION: Certain anti-bacterial cleaners and other harsh cleaning agents can induce corrosion on the machine components. These solutions can also dry out and cause cracking and splitting on the upholstery.

Heavy Duty Cleaning

- Guide Rods (if equipped)—Clean and lubricate with a Teflon Spray. Be sure to coat the entire guide rod. Spraying lubricant into the cap plate bushings is also recommended.
- Chromed Adjustment Tubes—Wipe away dust and dirt before applying a Teflon spray lubricant.
- Linear Bearings—Clean the linear shaft and lubricate (as required) with Teflon based grease. Keeping linear bearings clean and lubricated is critical to long life and good performance.
- Painted Frames—If you have scuff marks, grease or a heavy dirt buildup on frame components, start with a mild soap solution or a diluted solution of a product such as Simple Green with a dilution of 32:1. If you cannot remove the marks using those methods, use a car polish/cleaner. **DO NOT** use solvents such as lacquer thinner, mineral spirits or acetone. For deeper scuff marks, use an automobile finish rubbing compound.
- Upholstery—For heavy duty cleaning, use a mild soap solution. This method should be sufficient in the majority of instances. In severe stain cases, you can use a solution of 5-10% household bleach diluted with water. Be sure to test an inconspicuous area first. **DO NOT** use chemical cleaners on the vinyl upholstery. You can also use a lanolin based hand cleaner to clean your upholstery. Wipe off after cleaning with a damp cloth and thoroughly dry.
- Plastic Parts—Use a mild soap solution to clean dirt and grease marks.
- Labels—Use a mild soap solution to clean dirt and grease marks.
- Shrouds—Use a mild soap solution to clean dirt and grease marks.

▲CAUTION: Do not use any acidic cleaners. Doing so will weaken the paint or powder coatings and may void the TRUE Warranty. Never pour or spray liquids on any part of the equipment. Allow the equipment to dry completely before using.

▲CAUTION: If you determine that the equipment needs service, make sure that the equipment cannot be used inadvertently and ensure other users know that the machine needs service.

To order parts or to contact a TRUE authorized service representative, please visit www.truefitness.com.





CABLE INSPECTION AND MAINTENANCE

One of the most critical areas that require frequent inspection on any weight machine is the cable or belt system that lifts the weight stack if the machine is equipped with those items. Sudden failure of a worn cable can, in some instances, result in injury to the user. It is the responsibility of the facility to inspect the cables frequently. Cables are components that wear over time. This means that the more often a piece of equipment is used, the greater the likelihood that cable wear will occur. This holds true for equipment made by any manufacturer and applies to urethane belts as well as wire rope cables. Listed below are the areas of the cable that require inspection.

IMPORTANT! TRUE recommends that all cables be replaced on an annual basis to maintain the safety of all users.

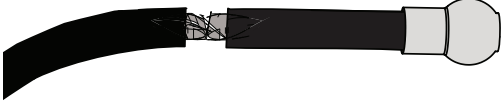
CABLE WEAR

Inspect all cables for any signs of wear. Pay close attention to the cable in the area of the end fittings and attachment points. Inspect the areas around the pulleys and/or cams. Shown below are examples of cables that exhibit signs of potential failure. If any of these conditions are apparent, the machine should immediately be taken out of service and repaired. Be sure to use only cables supplied by TRUE. **DO NOT** use cables that have fittings attached with hand-crimp tools.

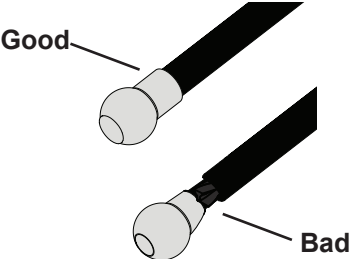
Examples of Cable Wear	
<p>Twisted Cable (Zig-Zag Pattern)</p> 	<p>Break in the Cable Cover</p> 
<p>Break or Bend in the Cable</p> 	<p>Tear in the Cable Cover</p> 
<p>Stretched Cable Covering</p> 	<p>Crimp Connector Dislodged</p> 

CABLE TENSION (IF APPLICABLE)

Ensure that the cables are adjusted to remove any slack using the threaded end fittings. These are normally located at the chrome adjustment columns. You can determine if there is too much slack by performing the exercise. As you start to move a load arm or handle, the weight stack should lift immediately. If not, the cable tension needs to be adjusted.

To adjust the cable tension, loosen the cable nut that is located on the cable bolt connected to the adjustment column. Tighten the cable bolt and then re-tighten the cable nut.

▲CAUTION: A minimum of $\frac{1}{2}$ " (12.7mm) of the threaded portion of the cable bolt must be threaded into the cable attachment point. Maximum height from bottom of nut to bolt head is $1\frac{1}{4}$ " (31.75mm). Make sure locking nut is tight.

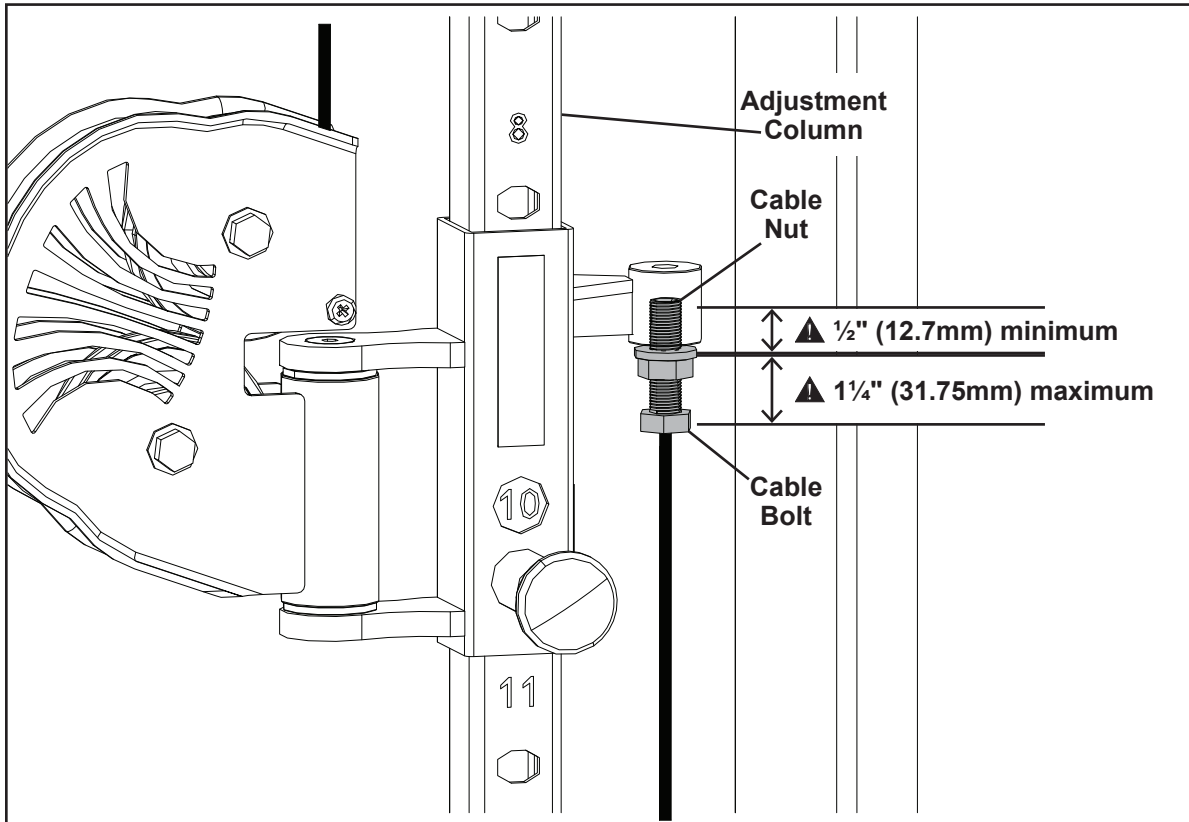

HANDLE FITTINGS (IF APPLICABLE)

Inspect the cable and fittings where handles are attached to the end of the cable. The fittings originally supplied with your machine are load rated snap-links and quick-links. Be sure the hex nut on the quick link is fully tightened. Be sure that the snap-link opens and closes easily and is fully engaged when closed. Replace if either are damaged.

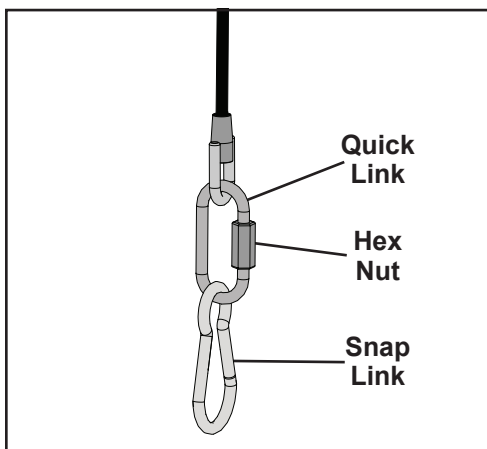

CABLE FITTING ATTACHMENTS (IF APPLICABLE)

Depending upon the machine, cable end fittings can either be securely fixed, rotate about a single axis, or can be free floating. On machines where the cable fitting is designed to rotate about a single axis, verify that the fitting rotates freely and that the hardware used to secure the cable pivot axle (most likely a pin or a bolt) is correctly fastened.

⚠CAUTION: When tightening hardware for cable fittings that are designed to rotate, make sure not to overtighten as to cause the cable fitting to bind. An occasional application of synthetic grease can be applied to the cable fitting pivot axle.

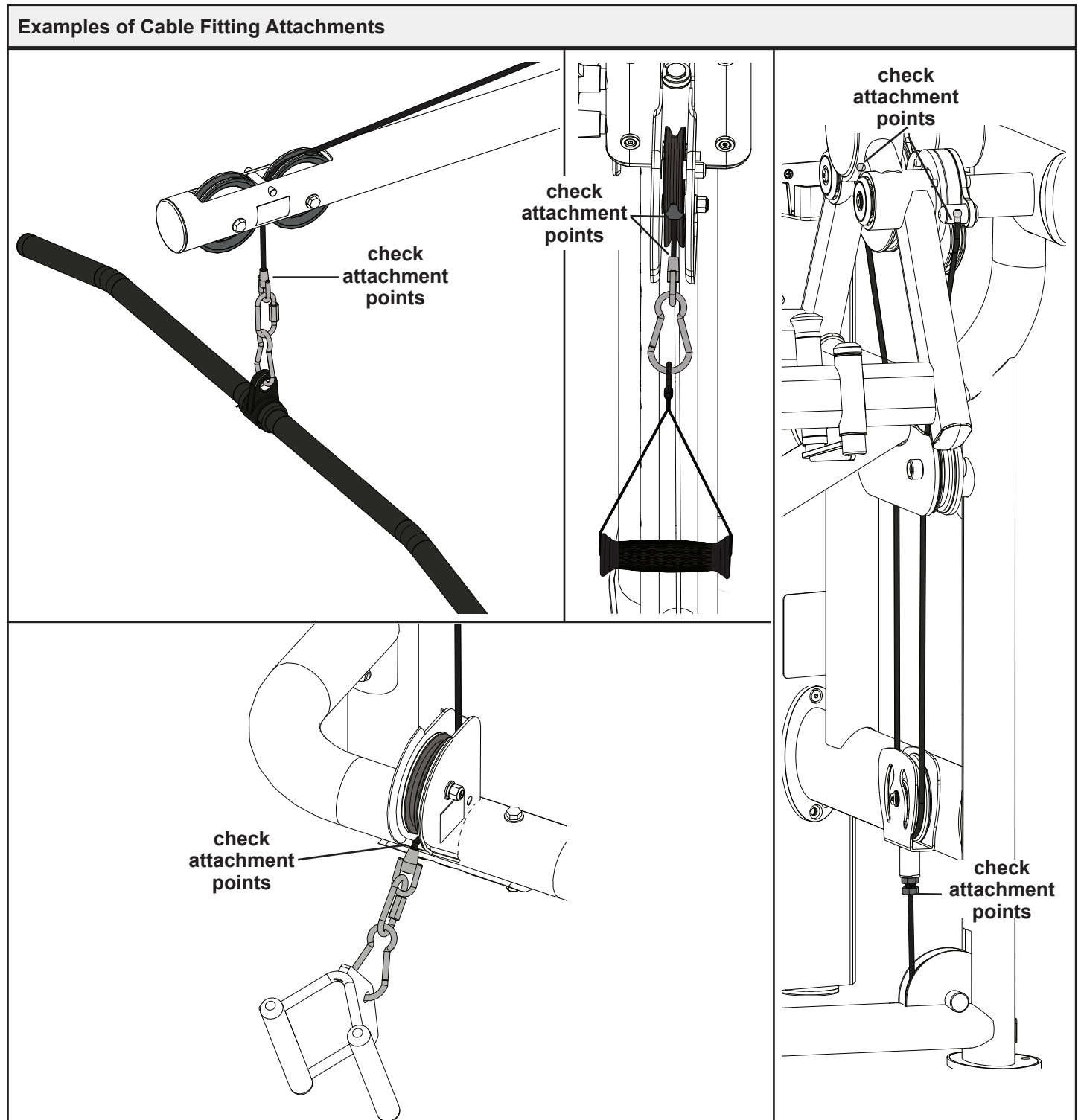

WEIGHT STACK SELECTOR PIN INSPECTION

Verify that the weight stack selector pin is attached with the coiled lanyard to the top plate (if equipped). Verify the selector pin slides in and out of each weight plate. Place the selector pin in the top plate. Cycle the machine through the intended motion. Verify that the machine operates smoothly without binding.

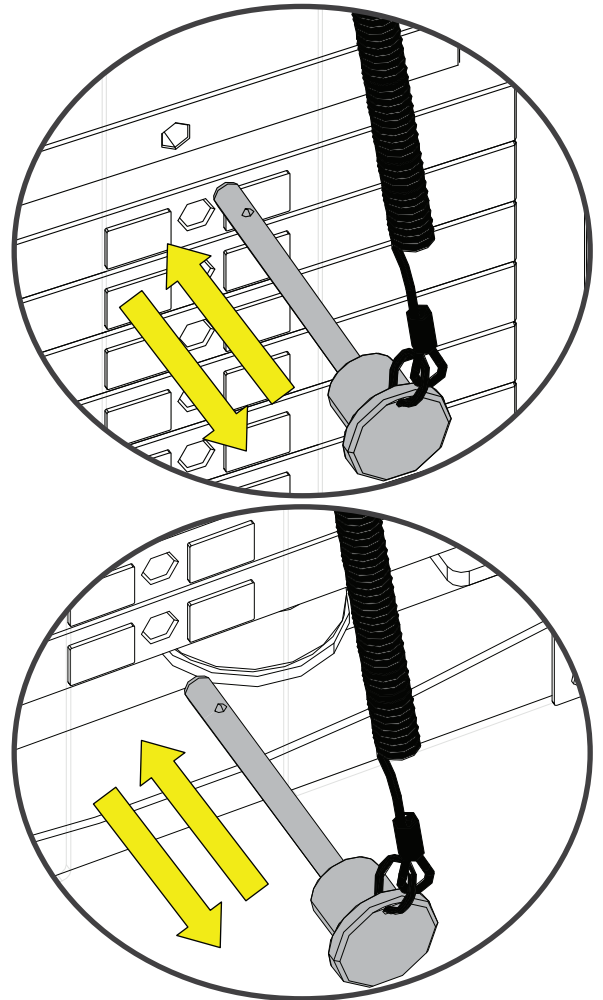
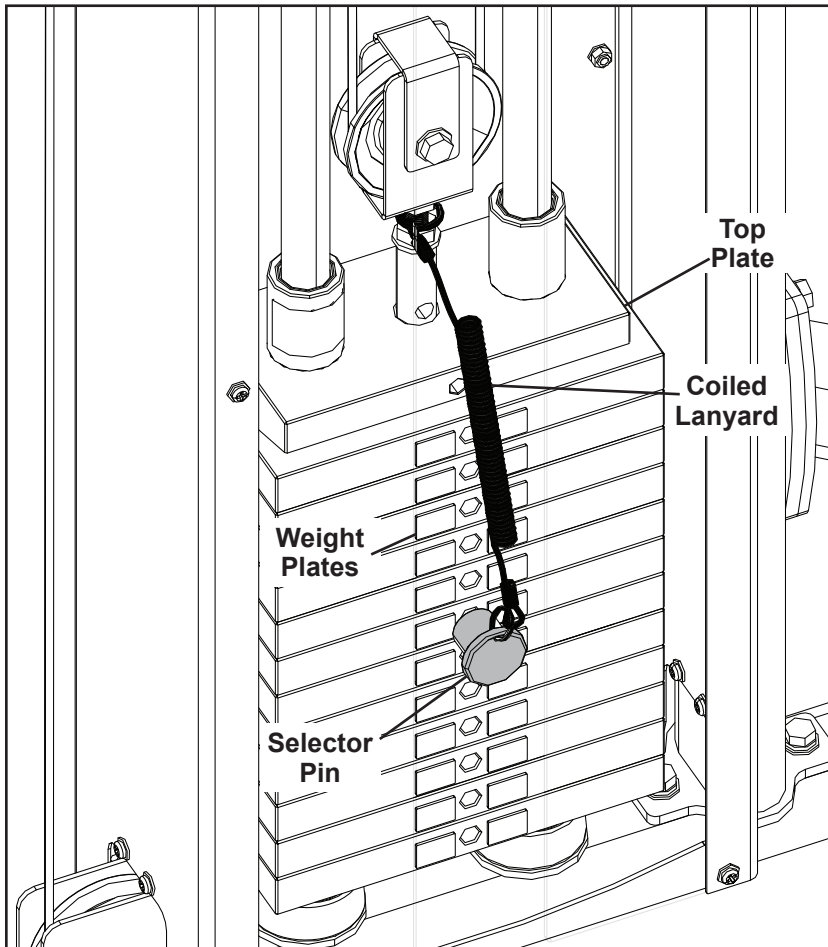

WARRANTY INFORMATION

FS-100-35 LIMITED WARRANTY

SAVE TIME AND REGISTER ONLINE!

<https://truefitness.com/support/warranty-registration/>

All TRUE® Fitness products are distributed by TRUE and are warranted to the original registered product purchaser and the parts of the TRUE product (the “Product”) listed below, under normal use and service, shall be free of manufacturing defects in workmanship and materials only for the period of time beginning from the original date of purchase set forth below.

WARRANTY ITEM	DURATION
Frame* Frame components and welds excluding coatings	10 Years
Parts Bushings, sealed rotating bearings, pulleys, weight plates and guide rods excluding coatings	5 Years
Cables, linear bearings and shafts and all other components not mentioned elsewhere in this warranty	1 Year
Wear items; normal wear parts including but not limited to labels, upholstered pads, and grips	90 Days
Labor Frame	1 Year
Parts	1 Year
Wear Items	90 Days

NOTES:

- Warranty valid for USA and Canada only.
- Failure to register this product will result in no servicing or authorization of parts to be shipped.
- Buying after-market products from a 3rd party will result in voided warranty.
- This product is intended for commercial use which includes non-dues paying facilities where usage exceeds 8 hours per day. If this product will not be used in this particular setting, please contact TRUE as this warranty is void.

DO NOT RETURN TO THE RETAILER

TRUE limited warranty service may be obtained by contacting the authorized TRUE dealer from whom the Product was purchased. If the dealer from whom the Product was purchased, is no longer an authorized TRUE dealer, TRUE limited warranty may be obtained by contacting TRUE Product Support:

- service@truefitness.com
- 800.883.8783

Monday - Friday 8:30am - 5:00pm (CST)

FRAME

*This limited warranty on the structural frame does not include paint or coatings. The frame is defined as the serialized base of the unit and does not include any parts that can be removed. Warranty applies to the value of the frame only and does not cover labor, shipping, or other costs associated with removal or replacement of the covered unit. Frame warranty shall not exceed seven years after discontinuation of this specific model.

PARTS

The parts are warranted for defects in material and workmanship for five years with one year labor warranty. Cables, linear bearings and shafts, and all other components not mentioned elsewhere in this warranty have one year parts warranty and one year labor warranty. This limited warranty does not cover damage or equipment failure resulting from or caused by improper assembly/installation, failure to follow instructions and warnings in the owner’s manual, accident, misuse, abuse, unauthorized modification, or failure to provide reasonable and necessary maintenance.

WEAR ITEMS

The cosmetic parts, coatings, grips and upholstery are warranted for defects in material and workmanship for 90 days with labor warranty to match the parts warranty period. This limited warranty does not cover damage or equipment failure resulting from or caused by improper assembly/installation, failure to follow instructions and warnings in the owner’s manual, accident, misuse, abuse, unauthorized modification, or failure to provide reasonable and necessary maintenance. This limited warranty will apply to, but may not be limited to, plastic covers, shrouds, caps, badges, overlays, paint, coatings, labels, upholstered pads, and grips.

LABOR

Labor is covered for the specified period of time from the date of purchase, unless otherwise expressed within this limited warranty as long as a TRUE authorized service provider performs the service. Service that requires over 50 miles of travel may be subject to additional charges.

REASONABLE AND NECESSARY MAINTENANCE

Failure to perform proper maintenance as specified in the owner’s manual will void this limited warranty. Proof/ receipts of necessary maintenance may be required within 30 days of requested warranty part or service.



SAVE TIME AND REGISTER ONLINE!

<https://truefitness.com/support/warranty-registration/>

THE TRUE LIMITED WARRANTY IS SUBJECT TO AND WILL BE IN ACCORDANCE WITH THE CONDITIONS SET FORTH BELOW:

1. This limited warranty is valid for the United States and Canada only.
2. This product is intended for specified use. If this product will not be used in the specified setting, please contact TRUE as this warranty is void, unless otherwise stated and within this warranty.
3. This limited warranty gives you specific legal rights, and your rights may vary from state to state.
4. This limited warranty is in lieu of all other warranties of any kind either expressed or including but not limited to implied warranties of merchant.
5. This limited warranty can be processed only if the warranty registration form is completed on-line; or if the attached form is filled in, signed by the original purchaser, and mailed to TRUE within 30 days of purchaser's receipt of this Product. The serial number must be intact on the Product for this limited warranty to be valid.
6. TRUE will neither assume nor authorize any person to assure for us any other obligation or liability concerning the sale of this Product. Under no circumstances shall TRUE be liable under this warranty, or otherwise, of any damage to any person or property, including any lost profits or lost savings, for any special, indirect, secondary, incidental, or consequential damages arising out of the use of or inability to use this Product.
7. Failure to register this product within 30 days of purchase will result in no servicing or authorization of parts to be shipped.
8. Installation or download of any 3rd party or after-market products will result in voided warranty. Includes but not limited to electrical and mechanical parts, software, or applications.
9. TRUE will ship to any authorized service provider any new or rebuilt replacement part or component, or at our option, replace or refund the Product. Replacement parts are warranted for the remaining portion of the original warranty period.
10. No one is authorized to change, modify, or extend the terms of this limited warranty.
11. This limited warranty applies to the Product only while the Product remains in the possession of the original purchaser and is not transferable.
12. This limited warranty becomes VALID ONLY if the Product is initially assembled/installed by a TRUE authorized dealer/technician (if anyone other than a TRUE authorized dealer/technician initially assembles and installs the Product, this limited warranty will be void unless the written authorization of TRUE is first obtained).
13. This limited warranty does not cover damage or equipment failure resulting from or caused by improper assembly/ installation, failure to follow instructions and warnings in owner's manual, accident, misuse, abuse, unauthorized modification, or failure to provide reasonable and necessary maintenance (as referenced in the owner's manual). Proof/receipts of necessary maintenance may be required within 30 days of requested warranty part or service.
14. This limited warranty applies only to the cost of repair or replacement of parts and does not include labor (beyond the above warranty period), transportation, service, return, and freight charges associated there with except as expressly specified herein.
15. This limited warranty shall not apply to: Service calls to correct installation of the equipment or instruction to owners on how to use the equipment; or any labor costs incurred beyond the applicable labor warranty period.
16. This limited warranty, which is given expressly and in lieu of all other express warranties, constitutes the only warranty made by TRUE.
17. **ANY IMPLIED WARRANTY, INCLUDING WITHOUT LIMITATION THE WARRANTIES OF MERCHANTABILITY AND FITNESS FOR A PARTICULAR PURPOSE, IS LIMITED IN DURATION AND REMEDY TO THE TIME PERIOD COVERED BY THE LIMITED WARRANTY. SOME STATES DO NOT ALLOW LIMITATIONS ON HOW LONG AN IMPLIED WARRANTY LASTS, SO THE ABOVE LIMITATION MAY NOT APPLY TO YOU.**
18. **THE REMEDIES DESCRIBED HEREIN ARE YOUR SOLE AND EXCLUSIVE REMEDIES AND TRUE'S ENTIRE LIABILITY FOR ANY BREACH OF THIS LIMITED WARRANTY. TRUE'S LIABILITY SHALL UNDER NO CIRCUMSTANCES EXCEED THE ACTUAL AMOUNT PAID BY YOU FOR THE PRODUCT, NOR SHALL TRUE UNDER ANY CIRCUMSTANCES BE LIABLE FOR ANY CONSEQUENTIAL, INCIDENTAL, SPECIAL OR PUNITIVE DAMAGES OR LOSSES, WHETHER DIRECT OR INDIRECT. SOME STATES DO NOT ALLOW THE EXCLUSION OR LIMITATION OF INCIDENTAL OR CONSEQUENTIAL DAMAGES, SO THE ABOVE LIMITATION OR EXCLUSION MAY NOT APPLY TO YOU.**

NOTE TO AUTHORIZED WARRANTY LABOR PROVIDERS—Warranty labor reimbursement or warranty parts rights may not be transferred to, or reassigned to, a third party without the express written consent of TRUE. Even jobbing out warranty labor requires TRUE's written approval.

SAVE TIME AND REGISTER ONLINE!
<https://truefitness.com/support/warranty-registration/>

STRENGTH SERIAL NUMBER:

This machine comes with one serial number on the base of the machine. Please write down your serial number below and keep for your records.

PLEASE KEEP THIS FOR YOUR RECORDS

RETAIN THIS PORTION
 BASE SERIAL NUMBER:



Thank you for purchasing a TRUE product. To validate the TRUE product warranty the fast and easy way, please go on-line now to truefitness.com and register your product. The information you provide will never be distributed to any other individuals or agencies for any purpose. If you prefer to mail your warranty card, have the owner of the product complete the information below and return it to TRUE Fitness within 30 days from the date of equipment installation.

IMPORTANT! Failure to register this product will result in no servicing or authorization of parts to be shipped.

To mail your warranty information, please fill in the information below and mail to: Service Dept., TRUE Fitness, 865 Hoff Road, St. Louis, MO 63366 (or save postage and register online at www.truefitness.com).



Warranty Registration

Base Serial Number

Purchase Date

Company (if applicable)

Customer Name (First and Last)

Email Address

Phone Number

Street Address

City

State

Postal Code

Country



CONTACT US

service@truefitness.com

1.800.883.8783

865 Hoff Road
St. Louis, MO 63366

[TRUEFITNESS.COM](https://www.truefitness.com)

